



ISO Registered Company



MODEL 345

## MODEL 345

### HIGH PRESSURE REDUCING REGULATOR

The Model 345 is a piston style, heavy duty, high pressure reducing regulator that can include balanced trim with a TFE or nylon seat for controlling downstream pressure between 50 and 3000 psig (3.4 and 207 Barg), with inlet pressures up to 4000 psig (275 Barg). The metal seated version is an unbalanced trim design. Where trim wear is expected, metal seating surfaces may be stellite. Sizes 1/2", 3/4" and 1" (DN15, 20, and 25). Available options include flanged end connections.

#### FEATURES

- High Pressure:** High inlet and outlet pressures; high pressure drops.
- Balanced Trim:** Minimizes the effect of large changes in inlet pressure such as those encountered with bottled gas.
- Tight Shutoff:** TFE or nylon seat provides tight shutoff.
- Adjustment Ease:** Radial roller bearings to reduce frictional forces and wear. Standard T-bar handle.

#### APPLICATIONS

Primarily used as first stage letdown valve on high pressure applications.

Used for controlling clean gases. Handles bottled gas up to 4000 psig (275 Barg) inlet pressure, with a maximum pressure drop of up to 3000 psid (207 Bard).

Use in liquid service is for non-cavitating fluids, i.e. lubricants, up to 1000 psid (69.0 Bard) pressure drop, metal seated.



**CAUTION**

**DO NOT APPLY IN STEAM SERVICE.**

## STANDARD/GENERAL SPECIFICATIONS

**Body Sizes:** 1/2", 3/4", 1"  
(DN15, 20, and 25).

**Maximum Pressure Drop:** See Table 2.

**End Connections:** Standard: NPT female.  
Opt-30: 300#, 600#, 900# or 1500#  
RF flanges with SST body.  
Opt-34: 14" Face to Face Flange  
Dim.

**Trim Designs:** Primarily 316 SST material.  
Metal Seat - Unbalanced.  
Composition Seat - Balanced. See  
Table 4.

**Body Materials:** AL BRZ = Aluminum Bronze  
ASTM B148, Alloy C95500.  
SST = Cast Stainless Steel  
ASTM A351, Gr. CF8M.

**Capacities:** See Tables 6 through 9.  
Recommended practical limit of 20%  
droop.  
See Table 5 for maximum wide open  
 $C_v$  level.

**Spring Chamber Material:** BRZ = Cast Bronze  
ASTM B584, Alloy C90300.

**Range Springs:** Epoxy coated steel.

**Inlet Pressure:** Up to 4000 psig (275 Barg).

**Inlet Temperature:** Function of trim materials.  
Up to 400°F (205°C), S1 trim only.  
(See Table 4.)

Applicable Seat Design	Range	
	psig	(Barg)
Balanced - Comp *	50 - 150	(3.4 - 10.3)
Balanced - Comp *	125 - 250	(8.6 - 17.2)
All	200 - 600	(13.8 - 41.4)
All	500 - 1000	(34.5 - 69.0)
All	900 - 3000	(62.1 - 207)

\* See Table 6.

**Outlet Pressure:** 50 to 3000 psig (3.4 to 206 Barg) with  
multiple range springs.

**Pressure vs. Temperature Ratings:** May be reduced when available  
flanged end connections are selected.  
See Table 1 and Table 10.

**Gaskets:** Standard: Graphite/NBR. NOT SUIT-  
ABLE FOR OXYGEN SERVICE.

Alternate Material: See Opt-45.

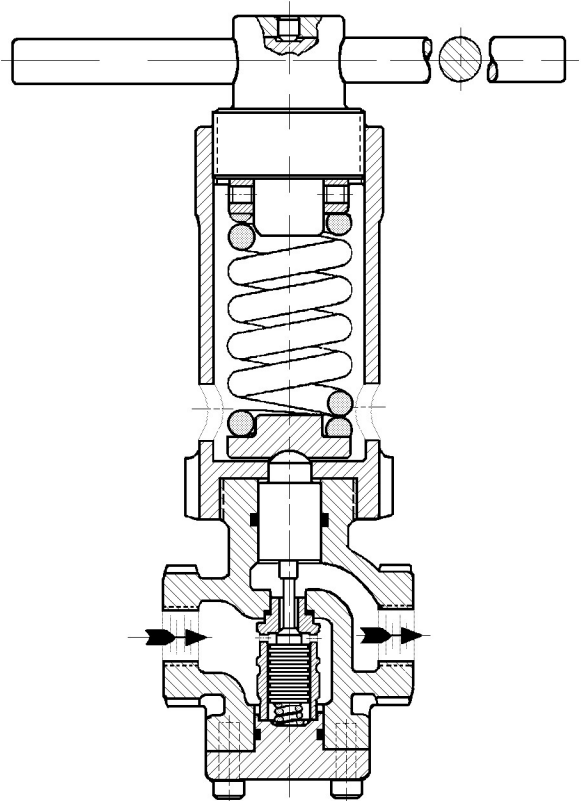

**Figure 1:** Metal Seat,  
Unbalanced Trim Design

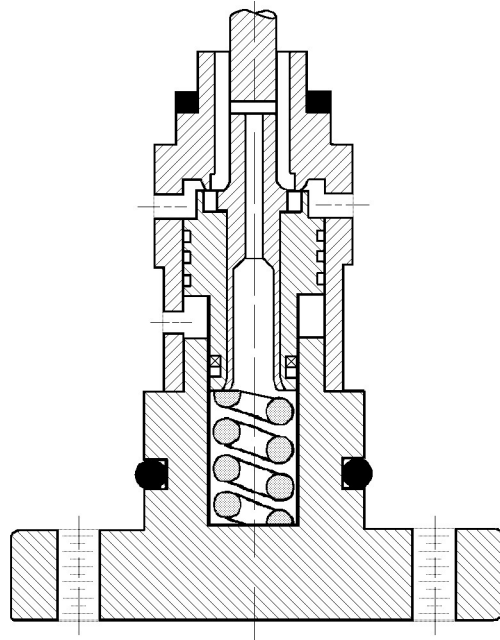

**Figure 2:** Composition Seat,  
Balanced Trim Design

## OPTION SPECIFICATIONS

This section indicates special variations which are available to the standard Model 345 product. Multiple options may be selected; i.e. 345-15 +30 which is the standard 345 product plus the -15 and the -30 Options together. Care must be exhibited to not develop conflicting combinations; i.e. an aluminum bronze body 345-30.

- |                                                                                                                                                                                                                                                                                                                                                                                               |                                                                                                                                                                                                                                                                               |
|-----------------------------------------------------------------------------------------------------------------------------------------------------------------------------------------------------------------------------------------------------------------------------------------------------------------------------------------------------------------------------------------------|-------------------------------------------------------------------------------------------------------------------------------------------------------------------------------------------------------------------------------------------------------------------------------|
| <p><b>Option -15:</b>     <u>STELLITED SEATS.</u> Stellite seating surfaces on unbalanced metal seating piston and cylinder. Can only be applied to S1 trim.</p>                                                                                                                                                                                                                              | <p><b>Option -55:</b>     <u>SPECIAL CLEANING.</u> SST body material ONLY. Cleaning per Cashco Spec #S-1134 for Oxygen gas Service.<br/><b>NOTE:</b> Design Pressure Rating shall not exceed 375 psig (25.8 Barg) when body material is SST and process medium is oxygen.</p> |
| <p><b>Option -30:</b>     <u>FLANGED END CONNECTIONS.</u> 300#, 600#, 900#, and 1500# raised face flanges available for 316 SST body. Flanges and nipples of same basic material as body.<br/><br/>With all flanges, the flange pressure ratings are the pressure limiting factors, not the body inlet rating. (Refer to Table 10 for allowable working pressure vs. temperature tables.)</p> | <p><b>Option -56:</b>     <u>SPECIAL CLEANING.</u> Cleaning per Cashco Spec. #S-1542. Not suitable for Oxygen Service.</p>                                                                                                                                                    |
| <p><b>Option -34:</b>     <u>SPECIAL 14" FACE TO FACE DIMENSION FOR FLANGED END CONNECTIONS.</u> See Opt.-30 for standard face to face dimension.</p>                                                                                                                                                                                                                                         |                                                                                                                                                                                                                                                                               |
| <p><b>Option -45:</b>     <u>FKM GASKET.</u> Primarily for oxygen service. Utilizes FKM gasket over standard gasket. (S3S Trim has gylon gasket.)</p>                                                                                                                                                                                                                                         |                                                                                                                                                                                                                                                                               |

## TECHNICAL SPECIFICATIONS

**TABLE 1  
DESIGN PRESSURE –TEMPERATURE RATINGS  
MATERIAL SPECIFICATIONS**

Standard Construction							
Material Specifications (Body / Spring Chamber)		Inlet Pressure		Outlet <sup>1</sup> Pressure		Temperature †	
Material	ASTM No.	psig	(Barg)	psig	(Barg)	°F	(°C)
AL BRZ/BRZ	B148, C95500/ B584, C90300	4000	(275)	3000	(207)	-20 to +100	(-29 to +38)
		3200	(221)	2700	(186)	+200	(+93)
		2700	(186)	2500	(172)	+300	(+149)
		2500	(172)	2500	(172)	+400	(+205)
SST/BRZ	A351, Gr CF8M B584, C90300	3600	(248)	3000	(207)	-20 to +100	(-29 to +38)
		3100	(214)	2800	(193)	+200	(+93)
		2800	(193)	2500	(172)	+300	(+149)
		2500	(172)	2500	(172)	+400	(+205)

<sup>1</sup> See Table 5 for emergency over-pressures allowed for sizing and selection of safety relief valve.  
<sup>†</sup> The design temperature range of the regulator may be limited by the trim selection. See Table 4.

**TABLE 2  
MAXIMUM ALLOWABLE PRESSURE DROPS**

Fluid	Maximum Recommended Operating Pressure Drop				Seat Design	Trim Designation Number
	Clean Fluid Industrial Quality		Unclean Fluid Pipeline Quality			
	psid	(Bard)	psid	(Bard)		
Liquid	1000 <sup>1</sup>	(69) <sup>1</sup>	600 <sup>1</sup>	(41) <sup>1</sup>	Metal-Stellited Unbalanced	S1
	1000 <sup>1</sup>	(69) <sup>1</sup>	400 <sup>1</sup>	(28) <sup>1</sup>	Metal Unbalanced <sup>1</sup>	S1
	600	(41)	N/R	N/R	Composition Balanced	S3, S3B, S3E
Gas	3000 <sup>1</sup>	(207) <sup>1</sup>	2400 <sup>1</sup>	(166) <sup>1</sup>	Metal-Stellited Unbalanced	S1
	3000 <sup>1</sup>	(207) <sup>1</sup>	600 <sup>1</sup>	(41) <sup>1</sup>	Metal Unbalanced	S1
	3000 @ -20° to +70°F (207 @ -29° to +21°C)		N/R		Composition TFE Balanced	S3, S3B, S3E, S3S
	2500 @ +100°F (173 @ +38°C)					
	2000 @ +150°F (138 @ +66°C)					
	3000 @ +70° to +200°F (207 @ +93°C)		N/R		Composition Nylon Balanced	S3Y

<sup>1</sup> Minimum outlet (P<sub>2</sub>) pressure levels apply to unbalanced, metal seat constructions, which may override pressure drop capability. N/R: Not recommended.

**TABLE 3  
APPLICATIONS**

Fluid	Recommended Construction	Trim Designation Number
Air or Industrial Chemicals	Clean Fluid; Balanced Composition Seat	S3, S3Y
Chemicals	Clean Fluid; Balanced Composition Seat	S3, S3Y
	Unclean Fluid; Unbalanced Metal Seat	S1
Hydrocarbon Gas or Liquids	Clean Fluid; Balanced Composition Seat	S3, S3Y
	Unclean Fluid; Unbalanced Metal Seat	S1
Water and Condensate 35° to 180°F (2° to 82°C)	Balanced Composition Seat	S3, S3Y
All Fluids except Oxygen †	Balanced Composition Seat	S3B, S3E

† Process Fluid must be compatible with O-ring material.

**TABLE 4  
STAINLESS STEEL TRIM MATERIAL COMBINATIONS**

Part	Stainless Steel Trim Designation Number					
	Unbalanced Metal	Balanced-Composition				
		S1	S3	S3B	S3E	S3Y (H2, He)
Cylinder	316 SST	316 SST	316 SST	316 SST	316 SST	316 SST
Piston	316 SST	316 SST	316 SST	316 SST	316 SST	316 SST
Seat Disc	None	TFE	TFE	TFE	Nylon	TFE
Piston Spring	302 SST	302 SST	302 SST	302 SST	302 SST	302 SST
Cylinder Gasket	Grafoil®	Grafoil®	Grafoil®	Grafoil®	Grafoil®	Gylon
Pressure Piston	316 SST	316 SST	316 SST	316 SST	316 SST	316 SST
Body Cap	<sup>1</sup> See below	<sup>1</sup> See below	<sup>1</sup> See below	<sup>1</sup> See below	<sup>1</sup> See below	<sup>1</sup> See below
Quad Ring	N/A	FKM	FKM	FKM	FKM	Silicone
O-rings	FKM	FKM	Buna-N	EPDM	FKM	Silicone
Backup Ring(s)	TFE	TFE	TFE	TFE	TFE	TFE
Temperature Range	-20 to +400° F (-29 to +205° C)	-20 to +150° F (-29 to +66° C)	-40 to +150° F (-40 to +66° C)	-70 to +150° F (-57 to +66° C)	+70 to +200° F (+21 to +93° C)	-135 to +150° F (-93 to +66° C)

<sup>1</sup> Brass body cap for aluminum bronze body - 316SST body cap for SST bodies.

<sup>2</sup> S3S Trim requires 316 SST body cap bolting, 316 SST adjusting screw & handle & a 316 SST spring button.

N/A: Not applicable FKM - Fluorocarbon Elastomer

® Grafoil is a registered trademark of the Union Carbide Corporation.

**NOTE:** Cashco, Inc. does not recommend metal seated trim on any service where the flow will be dead ended downstream of the pressure reducing regulator.

**TABLE 5  
OUTLET PRESSURE LIMITS – SAFETY RELIEF VALVE  
SIZING AND SELECTION <sup>1</sup>**

Size	Material	Range Spring		Emergency Over-Pressure Level <sup>2</sup>				Maximum Cv with Valve Plug Wide Open
				Pressure		Temperature		
		psig	(Barg)	psig	(Barg)	°F	(°C)	
All	AL BRZ/BRZ	All	All	3300	(228)	-20 to +200	(-29 to +93)	2.0
				2970	(205)	+300	(+149)	
				2750	(190)	+400	(+205)	
	SST/BRZ	All	All	3300	(228)	-20 to +200	(-29 to +93)	
				3080	(212)	+300	(+149)	
				2750	(190)	+400	(+205)	

<sup>1</sup> Sizing and setpoint data supplied to protect Model 345 regulator. Process application may require lower setpoint.

<sup>2</sup> Safety relief valve (SRV) must be provided if it is possible to attain this pressure level upstream of the Model 345; must include SRV pressure build up over SRV setpoint. Internal mechanical damage may result if over-pressure level is exceeded.

**TABLE 6  
Cv AT FLOWING PRESSURE (F<sub>L</sub> = .945)**

Range Spring		Flowing Outlet Pressure P <sub>2</sub>		All Sizes	
psig	(Barg)	psig	(Barg)	Droop	
				10%	20%
50 – 150 *	(3.4-10.3)	50	(3.4)	.43	.87
		75	(5.2)	.58	1.10
		100	(6.9)	.70	1.28
		125	(8.6)	.83	1.45
		150	(10.3)	1.12	1.80
125 – 250 *	(8.6-17.2)	200	(13.8)	1.28	1.80
200 – 600	(13.8-41.4)	250	(17.2)	.50	.96
		300	(20.7)	.57	1.08
		400	(27.6)	.74	1.27
		500	(34.5)	.88	1.46
500-1000	(34.5-69.0)	750	(51.7)	.74	1.27
900-3000 **	(62-207)	1000	(69.0)	.60	.90
		1500	(103)	.58	1.11
		2000	(138)	.75	1.28
		2500	(172)	.88	1.46
		3000	(207)	1.05	1.65

\* The Model 345 contains no diaphragm. If the S1 unbalanced trim is utilized, then an additional consideration or "unbalanced effect" must be included along with "droop". As inlet (P<sub>1</sub>) pressure varies, then outlet (P<sub>2</sub>) pressure setpoint will vary in a **negative** 5:1 ratio.

Example: P<sub>1</sub>=2500psig                      3000-2500 = 500psi increase  
                   P<sub>2</sub>= 500psig at cond.#1            at 5:1 (P<sub>1</sub>:P<sub>2</sub>) ratio > 500/5 = 100psi  
 If P<sub>1</sub> increases to 3000psig                New P<sub>2</sub> = 500-100 = 400psig  
                   P<sub>2</sub> becomes ?? at cond. #2

If P<sub>1</sub> increases, P<sub>2</sub> decreases, likewise if P<sub>1</sub> decreases, P<sub>2</sub> increases.

Therefore, the lower two range springs are not allowed to be utilized with unbalanced trim.

If S3<sub>u</sub>, balanced trim is utilized, the "unbalanced effect" is essentially zero and may be neglected.

\*\* 900 - 3000 psig range spring not available with S3S Trim.

**TABLE 7**  
**AIR CAPACITIES IN SCFH - (All Sizes)**  
**S.G. = 1.0 TEMP. = 60°F F<sub>L</sub> = .945**

Outlet Flowing Pressure		Inlet Pressure		1/2" (DN15) Body		3/4" (DN20) Body		1" (DN25) Body	
psig	(Barg)	psig	(Barg)	10% Droop	20% Droop	10% Droop	20% Droop	10% Droop	20% Droop
50	(3.4)	500	(34.5)	7600	15400	7600	15400	7600	15400
		625	(43.1)	9500	19300	9500	19300	9500	19300
		750	(51.7)	11400	SONIC	11400	23100	11400	23100
		1000	(69.0)	15300	SONIC	15300	30900	15300	30900
		1250	(86.2)	19100	SONIC	19100	SONIC	19100	38600
		1500	(103)	SONIC	SONIC	SONIC	SONIC	SONIC	SONIC
		1750	(121)	SONIC	SONIC	SONIC	SONIC	SONIC	SONIC
		2000	(137)	SONIC	SONIC	SONIC	SONIC	SONIC	SONIC
		2250	(155)	SONIC	SONIC	SONIC	SONIC	SONIC	SONIC
		2500	(172)	SONIC	SONIC	SONIC	SONIC	SONIC	SONIC
		2750	(189)	SONIC	SONIC	SONIC	SONIC	SONIC	SONIC
		3000	(207)	SONIC	SONIC	SONIC	SONIC	SONIC	SONIC
		3500	(241)	SONIC	SONIC	SONIC	SONIC	SONIC	SONIC
		4000	(276)	SONIC	SONIC	SONIC	SONIC	SONIC	SONIC
75	(5.2)	500	(34.5)	10300	19500	10300	19500	10300	19500
		625	(43.1)	12800	24300	12800	24300	12800	24300
		750	(51.7)	15400	24300	15400	29200	15400	29200
		1000	(69.0)	20600	SONIC	20600	39000	20600	39000
		1250	(86.2)	25800	SONIC	25800	48800	25800	48800
		1500	(103)	SONIC	SONIC	31000	SONIC	31000	58800
		1750	(121)	SONIC	SONIC	36200	SONIC	36200	68700
		2000	(137)	SONIC	SONIC	41500	SONIC	41500	78700
		2250	(155)	SONIC	SONIC	46800	SONIC	46800	88800
		2500	(172)	SONIC	SONIC	SONIC	SONIC	52200	SONIC
		2750	(189)	SONIC	SONIC	SONIC	SONIC	57500	SONIC
		3000	(207)	SONIC	SONIC	SONIC	SONIC	62600	SONIC
		3500	(241)	SONIC	SONIC	SONIC	SONIC	72800	SONIC
		4000	(276)	SONIC	SONIC	SONIC	SONIC	82800	SONIC
100	(6.9)	500	(34.5)	12400	22600	12400	22600	12400	22600
		625	(43.1)	15500	28300	15500	28300	15500	28300
		750	(51.7)	18600	34000	18600	34000	18600	34000
		1000	(69.0)	24800	SONIC	24800	45400	24800	45400
		1250	(86.2)	31100	SONIC	31100	56800	31100	56800
		1500	(103)	SONIC	SONIC	37400	SONIC	37400	68400
		1750	(121)	SONIC	SONIC	43700	SONIC	43700	80000
		2000	(138)	SONIC	SONIC	50100	SONIC	50100	91600
		2250	(155)	SONIC	SONIC	56500	SONIC	56500	103300
		2500	(172)	SONIC	SONIC	63000	SONIC	63000	SONIC
		2750	(190)	SONIC	SONIC	SONIC	SONIC	69400	SONIC
		3000	(207)	SONIC	SONIC	SONIC	SONIC	75500	SONIC
		3500	(241)	SONIC	SONIC	SONIC	SONIC	87900	SONIC
		4000	(276)	SONIC	SONIC	SONIC	SONIC	100000	SONIC
125	(8.6)	500	(34.5)	14700	25600	14700	25600	14700	25600
		625	(43.1)	18400	32100	18400	32100	18400	32100
		750	(51.7)	22100	38500	22100	38500	22100	38500
		1000	(69.0)	29400	SONIC	29400	51400	29400	51400
		1250	(86.2)	36800	SONIC	36800	64400	36800	64400
		1500	(103)	44300	SONIC	44300	77400	44300	77400
		1750	(121)	SONIC	SONIC	51900	SONIC	51900	90600
		2000	(138)	SONIC	SONIC	59400	SONIC	59400	103800
		2250	(155)	SONIC	SONIC	67000	SONIC	67000	117100
		2500	(172)	SONIC	SONIC	74600	SONIC	74600	130400
		2750	(190)	SONIC	SONIC	SONIC	SONIC	82300	SONIC
		3000	(207)	SONIC	SONIC	SONIC	SONIC	89600	SONIC
		3500	(241)	SONIC	SONIC	SONIC	SONIC	104200	SONIC
		4000	(276)	SONIC	SONIC	SONIC	SONIC	118500	SONIC
150	(10.3)	500	(34.5)	19700	31700	19700	31700	19700	31700
		625	(43.1)	24800	39800	24800	39800	24800	39800
		750	(51.7)	29800	47900	29800	47900	29800	47900
		1000	(69.0)	39700	SONIC	39700	63900	39700	63900
		1250	(86.2)	49700	SONIC	49700	79900	49700	79900
		1500	(103)	SONIC	SONIC	59800	SONIC	59800	96100
		1750	(121)	SONIC	SONIC	70000	SONIC	70000	112400
		2000	(138)	SONIC	SONIC	80200	SONIC	80200	128800
		2250	(155)	SONIC	SONIC	90400	SONIC	90400	145300
		2500	(172)	SONIC	SONIC	SONIC	SONIC	100700	161900
		2750	(190)	SONIC	SONIC	SONIC	SONIC	111100	SONIC
		3000	(207)	SONIC	SONIC	SONIC	SONIC	120900	SONIC
		3500	(241)	SONIC	SONIC	SONIC	SONIC	140700	SONIC
		4000	(276)	SONIC	SONIC	SONIC	SONIC	159900	SONIC
200	(13.8)	500	(34.5)	22100	31100	22100	31100	22100	31100
		625	(43.1)	28100	39500	28100	39500	28100	39500
		750	(51.7)	34000	47800	34000	47800	34000	47800
		1000	(69.0)	45400	63900	45400	63900	45400	63900
		1250	(86.2)	56800	SONIC	56800	79900	56800	79900
		1500	(103)	68400	SONIC	68400	96100	68400	96100
		1750	(121)	SONIC	SONIC	80000	112400	80000	112400
		2000	(138)	SONIC	SONIC	91600	SONIC	91600	128800
		2250	(155)	SONIC	SONIC	103300	SONIC	103300	145300
		2500	(172)	SONIC	SONIC	115100	SONIC	115100	161900
		2750	(190)	SONIC	SONIC	SONIC	SONIC	127000	178500
		3000	(207)	SONIC	SONIC	SONIC	SONIC	138100	194300
		3500	(241)	SONIC	SONIC	SONIC	SONIC	160800	SONIC
		4000	(276)	SONIC	SONIC	SONIC	SONIC	182800	SONIC
250	(17.2)	500	(34.5)	8300	16000	8300	16000	8300	16000
		625	(43.1)	10800	20700	10800	20700	10800	20700
		750	(51.7)	13200	25300	13200	25300	13200	25300
		1000	(69.0)	17700	34000	17700	34000	17700	34000
		1250	(86.2)	22200	42600	22200	42600	22200	42600
		1500	(103)	26700	51300	26700	51300	26700	51300
		1750	(121)	31200	60000	31200	60000	31200	60000
		2000	(138)	35800	68700	35800	68700	35800	68700
		2250	(155)	40400	77500	40400	77500	40400	77500
		2500	(172)	45000	SONIC	45000	86300	45000	86300
		2750	(190)	49600	SONIC	49600	95200	49600	95200
		3000	(207)	54000	SONIC	54000	103600	54000	103600
		3500	(241)	62800	SONIC	62800	120600	62800	120600
		4000	(276)	71400	SONIC	71400	137100	71400	137100

NOTE: Where "SONIC" is indicated within the above capacity tables, outlet velocity with Schedule 160 pipe has reached sonic velocity of 1118 fps. Additional flow cannot be obtained, and pipeline velocity is in excess of customary pipe velocity design limits. Flow will be approximately the last indicated value in the column above "SONIC".

**TABLE 7 (cont.)**  
**AIR CAPACITIES IN SCFH - (All Sizes)**  
**S.G. = 1.0 TEMP. = 60°F F<sub>L</sub> = .945**

Outlet Flowing Pressure		Inlet Pressure		1/2" (DN15) Body		3/4" (DN20) Body		1" (DN25) Body					
psig	(Barg)	psig	(Barg)	10% Droop	20% Droop	10% Droop	20% Droop	10% Droop	20% Droop				
300	(20.7)	500	(34.5)	8900	16900	8900	16900	8900	16900				
		625	(43.1)	12000	22700	12000	22700	12000	22700				
		750	(51.7)	14800	28000	14800	28000	14800	28000				
		1000	(69.0)	20100	38100	20100	38100	20100	38100				
		1250	(86.2)	25300	47900	25300	47900	25300	47900				
		1500	(103)	30400	57700	30400	57700	30400	57700				
		1750	(121)	35600	67500	35600	67500	35600	67500				
		2000	(138)	40800	77300	40800	77300	40800	77300				
		2250	(155)	46000	87200	46000	87200	46000	87200				
		2500	(172)	51300	97100	51300	97100	51300	97100				
		2750	(190)	56500	SONIC	56500	107100	56500	107100				
		3000	(207)	61500	SONIC	61500	116600	61500	116600				
3500	(241)	71600	SONIC	71600	135600	71600	135600						
4000	(276)	81400	SONIC	81400	154200	81400	154200						
400	(27.6)	500	(34.5)	9000	15500	9000	15500	9000	15500				
		625	(43.1)	14100	24100	14100	24100	14100	24100				
		750	(51.7)	18200	31300	18200	31300	18200	31300				
		1000	(69.0)	25600	44000	25600	44000	25600	44000				
		1250	(86.2)	32600	56000	32600	56000	32600	56000				
		1500	(103)	39400	67700	39400	67700	39400	67700				
		1750	(121)	46200	79300	46200	79300	46200	79300				
		2000	(138)	53000	90900	53000	90900	53000	90900				
		2250	(155)	59700	102500	59700	102500	59700	102500				
		2500	(172)	66600	114200	66600	114200	66600	114200				
		2750	(190)	73400	126000	73400	126000	73400	126000				
		3000	(207)	79900	SONIC	79900	137100	79900	137100				
3500	(241)	92900	SONIC	92900	159500	92900	159500						
4000	(276)	105700	SONIC	105700	181300	105700	181300						
500	(34.5)	625	(43.1)	13500	22300	13500	22300	13500	22300				
		750	(51.7)	19600	32500	19600	32500	19600	32500				
		1000	(69.0)	29400	48800	29400	48800	29400	48800				
		1250	(86.2)	38100	63300	38100	63300	38100	63300				
		1500	(103.4)	46500	77200	46500	77200	46500	77200				
		1750	(120.7)	54800	90900	54800	90900	54800	90900				
		2000	(137.9)	62900	104400	62900	104400	62900	104400				
		2250	(155.2)	71000	117900	71000	117900	71000	117900				
		2500	(172.4)	79100	131300	79100	131300	79100	131300				
		2750	(189.6)	87300	144800	87300	144800	87300	144800				
		3000	(206.9)	95000	157600	95000	157600	95000	157600				
		3500	(241.4)	110500	SONIC	110500	183400	110500	183400				
4000	(275.9)	125700	SONIC	125700	208500	125700	208500						
750	(51.7)	1000	(69.0)	19800	34400	19800	34000	19800	34000				
		1250	(86.2)	29100	50000	29100	50000	29100	50000				
		1500	(103)	37200	63900	37200	63900	37200	63900				
		1750	(121)	44800	76800	44800	76800	44800	76800				
		2000	(138)	52000	89300	52000	89300	52000	89300				
		2250	(155)	59200	101500	59200	101500	59200	101500				
		2500	(172)	66200	113600	66200	113600	66200	113600				
		2750	(190)	73200	125700	73200	125700	73200	125700				
		3000	(207)	79800	136900	79800	136900	79800	136900				
		3500	(241)	92900	159500	92900	159500	92900	159500				
		4000	(276)	105700	181300	105700	181300	105700	181300				
		1000	(69.0)	1250	(86.2)	18400	27600	18400	27600	18400	27600		
1500	(103)			26800	40200	26800	40200	26800	40200				
1750	(121)			33900	50900	33900	50900	33900	50900				
2000	(138)			40400	60700	40400	60700	40400	60700				
2250	(155)			46600	70000	46600	70000	46600	70000				
2500	(172)			52700	79000	52700	79000	52700	79000				
2750	(190)			58600	87900	58600	87900	58600	87900				
3000	(207)			64100	96200	64100	96200	64100	96200				
3500	(241)			75100	112600	75100	112600	75100	112600				
4000	(276)			85600	128400	85600	128400	85600	128400				
1500	(103.4)			1750	(121)	21700	41600	21700	41600	21700	41600		
				2000	(138)	31300	60000	31300	60000	31300	60000		
		2250	(155)	39200	75000	39200	75000	39200	75000				
		2500	(172)	46300	88600	46300	88600	46300	88600				
		2750	(190)	52900	101200	52900	101200	52900	101200				
		3000	(207)	58900	112800	58900	112800	58900	112800				
		3500	(241)	70500	135000	70500	135000	70500	135000				
		4000	(276)	81400	155700	81400	155700	81400	155700				
		2000	(137.9)	2250	(155)	32500	55400	32500	55400	32500	55400		
				2500	(172)	46600	79600	46600	79600	46600	79600		
				2750	(190)	58000	99000	58000	99000	58000	99000		
				3000	(207)	67800	115700	67800	115700	67800	115700		
3500	(241)			85200	145500	85200	145500	85200	145500				
4000	(276)			100800	172100	100800	172100	100800	172100				
2500	(172.4)			2750	(190)	42700	70900	42700	70900	42700	70900		
				3000	(207)	60800	100900	60800	100900	60800	100900		
				3500	(241)	87700	145500	87700	145500	87700	145500		
				4000	(276)	109300	181400	109300	181400	109300	181400		
				3000	(206.9)	3500	(241)	79000	124200	79000	124200	79000	124200
						4000	(276)	113200	177800	113200	177800	113200	177800

Metric Conversion Factor: SCFH / 35.31 = Sm<sup>3</sup>/Hr; SCFH / 37.32 = Nm<sup>3</sup>/Hr

**TABLE 8**  
**WATER CAPACITIES IN GPM - (All Sizes)**  
**S.G. = 1.0 TEMP. = 60°F F<sub>L</sub> =.945**

Outlet Flowing Pressure		Inlet Pressure		1/2" (DN15) Body		3/4" (DN20) Body		1" (DN25) Body	
psig	(Barg)	psig	(Barg)	10% Droop	20% Droop	10% Droop	20% Droop	10% Droop	20% Droop
50	(3.4)	500	(34.5)	9.1	18.5	9.1	18.5	9.1	18.5
		625	(43.1)	CAV	CAV	CAV	CAV	CAV	CAV
75	(5.2)	500	(34.5)	12.0	22.7	12.0	22.7	12.0	22.7
		625	(43.1)	13.6	25.8	13.6	25.8	13.6	25.8
		750	(51.7)	HI DP	HI DP	HI DP	HI DP	HI DP	HI DP
		875	(60.3)	CAV	CAV	CAV	CAV	CAV	CAV
100	(6.9)	500	(34.5)	14.0	25.6	14.0	25.6	14.0	25.6
		625	(43.1)	16.0	29.3	16.0	29.3	16.0	29.3
		750	(51.7)	HI DP	HI DP	HI DP	HI DP	HI DP	HI DP
125	(8.6)	500	(34.5)	16.1	28.1	16.1	28.1	16.1	28.1
		625	(43.1)	18.6	32.4	18.6	32.4	18.6	32.4
		750	(51.7)	HI DP	HI DP	HI DP	HI DP	HI DP	HI DP
150	(10.3)	500	(34.5)	21.0	33.7	21.0	33.7	21.0	33.7
		625	(43.1)	24.4	39.2	24.4	39.2	24.4	39.2
		750	(51.7)	27.4	44.1	27.4	44.1	27.4	44.1
		875	(60.3)	HI DP	HI DP	HI DP	HI DP	HI DP	HI DP
200	(13.8)	500	(34.5)	22.2	31.2	22.2	31.2	22.2	31.2
		625	(43.1)	26.4	37.1	26.4	37.1	26.4	37.1
		750	(51.7)	30.0	42.2	30.0	42.2	30.0	42.2
		875	(60.3)	HI DP	HI DP	HI DP	HI DP	HI DP	HI DP
250	(17.2)	500	(34.5)	7.9	15.2	7.9	15.2	7.9	15.2
		625	(43.1)	9.7	18.6	9.7	18.6	9.7	18.6
		750	(51.7)	11.2	21.5	11.2	21.5	11.2	21.5
		875	(60.3)	HI DP	HI DP	HI DP	HI DP	HI DP	HI DP
300	(20.7)	500	(34.5)	8.1	15.3	8.1	15.3	8.1	15.3
		625	(43.1)	10.3	19.5	10.3	19.5	10.3	19.5
		750	(51.7)	12.1	22.9	12.1	22.9	12.1	22.9
		875	(60.3)	13.7	25.9	13.7	25.9	13.7	25.9
		1000	(69.0)	HI DP	HI DP	HI DP	HI DP	HI DP	HI DP

NOTE: Where "CAV" is indicated within the above capacity tables, the water has reached full cavitation, and flow is choked.  
Metric Conversion Factor: GPM X 3.785 = LPM

**TABLE 9**  
**OIL CAPACITIES IN GPM - (All Sizes)**  
**S.G. = 0.85 TEMP. = 60°F F<sub>L</sub> =.945**

Outlet Flowing Pressure		Inlet Pressure		1/2" (DN15) Body		3/4" (DN20) Body		1" (DN25) Body	
psig	(Barg)	psig	(Barg)	10% Droop	20% Droop	10% Droop	20% Droop	10% Droop	20% Droop
50	(3.4)	500	(34.5)	9.7	19.7	9.7	19.7	9.7	19.7
		625	(43.1)	CAV	CAV	CAV	CAV	CAV	CAV
75	(5.2)	500	(34.5)	12.7	24.2	12.7	24.2	12.7	24.2
		625	(43.1)	14.5	27.5	14.5	27.5	14.5	27.5
		750	(51.7)	HI DP	HI DP	HI DP	HI DP	HI DP	HI DP
100	(6.9)	500	(34.5)	14.9	27.3	14.9	27.3	14.9	27.3
		625	(43.1)	17.1	31.3	17.1	31.3	17.1	31.3
		750	(51.7)	HI DP	HI DP	HI DP	HI DP	HI DP	HI DP
125	(8.6)	500	(34.5)	17.1	29.9	17.1	29.9	17.1	29.9
		625	(43.1)	19.8	34.6	19.8	34.6	19.8	34.6
		750	(51.7)	HI DP	HI DP	HI DP	HI DP	HI DP	HI DP
150	(10.3)	500	(34.5)	22.3	35.9	22.3	35.9	22.3	35.9
		625	(43.1)	26.0	41.8	26.0	41.8	26.0	41.8
		750	(51.7)	29.2	47.0	29.2	47.0	29.2	47.0
		875	(60.3)	HI DP	HI DP	HI DP	HI DP	HI DP	HI DP
200	(13.8)	500	(34.5)	23.6	33.2	23.6	33.2	23.6	33.2
		625	(43.1)	28.1	39.6	28.1	39.6	28.1	39.6
		750	(51.7)	32.0	45.0	32.0	45.0	32.0	45.0
		875	(60.3)	HI DP	HI DP	HI DP	HI DP	HI DP	HI DP
250	(17.2)	500	(34.5)	8.4	16.2	8.4	16.2	8.4	16.2
		625	(43.1)	10.3	19.8	10.3	19.8	10.3	19.8
		750	(51.7)	11.9	22.9	11.9	22.9	11.9	22.9
		875	(60.3)	HI DP	HI DP	HI DP	HI DP	HI DP	HI DP
300	(20.7)	500	(34.5)	8.6	16.3	8.6	16.3	8.6	16.3
		625	(43.1)	11.0	20.8	11.0	20.8	11.0	20.8
		750	(51.7)	12.9	24.4	12.9	24.4	12.9	24.4
		875	(60.3)	14.6	27.6	14.6	27.6	14.6	27.6
		1000	(69.0)	HI DP	HI DP	HI DP	HI DP	HI DP	HI DP

NOTE: Where "CAV" is indicated within the above capacity tables, the oil has reached full cavitation, and flow is choked.  
Metric Conversion Factor: GPM X 3.785 = LPM



TABLE 10

STAINLESS STEEL FLANGED PRESSURE vs. TEMPERATURE RATINGS – ASME B31.3

Temperature °F	English Units				Metric Units				Temperature °C
	Working Pressure Classes								
	300 psig	600 psig	900 psig	1500 psig	300 Barg	600 Barg	900 Barg	1500 Barg	
-20 to +100	720	1440	2160	3600	49.6	99.3	148.9	248.2	-29 to +38
200	620	1240	1860	3095	42.7	85.5	128.2	213.4	94
300	560	1120	1680	2795	38.6	77.2	115.8	192.7	149
400	515	1025	1540	2570	35.5	70.7	106.2	177.2	205

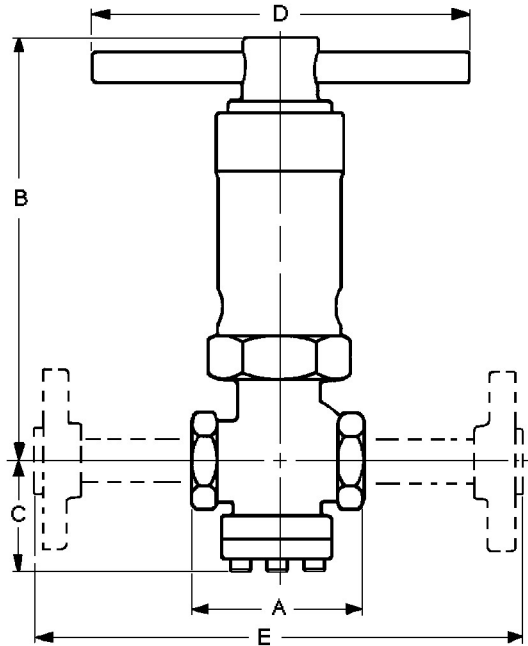

Size (Inches)	DIMENSIONS – ENGLISH UNITS (In)						Shipping Weight *** (lb)
	A	B	C	D	E *	E **	
1/2"	4.50	11.00	3.25	10.00	13.00	14.00	27
3/4"							
1"							
Size (DN)	DIMENSIONS – METRIC UNITS (mm)						Shipping Weight *** (kg)
	A	B	C	D	E *	E **	
(15)	114	279	85	254	330	356	12.2
(20)							
(25)							

\* Opt -30 Face-to-face dimensions are the same for all flange pressure classes.

\*\* Opt -34 Special 14" face to face flanged dim for all flange pressure classes.

\*\*\* Weights do not include flanges.

---

## NOTES

The contents of this publication are presented for informational purposes only, and while every effort has been made to ensure their accuracy, they are not to be construed as warranties or guarantees, express or implied, regarding the products or services described herein or their use or applicability. We reserve the right to modify or improve the designs or specifications of such product at any time without notice. Cashco, Inc. does not assume responsibility for the selection, use or maintenance of any product. Responsibility for proper selection, use and maintenance of any Cashco, Inc. product remains solely with the purchaser.

# MODEL 345 PRODUCT CODER 02/07/20

An "X" in POS 12 followed by a 5-digit control number overrides remaining selections.

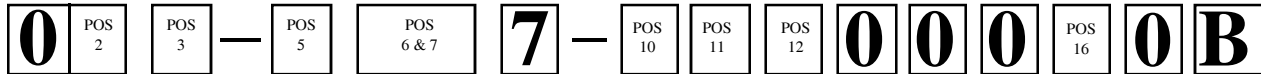

POSITION 2 - GASKETS * & SERVICE		
Gaskets - Service	Options	CODE
Standard : Graphite / NBR - Non-Oxygen	--	B
FKM - Primarily for Oxygen	-45	D
* Refer to Tech Bulletin for temperature limits. (S3S Trim has Gylon gasket)		

POSITION 3 - SIZES		
Size		CODE
in	(DN)	
1/2"	(15)	4
3/4"	(20)	5
1"	(25)	6

POSITION 5 - BODY / SPRING CHAMBER MATERIALS	
Body / Sp. Ch.	CODE
Al Brz/Brz (Not for use with oxygen service.)	K
SST/Brz	L

POSITION 6 & 7 - TRIM DESIGNATION NUMBERS			
Stainless Steel Trim			
Unbalanced		Balanced	
Desig.	CODE	Desig.	CODE
S1	S1	S3	S3
		S3B	3B
		S3E	3E
		S3Y	3Y
		S3S	3S

POSITION 10 - END CONNECTIONS	
Description	CODE
NPT - Screwed	1
-30 Opt.- 300 LB RF Flgs. *	7
-30 Opt.- 600 LB RF Flgs. *	8
-30 Opt.- 900 LB RF Flgs. *	9
-30 Opt.- 1500 LB RF Flgs. *	A
-34 Opt. - 300 LB RF Flgs. 14" F to F Dim. *	W
-34 Opt. - 600 LB RF Flgs. 14" F to F Dim. *	Y
-34 Opt. - 900 LB RF Flgs. 14" F to F Dim. *	Z
-34 Opt. - 1500 LB RF Flgs. 14" F to F Dim. *	U
* Nipples & flanges of same material as body. SST bodies only.	

POSITION 11 - RANGE SPRINGS		
Steel Range Spring		CODE
psig	(Barg)	
50 - 150 *	(3.4-10.3)	1
125 - 250 *	(8.6-17.2)	2
200 - 600	(13.8-41.4)	3
500 -1000	(34.5-69.0)	4
900 -3000 **	(62-207)	5
* DO NOT use with S1 Trim. ** 900 - 3000 psig range spring not available with S3S Trim.		

POSITION 12 - FEATURE OPTIONS		
Description	Option	CODE
No Option	-	0
Stellited Seat Surfaces (SST S1 Trim Only).	-15	A
For Special Construction Contact Cashco for Special Product Code.	SPQ	X

POSITION 16 - CERTIFICATE OPTIONS		
Description	Option	CODE
No Option	-	0
* Special Cleaning: Per Cashco Spec #S-1134. Suitable for Oxygen Service.	-55	M
Special Cleaning: Per Cashco Spec #S-1542.	-56	N
* For use with SST bodies only. Must use Code D in Position 2.		

**\* For information on ATEX see pages 8 & 9 on the IOM.**

Cashco, Inc.  
P.O. Box 6  
Ellsworth, KS 67439-0006  
PH (785) 472-4461  
Fax. # (785) 472-3539  
www.cashco.com  
email: sales@cashco.com  
Printed in U.S.A. 345-TB

Cashco GmbH  
Handwerkerstrasse 15  
15366 Hoppegarten, Germany  
PH +49 3342 30968 0  
Fax. No. +49 3342 30968 29  
www.cashco.com  
email: germany@cashco.com

Cashco do Brasil, Ltda.  
Al.Venus, 340  
Indaiatuba - Sao Paulo, Brazil  
PH +55 11 99677 7177  
Fax. No.  
www.cashco.com  
email: brazil@cashco.com