



ISO Registered Company

# MODEL 1000LP

## LOW PRESSURE REDUCING REGULATOR

The Model 1000LP is a high capacity, low pressure regulator used to control downstream pressure between 1 and 30 psig (.07 and 2.1 Barg). Sizes are from 1/2" through 1" (DN15 through DN25).

The 1000LP is the low pressure version of the Cashco 1000HP reducing regulator. The designs are essentially equal, except that the 1000LP has a larger diaphragm area which is required for the lower operating pressures.

The unique internals design allows use in a multitude of applications, including process fluids, that normal pressure reducing regulators can not match.

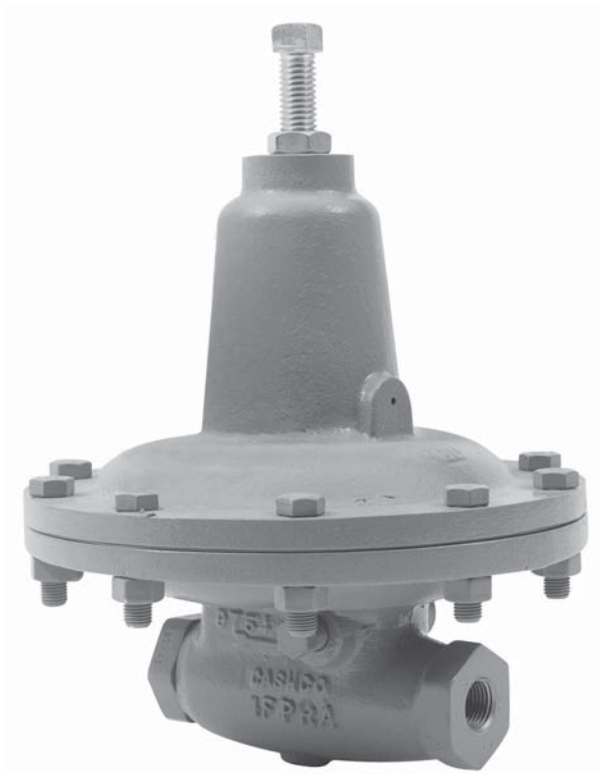

Model 1000LP

### FEATURES

- Streamlined Flow Path:** Straight-thru flow path reduces internal turbulence and resistance to flow, increasing stability and capacity.
- High Inlet Pressure Range:** Standard construction allows inlet pressures up to 450 psig (31.0 Barg).
- High Outlet Pressures:** Controlled outlet pressure between 1–30 psig (.07–2.1 Barg).
- High Pressure Drop:** Standard construction with extended guiding allows pressure drop up to 450 psid (31.0 Bard). This regulator is routinely applied in severe service conditions.
- Flow-to-Open Plug:** Provides unmatched rangeability – far greater than competitive flow-to-close designs. Highly stable at either high or low flow rates.
- Versatility:** Four available body materials and eighteen trim material selections allow usage in a multitude of various fluids. Optional constructions extend the capability.
- Protected Diaphragm Zone:** Internal arrangement isolates the diaphragm from direct impingement, negating any flow induced instability at either low or high flow rates. Allows incorporation of dynamic boost from jet section. Uniformly registers pressure on the diaphragm.

### APPLICATIONS

Used primarily in utilities services – saturated steam, industrial gases, fuel gases, compressed air, or water condensate. Also used in sour gas, chemical and other process services.

Reference Technical Bulletin 1000HP-BASIC-TB for outlet pressures in the range of 10–30 psig (.69–2.1 Barg), as this range overlaps with Model 1000LP.

**Body Sizes:** 1/2", 3/4", 1"; (DN15, 20, 25).

**End Connections:** Standard – NPT female.  
 Opt-31: BSP female.  
 Opt-30: 150# or 300# RF flanged.  
 Opt-32: Extended plain end nipples.  
 Opt-34: 14" Face to Face Flange Dim.

**Body/Spring Chamber Material Combinations:** Uniform – CI/CI, BRZ/BRZ, CS/CS and SST/SST.  
 Combinations – CS/CI, BRZ/CI, SST/CI, and SST/CS.  
 CI = Cast grey iron  
 CS = Cast carbon steel  
 BRZ = Cast bronze  
 SST = Cast stainless steel

See Table 4 for material specifications

**Trim Designs:** Metal seated or composition seat. Metal or composition diaphragms.  
 "B\_" series designations – BRZ, BR, SST; see Table 6 for materials.  
 "S\_" series designations – SST, CS; see Table 7 for materials.

**Body/Cylinder Material Combinations:** CI/BRZ, CI/SST.  
 BRZ/BRZ.  
 CS/SST.  
 SST/SST.

**Maximum Inlet Pressure:** Dependent only on cylinder material and type of end connection (See Table 8):

BRZ – 400 psig (27.6 Barg)  
 SST – 450 psig (31.0 Barg)

**NOTE:** 1000LP is a flow-to-open (FTO) design; this places an upper limitation on inlet pressure for a given outlet pressure setting.

For body/cylinder/spring chamber construction with:

any BRZ materials –  
 -20°to+400°F(-29°to+205°C).  
any CI materials –  
 -20°to+450°F(-29°to+232°C).  
all CS or SST materials –  
 -20°to+600°F(-29°to+315°C).

**NOTE:** Composition trim materials may lower above ranges.

**Outlet Pressure Operating Range:** Pressure Containment – 50 psig (3.44 Barg), internal damage will occur.  
Max. Operating – 40 psig (2.76 Barg), no internal damage.

**NOTE:** 1000LP is flow-to-open (FTO) design; this places a lower limitation on outlet pressure setting for some inlet pressure levels.

Metal or Composition Seated Designs:  
 "B\_" series trim designations – up to 400 psid (27.6 Bard).  
 "S\_" series trim designations – up to 450 psid (31.0 Bard).

**Maximum Pressure Drop:** Standard: ΔP > 5 psid (.34 Bard).  
Opt-17: ΔP = 1 - 5 psid (.07 - .34 Bard).

**Minimum Pressure Drop:** Minimum = 1 psid (.07 Bard).

**Seat Leakage:** Meets ANSI/FCI 70-2.  
Metal Seated – Class IV.  
Composition Seat – Class VI.

**Capacity:** See Tables 9 through 13 for flow capacity.  
 See Table 2 for "Wide Open Cv"; use for sizing of safety relief device.

**Range Springs:** Epoxy coated steel.

**Diaphragm Flange Bolting:** Standard: High strength, zinc plated, heat treated steel. For all body/spring chamber materials.

**Gaskets:** Required for metal diaphragm constructions only; not required for composition diaphragm construction.

Standard:  
 TFE/Alumina Silicate.

**(Not suitable for oxygen service.)**

T<sub>max</sub> = 450°F (232°C).

Opt-45: TFE gaskets for oxygen service or as alternate.

T<sub>max</sub> = 400°F (205°C).

Opt-46G: Alternate carbon graphite gaskets. T<sub>max</sub> = 600° (315°C).

**Painting:** Standard: All non-corrosion resistant portions to be painted with corrosion resistant epoxy paint per Cashco Spec #S-1606.

Alternate: See Opt-95 or -95OS.

## OPTION SPECIFICATIONS

**Option -1:** CLOSING CAP. A removable ductile iron cap discourages tampering with spring setting. Available only with CI or CS spring chamber materials. Includes a gasket for sealing the closing cap to the spring chamber, a sealing lock nut, and a 1/4" (DN8) NPT female vent connection.

**Option -3:** MANUAL ADJUSTOR & LOCKING LEVER. Use when frequent spring range settings are required. Adjusting screw has handwheel fixed to end, and locking nut is replaced by a locking lever that is easily loosened/tightened.

**Option -12:** REDUCED PORT ORIFICE. Used when high inlet pressure negates use of the standard full port orifice. Also used when oversized body is desired to accommodate piping size. Available in metal seated or composition seat materials, in all "B\_" or "S\_" series trim designations, and in all body sizes. See Tables 10 and 12 for flow capacity in Cv's and maximum inlet pressure.

**Option -14:** INTEGRAL SEAT. Standard pressed-in seat ring-to-cylinder joint is sealed as a path of leakage by brazing or welding. The procedure also serves as a permanent joint for flow conditions where service conditions are "severe", subject to vibration, or thermal cycling.

Seat ring is silver brazed to cylinder for "B\_" series **composition** trim designations, and to 1/2" (DN15) body size cylinders with "S\_" series trim designations. For all other body sizes with "S\_" series designations the seat ring is welded to the cylinder.

Recommended for all hydrogen or helium applications. Recommended when pressure drop exceeds 300 psid (20.7 Bard).

**NOTE:** Opt-14 is included whenever Opt-15, stellite seat is specified.

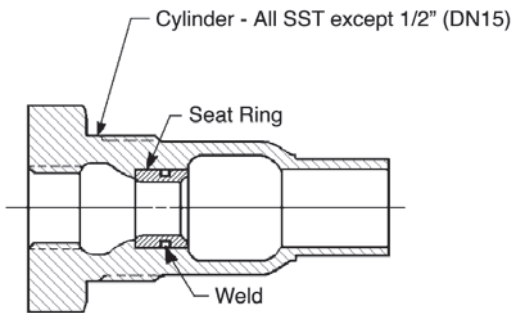
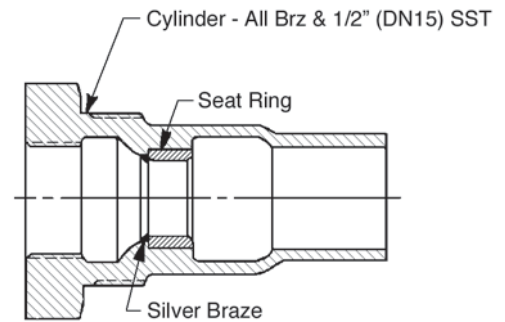

Opt -14 Integral Seat

**Option -15:** STELLITED SEAT SURFACES. Available with metal seated S1 trim only, and with full port orifice or Opt-12 reduced port orifice. Both plug face and seat ring's seat edge are coated with stellite hard surfacing using a flame spray process. Always includes integral seat ring Opt-14. Required for applications when:

1. Liquid flow is flashing and when both outlet pressure  $P_2 \leq 30$  psig (2.1 Barg) and  $\Delta P > 50$  psid (3.5 Bard).
2. Steam service when  $\Delta P > 300$  psid (20.7 Bard).
3. 2-phase flow (liquid + vapor i.e. "wet" steam) at inlet.

**Option -17:** PISTON SPRING. Required for applications where pressure drop is less than 5 psid (.34 Bard). Minimizes plug/cylinder frictional effects. 302 SST material only.

**Option -25:** REMOTE VENTING. Use with hazardous or explosive gases where personnel/equipment safety is at issue when a diaphragm leak occurs. 1/4" (DN8) NPT female connection in spring chamber for piping.

**Option -25S:** VENT SCREEN: Cap (For Opt-25).

**Option -26:** DRAIN HOLE. 1/4" (DN8) NPT drain tap with plug in body underside. Recommend use with highly viscous fluids (above 100 centipoise (Cp)) for downstream piping pressure sensing. Plug material similar to body material. Recommended for flashing liquids.

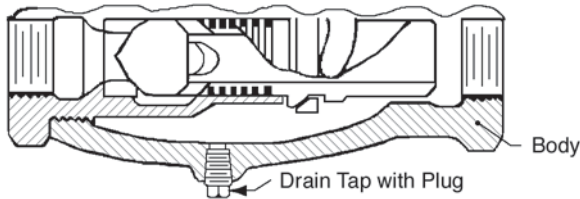

Opt-26 Drain Tap with Plug

**Option -27:** VISCOUS LIQUID SERVICE. Incorporates special valve plug with drilled openings near the "jet effect" zone to stabilize operation for fluids with viscosity greater than 100 Cp. Brass or SST metal seated trim ONLY.

**Option -30:** FLANGED END CONNECTIONS. CS or SST body materials only. Flange and pipe nipple materials of same general chemistry as body material. Available as 150# RF or 300# RF flange configurations. Requires lapped joint-type flange on inlet (cylinder) end. Pipe nipples socket welded to body and cylinder. Outlet connection flange is socket weld-type. See Table 8 for lowered P vs T ratings. (Suitable for NACE service with post-weld, stress relief, heat treatment).

**Option -31:** BSP SCREWED END CONNECTIONS. British Standard Pipe threads per ISO 7/1; used as alternate to NPT ends. Available all sizes and body materials.

**Option -32:** EXTENDED P.E. NIPPLES. Schedule 80 plain end pipe nipples used for field butt or socket welding into pipeline. Pipe nipples of same general chemistry as body material. Short-threaded pipe nipples seal welded to body and cylinder. Adds approximately 8 inches (200 mm) to the face-to-face dimension of standard unit. Use for socket weld pipe systems.

**Option -34:** SPECIAL 14" FACE TO FACE DIMENSION FOR FLANGED END CONNECTIONS. See Opt.-30 for standard face to face dimension.

**Option -40:** NACE CONSTRUCTION. Internal wetted portions meet NACE standard MR0175 for application in sour gas service. Exterior of the unit to not be directly exposed to a sour gas environment, buried, insulated or otherwise denied direct atmospheric exposure. CS/CS or SST/CS body/spring chamber materials ONLY. Acceptable ONLY with S40, S40V, S3, or S3N trim. Not available with Opt-14, Opt-15, or Opt-17.

**Option -45:** PTFE/SILICATE GASKET. Primarily for oxygen service. Limits temperature range to -20° to +400°F (-29° to +205°C). (A gasket is not required when applying a composition diaphragm.)

**Option -46G:** HIGH TEMPERATURE GASKETS. CS or SST body/spring chamber materials only. Utilizes carbon graphite gaskets over standard gaskets. Primarily applied at temperatures over 400°F (205°C) or at customer's request; range of -20° to +600°F (-29° to +315°C).

**Option -55:** SPECIAL CLEANING. BRZ or SST body materials ONLY. Cleaning per Cashco Spec #S-1134 for Oxygen gas Service. **NOTE:** Design Pressure Rating shall not exceed 375 psig (25.8 Barg) when body material is SST and process medium is oxygen.

**Option -56:** SPECIAL CLEANING. Cleaning per Cashco Spec #S-1542. Not suitable for Oxygen Service.

**Option -95:** EPOXY PAINT. Special epoxy painting of all non-corrosion resistant external surfaces per Cashco Spec #S-1547. Utilized in harsh atmospheric conditions.

**Option -95OS:** EPOXY PAINT. Special epoxy painting of all non-corrosion resistant external surfaces per Cashco Spec #S-1687 for OFFSHORE installations.

## TECHNICAL SPECIFICATIONS

**TABLE 1  
RECOMMENDED PRESSURE DROP  
VS. TRIM DESIGN/MATERIALS**

**NOTE:** Consult Factory with Application Details For  $\Delta P$ 's > 450 psid (31 Bard)

**NOTE:** Cashco, Inc. does not recommend metal seated trim on any service where the flow will be dead ended down stream of the pressure reducing regulator.

Fluid	Maximum Inlet Pressure		Operating Pressure Drop Range		Seat Design	Basic Trim Materials	Trim Designation Numbers
	psig	(Barg)	psid	(Barg)			
Liquids (Noncavating)	400	(27.6)	5 - 250	(0.34-17.2)	Soft Seat - All Comp Materials	BRZ/BR	BB, B2, B3, B5, BK
	450	(31.0)	5 - 400	(0.34-27.6)	Soft Seat - All Comp Materials	SST	S3, S3N, S9, S36, SB, S40V
	400	(27.6)	5 - 390	(0.34-26.9)	Metal Seated	BRZ/BR	B1
	450	(31.0)	5 - 440	(0.34-30.3)	Metal Seated	SST	S2, S2N, S0, S1, S5, S40
Gas	400	(27.6)	5 - 390	(0.34-26.9)	Soft Seat - All Comp Materials <b>except SST/TFE</b>	BRZ/BR	BB, B2, B3, B5, BK
						SST	S3N, SB, S40V
	450	(31.0)	5 - 440	(0.34-30.3)	Soft Seat - <b>SST/TFE ONLY</b>	SST	S3, S9, S36
					Metal Seated	SST	S2, S2N, S0, S1, S5, S40
Steam	400*	(27.6)*	5 - 200*	(0.34-13.8)*	Metal Seated	BRZ/BR	B1
	450	(31.0)	5 - 300	(0.34-20.7)	Metal Seated	SST	S1, S2
	450	(31.0)	5 - 440	(0.34-30.3)	Metal Seated - Opt-15 Stellite	SST	S1

\* Saturated Only

**NOTE:** For  $\Delta P = 1-5$  psid (.07 - .34 Bard), use Opt-17 piston spring.

**TABLE 2  
MAXIMUM CAPACITY – Cv  
FOR SIZING SAFETY RELIEF DEVICE  
(WITH PLUG WIDE OPEN)**

Body Size		Orifice Size			
		Standard		Opt - 12 Reduced	
in	(DN)	Size	Cv	Size	Cv
1/2"	(15)	1/2"	5	3/8"	3
3/4"	(20)	3/4"	9	1/2"	7
1"	(25)	7/8"	9	5/8"	8

**NOTE:** See footnote 1 of Table 8 for technical information on safety relief valve or rupture disc setpoint pressure.  
**METRIC CONVERSION FACTOR: Cv / 1.16 = kv**

**TABLE 3**  
**MAXIMUM ALLOWABLE PRESSURE vs. TEMPERATURE;**  
**FOR PRESSURE CONTAINMENT OF**  
**BODY, SPRING CHAMBER AND CYLINDER**  
(See Table 4 for Material Specifications)

Materials of Construction <sup>1</sup>  Description - Abbreviation Body/Spring Chamber/ Cylinder	Inlet - Cylinder				Outlet - Body & Spring Chamber <sup>3</sup>			
	Pressure		Temperature		Pressure		Temperature	
	psig	(Barg)	°F	(°C)	psig	(Barg)	°F	(°C)
CI/CI/BRZ BRZ/CI/BRZ BRZ/BRZ/BRZ	400	(27.6)	-20 to +150	(-29 to +66)	50	(3.44)	-20 to +400	(-29 to +205)
	385	(26.5)	+200	(+94)				
	365	(25.2)	+250	(+121)				
	335	(23.1)	+300	(+149)				
	300	(20.7)	+350	(+177)				
	250	(17.2)	+400	(+205)				
CI/CI/SST CS/CI/SST SST/CI/SST	450	(31.0)	-20 to +450	(-29 to +232)	50	(3.44)	-20 to +450	(-29 to +232)
CS/CS/SST SST/CS/SST SST/SST/SST	450	(31.0)	-20 to 600 <sup>2</sup>	(-29 to +315) <sup>2</sup>	50	(3.44)	-20 to +600	(-29 to +315)

<sup>1</sup> For constructions containing following materials as the body, spring chamber, or cylinder, the pressure vs. temperature limits are based upon:

Material	ASME Specification No.
BRZ	B31.3
CI	B31.3
CS	B31.3
SST	B31.3

<sup>2</sup> Requires use of Opt-46G, high temperature gasket for temperatures from +450 to +600°F (+232 to +315°C).

<sup>3</sup> Internal damage will occur; pressure containment will be maintained.

**TABLE 4**  
**MATERIAL SPECIFICATIONS OF**  
**BODY, SPRING CHAMBER AND CYLINDER**

MATERIAL	ASTM Specifications
BRZ - cast bronze	B62, Alloy 83600; 85% Cu, 5% Sn, 5% Pb, 5% Zn
CI- cast iron	A126, Class B
CS - cast carbon steel	A216, Gr. WCB
SST - cast stainless steel	A351, Gr. CF8M (cast 316 SST)

**TABLE 5  
APPLICATIONS**

Fluid	Recommended Construction	Trim Number <sup>1</sup>
Air or Inert Gases	Metal Seat & Diaphragm Composition Seat & Diaphragm Composition Seat & Metal Diaphragm Metal Seat & Composition Diaphragm	B1 BB, BK, <b>B2</b> , B3, S3N, SB, S40V B5 S2N
Oxygen <sup>2</sup>	Composition Seat & Metal Diaphragm	<b>B5</b> , S36
Liquids	Metal Seat & Diaphragm Composition Seat & Diaphragm	B1, S1 BB, BK, <b>B2</b> , B3, S3N, SB, S40V
Chemicals	Metal Seat & Composition Diaphragm Metal Seat & Diaphragm Composition Seat & Diaphragm Composition Seat & Metal Diaphragm	S5, S40 <sup>3</sup> S0 S3, S40V S9, S36
Sour Gas/Crude	Metal Seat & Composition Diaphragm	S40
Sour Gas/Crude	Composition Seat & Diaphragm	S3, S3N, S40V
Fuel Oil <sup>‡</sup>	Composition Seat & Diaphragm	BB, BK, SB, S40V
Hydrocarbon Gas or Liquids <sup>‡</sup>	Composition Seat & Diaphragm	BB, BK, S3, S3N, SB, S40V
Steam, Saturated or Superheated	Metal Seat & Diaphragm	<b>S2</b> , B1, S1
Water and Condensate, Low Temp. (32-180°F) (0-83°C)	Composition Seat & Diaphragm Metal Seat & Diaphragm	BB, BK, <b>B2</b> , B3, <b>S3</b> , S3N, SB, S40V S2N
Water and Condensate, High Temp. (180-300°F) (83-149°C)	Metal Seat & Diaphragm	<b>S1</b> , B1, S2

<sup>1</sup> S1 trim is available with stellite faced plug and valve seat (Opt. -15).

<sup>2</sup> Oxygen service requires specifying Opt-55, and using BRZ or SST body materials ONLY.

<sup>3</sup> Specify S40 trim for NACE service.

Note: Trim Designation Nos. in "boldface" are the most commonly used. Cashco, or its representatives may make recommendations or suggestions as to the suitability of certain trims for specific services. These are trims that have been used successfully in the past in similar applications. However, the user has final responsibility for materials selected.

<sup>‡</sup> In accordance with ASME B31.3 "process piping", do not use Cast Iron Body for hydrocarbon or flammable fluid service with inlet pressures greater than 150 psig (10.3 Barg) or temperatures greater than 300° F (149° C).

**TABLE 6  
BRASS TRIM MATERIAL COMBINATIONS**

Part	Brass Trim #					
	B1	B2	B3	B5	BB	BK
Diaphragm	302 SST	BC	BC	Phos. Bronze	NBR	FKM
Cylinder	Brass	Brass	Brass	Brass	Brass	Brass
Valve Seat	316 SST	Brass	Brass	Brass	Brass	Brass
Plug	416 SST	Brass	Brass	Brass	Brass	Brass
Seat Disc	None (metal)	NBR	V-TFE	V-TFE	NBR	FKM
Seat Disc Screw	None	Brass	Brass	Brass	Brass	Brass
Plug Collar	Brass	Brass	Brass	Brass	Brass	Brass
Rocker Arm Shaft	Brass	Brass	Brass	Brass	Brass	Brass
Rocker Arm	CF8M	CF8M	CF8M	CF8M	CF8M	CF8M
Pusher Plate Stud	Brass	Brass	Brass	Brass	Brass	Brass
Pusher Plate	Bronze	Bronze	Bronze	Bronze	Bronze	Bronze
Stud Collar	Brass	Brass	Brass	Brass	Brass	Brass
Cotter Pin	Brass	Brass	Brass	Brass	Brass	Brass
Nut	Brass	Brass	Brass	Brass	Brass	Brass
Temperature Range °F	-20 to +400	-20 to +180		-20 to +200	-20 to +180	-20 to +400
Temperature Range °C	-29 to +205	-29 to +83		-29 to +93	-29 to +83	-29 to +205

ABBREVIATIONS	
NBR	= Buna-N
BC	= Neoprene
EPDM	= Ethylene Propylene
TFE	= Polytetrafluoroethylene
FKM	= Fluorocarbon elastomer
V-TFE	= Virgin TFE
Phos BRZ	= Phosphor Bronze

**NOTE:** Cashco, Inc. does not recommend metal seated trim on any service where the flow will be dead ended down stream of the pressure reducing regulator.

**TABLE 7**  
**STAINLESS STEEL TRIM MATERIAL COMBINATIONS**

Part	Stainless Steel Trim#											
	S0	S1 <sup>1</sup>	S2	S2N	S3*	S3N*	S5	S9	S40V*	SB	S36	S40*
Diaphragm	TFE/ 302 SST	302 SST	302 SST	BC	BC	BC	FKM	TFE/ 302 SST	FKM	NBR	302 SST	BC
Cylinder	CF8M	CF8M	CF8M	CF8M	CF8M	CF8M	CF8M	CF8M	CF8M	CF8M	CF8M	CF8M
Valve Seat	316 SST	316 SST	316 SST	316 SST	316 SST	316 SST	316 SST	316 SST	316 SST	316 SST	316 SST	316 SST
Plug	316 SST	316 SST	416 SST	416 SST	316 SST	316 SST	416 SST	316 SST	316 SST	416 SST	316 SST	316 SST
Seat Disc	None (Metal)	None (Metal)	None (Metal)	None (Metal)	V-TFE	NBR	None (Metal)	V-TFE	FKM	NBR	V-TFE	None (Metal)
Seat Disc Screw	None	None	None	None	316 SST	316 SST	None	316 SST	316 SST	316 SST	316 SST	None
Plug Collar	316 SST	316 SST	316 SST	316 SST	316 SST	316 SST	316 SST	316 SST	316 SST	316 SST	316 SST	316 SST
Rocker Arm Shaft	316 SST	316 SST	316 SST	316 SST	316 SST	316 SST	316 SST	316 SST	316 SST	316 SST	316 SST	316 SST
Rocker Arm	CF8M	CF8M	CF8M	CF8M	CF8M	316 SST	CF8M	CF8M	CF8M	CF8M	CF8M	CF8M
Pusher Plate and Stud	CF8M	CF8M	CF8M	CF8M	CF8M	CF8M	CF8M	CF8M	CF8M	CF8M	CF8M	CF8M
Stud Collar	316 SST	316 SST	316 SST	316 SST	316 SST	316 SST	316 SST	316 SST	316 SST	316 SST	316 SST	316 SST
Cotter Pin	316 SST	316 SST	316 SST	316 SST	316 SST	316 SST	316 SST	316 SST	316 SST	316 SST	316 SST	316 SST
Nut	316 SST	316 SST	316 SST	316 SST	316 SST	316 SST	316 SST	316 SST	316 SST	316 SST	316 SST	316 SST
Temperature Range °F	-20 to 400	-20 to 600		-20 to 180			-20 to 400			-20 to 180	-20 to 400	-20 to 180
Temperature Range °C	-29 to 205	-29 to 315		-29 to 83			-29 to 205			-29 to 83	-29 to 205	-29 to 83

<sup>1</sup> Available with Stellite faced plug and valve seat (Opt-15). Includes a screwed in seat cone.

\* Use for NACE service.

**NOTE:** Cashco, Inc. does not recommend metal seated trim on any service where the flow will be dead ended down stream of the pressure reducing regulator.

**TABLE 8**  
**CONSOLIDATED PRESSURE vs. TEMPERATURE MATERIALS OPERATING LIMITS,**  
**INCLUDING TRIM AND OPTION LIMITS**

Materials	End Conn. Option No.	Trim Design. No.	Inlet Pressure		Outlet Pressure <sup>1,3</sup>		Inlet & Outlet Temperature Rg.		Limiting Portion <sup>2</sup>
			psig	(Barg)	psig	(Barg)	°F	(°C)	
BRZ/BRZ/BRZ BRZ/CI/BRZ CI/CI/BRZ	Std - NPT Opt-31 Opt-45 Opt-46G	B2, B3, BB	400	(27.6)	35	(2.4)	-20 to +150	(-29 to +66)	BRZ
			390	(26.9)	35	(2.4)	+180	(+83)	BRZ, BC, NBR
		B1	400	(27.6)	35	(2.4)	-20 to +150	(-29 to +66)	BRZ
			385	(26.6)	35	(2.4)	+200	(+94)	
			365	(25.2)	35	(2.4)	+250	(+121)	
			335	(23.1)	35	(2.4)	+300	(+149)	
			300	(20.7)	35	(2.4)	+350	(+177)	
250	(17.2)	35	(2.4)	+400	(+205)	BRZ, V-TFE			
CI/CI/SST CS/CI/SST SST/CI/SST	Std. - NPT Opt-31 Opt-32 Opt-45, Opt-46G	S2N, S3, S3N, S40, SB	450	(31.0)	40	(2.8)	-20 to +180	(-29 to +83)	BC, NBR
		S0, S1, S2 S5, S9, S36	450	(31.0)	40	(2.8)	-20 to +400	(-29 to +205)	V-TFE, FKM
	Std. NPT Opt-31, Opt-32 Opt-46G	S1, S2	450	(31.0)	40	(2.8)	-20 to +450	(-29 to +232)	CI, Std. Gasket
CS/CS/SST SST/CS/SST SST/SST/SST	Std - NPT Opt-31 Opt-32 Opt-45 Opt-46G	S2N, S3,S3N, S40,SB	450	(31.0)	40	(2.8)	-20 to +180	(-29 to +83)	BC, NBR
		S0, S5, S9, S36	450	(31.0)	40	(2.8)	-20 to +400	(-29 to +205)	V-TFE, FKM
	Std - NPT Opt-31, Opt-32 Opt-46G	S1, S2	450	(31.0)	40	(2.8)	-20 to +450	(-29 to +232)	Std. Gasket
		Std. - NPT Opt-31 Opt-46G (Req'd)	S1, S2	450	(31.0)	40	(2.8)	-20 to +600	(-29 to +315)

<sup>1</sup> See Next Page

<sup>2</sup> See Next Page

<sup>3</sup> See Next Page



**TABLE 8, Continued**  
**CONSOLIDATED PRESSURE vs. TEMPERATURE MATERIALS OPERATING LIMITS,**  
**INCLUDING TRIM AND OPTION LIMITS**

Materials	End Conn. Option No.	Trim Design. No.	Inlet Pressure		Outlet Pressure <sup>1,3</sup>		Inlet & Outlet Temperature Rg.		Limiting Portion <sup>2</sup>
			psig	(Barg)	psig	(Barg)	°F	(°C)	
CS/CI/SST CS/CS/SST	Opt-30 150# Flg. Opt-45 Opt-46G	S2N,S3,SB S3N,S40	285	(19.7)	40	(2.8)	-20 to +100	(-29 to +38)	150# Flg.
			265	(18.3)	40	(2.8)	+180	(+83)	150# Flg., BC, NBR
		S0, S5 S9, S36	285	(19.7)	40	(2.8)	-20 to +100	(-29 to +38)	150# Flg.
			260 230 200	(17.9) (15.9) (13.8)	40 40 40	(2.8) (2.8) (2.8)	+200 +300 +400	(+94) (+149) (+205)	V-TFE, FKM, 150# Flg.
	S1, S2	285 260 230 200	(19.7) (17.9) (15.9) (13.8)	40 40 40 40	(2.8) (2.8) (2.8) (2.8)	+200 +300 +400	(+94) (+149) (+205)	150# Flg. TFE Gasket, 150# Flg.	
Opt-30 150# Flg. & Opt-46G (Req'd)	S1, S2	185	(12.8)	40	(2.8)	+450	(+233)	Std. Gasket, 150# Flg., CI	
CS/CS/SST	Opt-30 150# Flg. & Opt-46G (Req'd)	S1, S2	170	(11.7)	40	(2.8)	-20 to +500	(-29 to +260)	150# Flg.
			140	(9.7)	40	(2.8)	+600	(+315)	High Temperature Gasket, 150# Flg.
SST/CI/SST SST/CS/SST SST/SST/SST	Opt-30, 150# Flg. Opt-45, Opt-46G	S2N, S3, SB S3N, S40	275	(19.0)	40	(2.8)	-20 to +100	(-29 to +38)	150# Flg.
			245	(16.9)	40	(2.8)	+180	(+83)	150# Flg., BC, NBR
		S0, S5 S9, S36	275	(19.0)	40	(2.8)	-20 to +100	(-29 to +38)	150# Flg.
			240 215 195	(16.6) (14.8) (13.4)	40 40 40	(2.8) (2.8) (2.8)	+200 +300 +400	(+94) (+149) (+205)	V-TFE, FKM, 150# Flg.
	S1, S2	275 240 215 195 180	(19.0) (16.6) (14.8) (13.4) (12.4)	40 40 40 40 40	(2.8) (2.8) (2.8) (2.8) (2.8)	+200 +300 +400 +450	(+94) (+149) (+205) (+233)	150# Flg. TFE Gasket, 150# Flg. Std. Gasket, 150# Flg., CI	
SST/CS/SST SST/SST/SST	Opt-30 150# Flg. Opt-46G (Req'd.)	S1, S2	170 140	(11.7) (9.7)	40 40	(2.8) (2.8)	-20 to +500 +600	(-29 to +260) (+315)	150# Flg. 150# Flg.. High Tempera- ture Gasket
CS/CI/SST CS/CS/SST SST/CS/SST SST/SST/SST	Opt-30, 3-- Flg., Opt-45, Opt-46G	S2N,S3,SB, S3N,S40	450	(31.0)	40	(2.8)	-20 to +180	(-29 to +83)	BC, NBR
		S0, S5, S0, S36	450	(31.0)	40	(2.8)	-20 to +400	(-29 to +205)	V-TFE, FKM
		S1, S2	450	(31.0)	40	(2.8)	-20 to +400	(-29 to +205)	TFE Gasket
	Opt-30, 300# Flg., Opt-46G						+450	(+232)	Std. Gasket, CI
CS/CS/SST SST/CS/SST SST/SST/SST	Opt-30 300# Flg. & Opt-46G (Req'd.)	S1, S2	450	(31.0)	40	(2.8) (2.8) (2.8)	-20 to +600	(-29 to +315)	High Temperature Gasket

<sup>1</sup> Indicated outlet pressure limits are those to contain overpressure conditions; such overpressure should not cause internals damage. It is recommended that pressure safety devices – safety relief valve or rupture disc – have their setpoint relief pressures at 120% of the UVRS (UVRS = “Upper Value of Range Spring”). Example: For a 12–30 psig (.83–2.1 Barg) range spring, the safety device should be set to relieve at 120% x 30 psig = 36 psig (2.5 Barg).

<sup>2</sup> For all material/trim combinations, the 1000LP diaphragm pusher plate and rocker arm mechanical internals design are the limiting factors.

<sup>3</sup> Pressure integrity will be maintained up to 150 psig (10.3 Barg). Up to 40 psig (2.8 Barg), no internals damage will occur; above 45 psig (3.1 Barg) internals damage will occur.

**TABLE 9  
Cv – FLOW CAPACITY**

**FULL PORT – COMPOSITION DIAPHRAGM**

Based on 400 psid (27.6 Bard) max pressure drop limit for composition seat,  
and on 450 psid (31.0 Bard) for metal seat.

$(F_L = 0.93)$

<b>COMPOSITION DIAPHRAGM - SIZE 1/2" (DN15) - FULL PORT</b>										
Outlet Pressure		Max Inlet Pressure				Cv @ % DROOP			Range Spring	
		Metal Seated		Composition Seated						
psig	(Barg)	psig	(Barg)	psig	(Barg)	10%	20%	30%	psig	(Barg)
1	(.07)	80	(5.5)	80	(5.5)	0.51	0.89	1.31	1-5	(.07-.34)
2	(.14)	166	(11.5)	166	(11.5)	0.67	1.23	1.64	1-5	(.07-.34)
3	(.21)	252	(17.4)	252	(17.4)	0.83	1.47	1.93	1-5	(.07-.34)
4	(.28)	342	(23.6)	342	(23.6)	0.84	1.48	1.95	1-5	(.07-.34)
5	(.34)	339	(23.4)	339	(23.4)	1.14	2.04	2.78	4-15	(.28-1.0)
7.5	(.52)	450	(31.0)	408	(28.1)	1.43	2.25	2.96	4-15	(.28-1.0)
10	(.69)	450	(31.0)	410	(28.3)	1.59	2.38	3.09	4-15	(.28-1.0)
15	(1.0)	450	(31.0)	415	(28.6)	1.62	2.50	3.26	12-30	(.83-2.1)
20	(1.4)	450	(31.0)	420	(29.0)	1.64	2.62	3.50	12-30	(.83-2.1)
25	(1.7)	450	(31.0)	425	(29.3)	1.79	2.72	3.50	12-30	(.83-2.1)
30	(2.1)	450	(31.0)	430	(29.7)	1.88	2.87	3.50	12-30	(.83-2.1)

<b>COMPOSITION DIAPHRAGM - SIZE 3/4" (DN20) - FULL PORT</b>										
Outlet Pressure		Max Inlet Pressure				Cv @ % DROOP			Range Spring	
		Metal Seated		Composition Seated						
psig	(Barg)	psig	(Barg)	psig	(Barg)	10%	20%	30%	psig	(Barg)
1	(.07)	46	(3.2)	46	(3.2)	2.10	3.08	3.91	1-5	(.07-.34)
2	(.14)	100	(6.9)	100	(6.9)	2.17	3.21	4.10	1-5	(.07-.34)
3	(.21)	161	(11.1)	161	(11.1)	2.29	3.40	4.42	1-5	(.07-.34)
4	(.28)	223	(15.4)	223	(15.4)	2.47	3.74	4.94	1-5	(.07-.34)
5	(.34)	243	(19.8)	243	(16.8)	2.70	4.81	5.00	4-15	(.28-1.0)
7.5	(.52)	406	(28.0)	406	(28.0)	2.81	4.46	5.00	4-15	(.28-1.0)
10	(.69)	450	(31.0)	410	(28.3)	2.93	4.70	5.00	4-15	(.28-1.0)
15	(1.0)	450	(31.0)	415	(28.6)	2.98	4.83	5.00	12-30	(.83-2.1)
20	(1.4)	450	(31.0)	420	(29.0)	3.19	5.00	5.00	12-30	(.83-2.1)
25	(1.7)	450	(31.0)	425	(29.3)	3.38	5.00	5.00	12-30	(.83-2.1)
30	(2.1)	450	(31.0)	430	(29.7)	3.56	5.00	5.00	12-30	(.83-2.1)

<b>COMPOSITION DIAPHRAGM - SIZE 1" (DN25) - FULL PORT</b>										
Outlet Pressure		Max Inlet Pressure				Cv @ % DROOP			Range Spring	
		Metal Seated		Composition Seated						
psig	(Barg)	psig	(Barg)	psig	(Barg)	10%	20%	30%	psig	(Barg)
1	(.07)	25	(1.7)	25	(1.7)	2.30	3.92	4.87	1-5	(.07-.34)
2	(.14)	70	(4.8)	70	(4.8)	2.57	4.19	4.90	1-5	(.07-.34)
3	(.21)	114	(7.9)	114	(7.9)	2.86	4.30	5.19	1-5	(.07-.34)
4	(.28)	157	(10.8)	157	(10.8)	3.10	4.42	5.38	1-5	(.07-.34)
5	(.34)	160	(11.0)	160	(11.0)	3.50	4.86	5.90	4-15	(.28-1.0)
7.5	(.52)	276	(19.0)	276	(19.0)	3.64	5.00	5.98	4-15	(.28-1.0)
10	(.69)	390	(26.9)	390	(26.9)	3.78	5.14	6.00	4-15	(.28-1.0)
15	(1.0)	404	(27.9)	404	(27.9)	3.80	5.16	6.00	12-30	(.83-2.1)
20	(1.4)	450	(31.0)	420	(29.0)	3.79	5.47	6.00	12-30	(.83-2.1)
25	(1.7)	450	(31.0)	425	(29.3)	4.10	5.75	6.00	12-30	(.83-2.1)
30	(2.1)	450	(31.0)	430	(29.7)	4.27	6.00	6.00	12-30	(.83-2.1)

Metric Conversion Factor:  $C_v / 1.16 = k_v$

**TABLE 10**  
**Cv – FLOW CAPACITY**

**OPT -12, 1-STEP REDUCED PORT – COMPOSITION DIAPHRAGM**

Based on 400 psid (27.6 Bard) max pressure drop limit for composition seat,  
and on 450 psid (31.0 Bard) for metal seat.  
( $F_L = 0.93$ )

<b>COMPOSITION DIAPHRAGM - SIZE 1/2" (DN15) - 1-STEP REDUCED PORT</b>										
Outlet Pressure		Max Inlet Pressure				Cv @ % DROOP			Range Spring	
		Metal Seated		Composition Seated						
psig	(Barg)	psig	(Barg)	psig	(Barg)	10%	20%	30%	psig	(Barg)
1	(.07)	89	(6.1)	133	(9.2)	0.37	0.66	0.97	1-5	(.07-.34)
2	(.14)	183	(12.6)	273	(18.8)	0.50	0.99	1.47	1-5	(.07-.34)
3	(.21)	280	(19.3)	403	(27.8)	0.61	1.16	1.68	1-5	(.07-.34)
4	(.28)	377	(26.0)	404	(27.9)	0.69	1.35	1.83	1-5	(.07-.34)
5	(.34)	380	(26.2)	405	(27.9)	1.00	1.78	1.98	4-15	(.28-1.0)
7.5	(.52)	450	(31.0)	408	(28.1)	1.07	1.88	2.02	4-15	(.28-1.0)
10	(.69)	450	(31.0)	410	(28.3)	1.18	1.89	2.03	4-15	(.28-1.0)
15	(1.0)	450	(31.0)	415	(28.6)	1.32	1.94	2.04	12-30	(.83-2.1)
20	(1.4)	450	(31.0)	420	(29.0)	1.37	1.98	2.04	12-30	(.83-2.1)
25	(1.7)	450	(31.0)	425	(29.3)	1.43	2.01	2.04	12-30	(.83-2.1)
30	(2.1)	450	(31.0)	430	(29.7)	1.52	2.04	2.04	12-30	(.83-2.1)

<b>COMPOSITION DIAPHRAGM - SIZE 3/4" (DN20) - 1-STEP REDUCED PORT</b>										
Outlet Pressure		Max Inlet Pressure				Cv @ % DROOP			Range Spring	
		Metal Seated		Composition Seated						
psig	(Barg)	psig	(Barg)	psig	(Barg)	10%	20%	30%	psig	(Barg)
1	(.07)	47	(3.2)	73	(5.0)	0.85	1.57	2.10	1-5	(.07-.34)
2	(.14)	126	(8.7)	197	(13.6)	0.97	1.71	2.18	1-5	(.07-.34)
3	(.21)	206	(14.2)	322	(22.2)	1.08	1.83	2.26	1-5	(.07-.34)
4	(.28)	283	(19.5)	404	(27.9)	1.19	2.01	2.42	1-5	(.07-.34)
5	(.34)	308	(21.3)	405	(27.9)	1.38	2.27	2.50	4-15	(.28-1.0)
7.5	(.52)	450	(31.0)	408	(28.1)	1.58	2.36	2.50	4-15	(.28-1.0)
10	(.69)	450	(31.0)	410	(28.3)	1.63	2.44	2.50	4-15	(.28-1.0)
15	(1.0)	450	(31.0)	415	(28.6)	1.57	2.38	2.50	12-30	(.83-2.1)
20	(1.4)	450	(31.0)	420	(29.0)	1.73	2.50	2.50	12-30	(.83-2.1)
25	(1.7)	450	(31.0)	425	(29.3)	1.84	2.50	2.50	12-30	(.83-2.1)
30	(2.1)	450	(31.0)	430	(29.7)	2.00	2.50	2.50	12-30	(.83-2.1)

<b>COMPOSITION DIAPHRAGM - SIZE 1" (DN15) - 1-STEP REDUCED PORT</b>										
Outlet Pressure		Max Inlet Pressure				Cv @ % DROOP			Range Spring	
		Metal Seated		Composition Seated						
psig	(Barg)	psig	(Barg)	psig	(Barg)	10%	20%	30%	psig	(Barg)
1	(.07)	33	(2.3)	49	(3.4)	1.15	2.51	3.50	1-5	(.07-.34)
2	(.14)	92	(6.3)	137	(9.4)	1.25	2.70	3.62	1-5	(.07-.34)
3	(.21)	150	(10.3)	223	(15.4)	1.39	2.95	3.80	1-5	(.07-.34)
4	(.28)	208	(14.3)	310	(21.4)	1.50	3.15	3.91	1-5	(.07-.34)
5	(.34)	212	(14.6)	316	(21.8)	1.91	3.66	4.10	4-15	(.28-1.0)
7.5	(.52)	364	(25.1)	408	(28.1)	2.05	3.74	4.10	4-15	(.28-1.0)
10	(.69)	450	(31.0)	410	(28.3)	2.12	3.81	4.10	4-15	(.28-1.0)
15	(1.0)	450	(31.0)	415	(28.6)	2.10	3.76	4.10	12-30	(.83-2.1)
20	(1.4)	450	(31.0)	420	(29.0)	2.33	3.89	4.10	12-30	(.83-2.1)
25	(1.7)	450	(31.0)	425	(29.3)	2.63	4.00	4.10	12-30	(.83-2.1)
30	(2.1)	450	(31.0)	430	(29.7)	3.00	4.10	4.10	12-30	(.83-2.1)

**Metric Conversion Factor: Cv / 1.16 = kv**

**TABLE 11**  
**Cv – FLOW CAPACITY**

**FULL PORT – METAL DIAPHRAGM**

Based on 400 psid (27.6 Bard) max pressure drop limit for composition seat,  
and on 450 psid (31.0 Bard) for metal seat.

$(F_L = 0.93)$

<b>METAL DIAPHRAGM - SIZE 1/2" (DN15) - FULL PORT</b>										
<b>Outlet Pressure</b>		<b>Max Inlet Pressure</b>				<b>Cv @ % DROOP</b>			<b>Range Spring</b>	
		<b>Metal Seated</b>		<b>Composition Seated</b>						
<b>psig</b>	<b>(Barg)</b>	<b>psig</b>	<b>(Barg)</b>	<b>psig</b>	<b>(Barg)</b>	<b>10%</b>	<b>20%</b>	<b>30%</b>	<b>psig</b>	<b>(Barg)</b>
1	(.07)	84	(5.8)	84	(5.8)	0.30	0.57	0.84	1-5	(.07-.34)
2	(.14)	172	(11.9)	172	(11.9)	0.40	0.80	1.16	1-5	(.07-.34)
3	(.21)	261	(18.0)	261	(18.0)	0.47	1.00	1.38	1-5	(.07-.34)
4	(.28)	349	(24.1)	349	(24.1)	0.63	1.17	1.58	1-5	(.07-.34)
5	(.34)	375	(25.9)	375	(25.9)	0.98	1.65	2.16	4-15	(.28-1.0)
7.5	(.52)	450	(31.0)	408	(28.1)	1.05	1.88	2.28	4-15	(.28-1.0)
10	(.69)	450	(31.0)	410	(28.3)	1.08	1.90	2.45	4-15	(.28-1.0)
15	(1.0)	450	(31.0)	415	(28.6)	1.33	2.14	2.80	12-30	(.83-2.1)
20	(1.4)	450	(31.0)	420	(29.0)	1.40	2.23	2.92	12-30	(.83-2.1)
25	(1.7)	450	(31.0)	425	(29.3)	1.50	2.37	3.09	12-30	(.83-2.1)
30	(2.1)	450	(31.0)	430	(29.7)	1.57	2.47	3.30	12-30	(.83-2.1)

<b>METAL DIAPHRAGM - SIZE 3/4" (DN20) - FULL PORT</b>										
<b>Outlet Pressure</b>		<b>Max Inlet Pressure</b>				<b>Cv @ % DROOP</b>			<b>Range Spring</b>	
		<b>Metal Seated</b>		<b>Composition Seated</b>						
<b>psig</b>	<b>(Barg)</b>	<b>psig</b>	<b>(Barg)</b>	<b>psig</b>	<b>(Barg)</b>	<b>10%</b>	<b>20%</b>	<b>30%</b>	<b>psig</b>	<b>(Barg)</b>
1	(.07)	49	(3.4)	49	(3.4)	1.18	2.20	2.81	1-5	(.07-.34)
2	(.14)	112	(7.7)	112	(7.7)	1.50	2.33	3.00	1-5	(.07-.34)
3	(.21)	175	(12.1)	175	(12.1)	1.65	2.53	3.19	1-5	(.07-.34)
4	(.28)	238	(16.4)	238	(16.4)	1.70	2.71	3.44	1-5	(.07-.34)
5	(.34)	257	(17.7)	257	(17.7)	2.19	3.35	4.40	4-15	(.28-1.0)
7.5	(.52)	414	(28.6)	408	(28.1)	2.27	3.53	4.65	4-15	(.28-1.0)
10	(.69)	450	(31.0)	410	(28.3)	2.39	3.64	4.84	4-15	(.28-1.0)
15	(1.0)	450	(31.0)	415	(28.6)	2.60	4.00	5.00	12-30	(.83-2.1)
20	(1.4)	450	(31.0)	420	(29.0)	2.75	4.29	5.00	12-30	(.83-2.1)
25	(1.7)	450	(31.0)	425	(29.3)	2.93	4.50	5.00	12-30	(.83-2.1)
30	(2.1)	450	(31.0)	430	(29.7)	3.16	5.00	5.00	12-30	(.83-2.1)

<b>METAL DIAPHRAGM - SIZE 1" (DN25) - FULL PORT</b>										
<b>Outlet Pressure</b>		<b>Max Inlet Pressure</b>				<b>Cv @ % DROOP</b>			<b>Range Spring</b>	
		<b>Metal Seated</b>		<b>Composition Seated</b>						
<b>psig</b>	<b>(Barg)</b>	<b>psig</b>	<b>(Barg)</b>	<b>psig</b>	<b>(Barg)</b>	<b>10%</b>	<b>20%</b>	<b>30%</b>	<b>psig</b>	<b>(Barg)</b>
1	(.07)	34	(2.3)	34	(2.3)	1.39	2.76	3.74	1-5	(.07-.34)
2	(.14)	78	(5.4)	78	(5.4)	1.48	3.04	3.89	1-5	(.07-.34)
3	(.21)	123	(8.5)	123	(8.5)	1.59	3.21	4.12	1-5	(.07-.34)
4	(.28)	168	(11.6)	168	(11.6)	1.75	3.42	4.28	1-5	(.07-.34)
5	(.34)	181	(12.5)	181	(12.5)	2.64	4.22	5.15	4-15	(.28-1.0)
7.5	(.52)	293	(20.2)	293	(20.2)	2.72	4.31	5.27	4-15	(.28-1.0)
10	(.69)	405	(27.9)	405	(27.9)	2.83	4.40	5.40	4-15	(.28-1.0)
15	(1.0)	444	(30.6)	415	(28.6)	3.12	4.59	5.73	12-30	(.83-2.1)
20	(1.4)	450	(31.0)	420	(29.0)	3.38	4.86	6.00	12-30	(.83-2.1)
25	(1.7)	450	(31.0)	425	(29.3)	3.60	5.10	6.00	12-30	(.83-2.1)
30	(2.1)	450	(31.0)	430	(29.7)	3.89	5.50	6.00	12-30	(.83-2.1)

**Metric Conversion Factor: Cv / 1.16 = kv**

**TABLE 12  
Cv – FLOW CAPACITY**

**OPT -12, 1-STEP REDUCED PORT – METAL DIAPHRAGM**

Based on 400 psid (27.6 Bard) max pressure drop limit for composition seat,  
and on 450 psid (31.0 Bard) for metal seat.

$(F_L = 0.93)$

METAL DIAPHRAGM - SIZE 1/2" (DN15) - 1-STEP REDUCED PORT										
Outlet Pressure		Max Inlet Pressure				Cv @ % DROOP			Range Spring	
		Metal Seated		Composition Seated						
psig	(Barg)	psig	(Barg)	psig	(Barg)	10%	20%	30%	psig	(Barg)
1	(.07)	93	(6.4)	140	(9.6)	0.23	0.43	0.61	1-5	(.07-.34)
2	(.14)	190	(13.1)	284	(19.6)	0.30	0.57	0.89	1-5	(.07-.34)
3	(.21)	289	(19.9)	403	(27.8)	0.37	0.69	1.07	1-5	(.07-.34)
4	(.28)	387	(26.7)	404	(27.9)	0.47	0.84	1.28	1-5	(.07-.34)
5	(.34)	418	(28.8)	405	(27.9)	0.70	1.35	1.83	4-15	(.28-1.0)
7.5	(.52)	450	(31.0)	408	(28.1)	0.79	1.50	1.93	4-15	(.28-1.0)
10	(.69)	450	(31.0)	410	(28.3)	0.87	1.58	1.95	4-15	(.28-1.0)
15	(1.0)	450	(31.0)	415	(28.6)	1.00	1.81	2.01	12-30	(.83-2.1)
20	(1.4)	450	(31.0)	420	(29.0)	1.08	1.88	2.04	12-30	(.83-2.1)
25	(1.7)	450	(31.0)	425	(29.3)	1.16	1.92	2.04	12-30	(.83-2.1)
30	(2.1)	450	(31.0)	430	(29.7)	1.27	1.95	2.04	12-30	(.83-2.1)

METAL DIAPHRAGM - SIZE 3/4" (DN20) - 1-STEP REDUCED PORT										
Outlet Pressure		Max Inlet Pressure				Cv @ % DROOP			Range Spring	
		Metal Seated		Composition Seated						
psig	(Barg)	psig	(Barg)	psig	(Barg)	10%	20%	30%	psig	(Barg)
1	(.07)	61	(4.2)	96	(6.6)	0.30	0.57	0.84	1-5	(.07-.34)
2	(.14)	142	(9.8)	222	(15.3)	0.40	0.80	1.16	1-5	(.07-.34)
3	(.21)	223	(15.4)	348	(24.0)	0.47	1.00	1.38	1-5	(.07-.34)
4	(.28)	302	(20.8)	404	(27.9)	0.63	1.17	1.58	1-5	(.07-.34)
5	(.34)	326	(22.5)	405	(27.9)	0.98	1.65	2.16	4-15	(.28-1.0)
7.5	(.52)	450	(31.0)	408	(28.1)	1.05	1.88	2.28	4-15	(.28-1.0)
10	(.69)	450	(31.0)	410	(28.3)	1.08	1.90	2.45	4-15	(.28-1.0)
15	(1.0)	450	(31.0)	415	(28.6)	1.33	2.14	2.80	12-30	(.83-2.1)
20	(1.4)	450	(31.0)	420	(29.0)	1.40	2.23	2.92	12-30	(.83-2.1)
25	(1.7)	450	(31.0)	425	(29.3)	1.50	2.37	3.09	12-30	(.83-2.1)
30	(2.1)	450	(31.0)	430	(29.7)	1.57	2.47	3.30	12-30	(.83-2.1)

METAL DIAPHRAGM - SIZE 1" (DN25) - 1-STEP REDUCED PORT										
Outlet Pressure		Max Inlet Pressure				Cv @ % DROOP			Range Spring	
		Metal Seated		Composition Seated						
psig	(Barg)	psig	(Barg)	psig	(Barg)	10%	20%	30%	psig	(Barg)
1	(.07)	45	(3.1)	66	(4.6)	0.70	1.41	2.20	1-5	(.07-.34)
2	(.14)	104	(7.2)	155	(10.7)	0.75	1.55	2.36	1-5	(.07-.34)
3	(.21)	163	(11.2)	243	(16.8)	0.81	1.70	2.63	1-5	(.07-.34)
4	(.28)	222	(15.3)	331	(22.8)	0.92	1.85	2.88	1-5	(.07-.34)
5	(.34)	240	(16.5)	357	(24.6)	1.32	2.77	3.75	4-15	(.28-1.0)
7.5	(.52)	389	(26.8)	408	(28.1)	1.39	2.90	3.85	4-15	(.28-1.0)
10	(.69)	450	(31.0)	410	(28.3)	1.45	3.03	3.89	4-15	(.28-1.0)
15	(1.0)	450	(31.0)	415	(28.6)	1.65	3.30	4.01	12-30	(.83-2.1)
20	(1.4)	450	(31.0)	420	(29.0)	1.83	3.57	4.10	12-30	(.83-2.1)
25	(1.7)	450	(31.0)	425	(29.3)	2.10	3.75	4.12	12-30	(.83-2.1)
30	(2.1)	450	(31.0)	430	(29.7)	2.35	3.95	4.12	12-30	(.83-2.1)

**Metric Conversion Factor: Cv / 1.16 = kv**

**TABLE 13**  
**COMPRESSED AIR CAPACITY – SCFH**  
S.G. = 1.0      T = 60°F (15.9°C)      F<sub>L</sub> = 0.93

**FULL PORT – COMPOSITION DIAPHRAGM & SEAT**

Outlet Pressure P2, psig	Inlet Pressure P1, psig	Pressure Drop psi	SCFH @ 1/2" Body Size			SCFH @ 3/4" Body Size			SCFH @ 1" Body Size		
			DROOP			DROOP			DROOP		
			10%	20%	30%	10%	20%	30%	10%	20%	30%
1	25	24	600	1100	1700	2600	3900	4900	HI P1	HI P1	6100
	50	49	1100	1800	2700	HI P1	HI P1	HI P1	HI P1	HI P1	HI P1
	75	74	1500	2500	3700	HI P1	HI P1	HI P1	HI P1	HI P1	HI P1
	100	99	HI P1	HI P1	HI P1	HI P1	HI P1	HI P1	HI P1	HI P1	HI P1
2	25	23	800	5300	2100	2700	4000	5200	3200	5300	6200
	50	48	1400	8700	3400	4500	6600	8400	5300	8600	10100
	75	73	1900	SONIC	4700	6200	9200	11700	HI P1	5400	HI P1
	100	98	2400	SONIC	6000	7900	11700	15000	HI P1	8900	HI P1
	125	123	3000	SONIC	7300	HI P1	HI P1	HI P1	HI P1	12300	HI P1
	150	148	3500	SONIC	8600	HI P1	HI P1	HI P1	HI P1	15700	HI P1
	175	173	HI P1	HI P1	HI P1	HI P1	HI P1	HI P1	HI P1	HI P1	HI P1
3	25	22	1000	1800	2400	2900	4300	5500	3600	5400	6500
	50	47	1700	3000	4000	4700	7000	9100	5900	8900	10700
	75	72	2400	4200	5500	6500	9700	12600	8200	12300	14800
	100	97	3000	5400	7000	8400	12400	16100	10400	15700	19000
	125	122	3700	6500	8600	10200	15100	SONIC	HI P1	HI P1	HI P1
	150	147	4400	7700	10100	12000	17800	SONIC	HI P1	HI P1	HI P1
	175	172	5000	8900	SONIC	HI P1	HI P1	HI P1	HI P1	HI P1	HI P1
	200	197	5700	10100	SONIC	HI P1	HI P1	HI P1	HI P1	HI P1	HI P1
	225	222	6400	SONIC	SONIC	HI P1	HI P1	HI P1	HI P1	HI P1	HI P1
	250	247	7000	SONIC	SONIC	HI P1	HI P1	HI P1	HI P1	HI P1	HI P1
	300	297	HI P1	HI P1	HI P1	HI P1	HI P1	HI P1	HI P1	HI P1	HI P1
4	25	21	1000	1800	2400	3100	4700	6200	3900	5500	6700
	50	46	1700	3000	4000	5100	7700	10200	6400	9100	11100
	75	71	2400	4200	5600	7100	10700	14100	8800	12600	15400
	100	96	3100	5400	7100	9000	13700	18000	11300	16100	19600
	125	121	3700	6600	8700	11000	16600	SONIC	13800	19700	23900
	150	146	4400	7800	10200	13000	SONIC	SONIC	16300	23200	28200
	175	171	5100	9000	SONIC	SONIC	SONIC	SONIC	HI P1	HI P1	HI P1
	200	196	5800	10100	SONIC	16900	SONIC	SONIC	HI P1	HI P1	HI P1
	225	221	6400	SONIC	SONIC	HI P1	HI P1	HI P1	HI P1	HI P1	HI P1
	250	246	7100	SONIC	SONIC	HI P1	HI P1	HI P1	HI P1	HI P1	HI P1
	300	296	8400	SONIC	HI P1	HI P1	HI P1	HI P1	HI P1	HI P1	HI P1
5	25	20	1400	2500	3400	3300	6000	6200	4300	6000	7300
	50	45	2300	4200	5700	5600	9900	10300	7200	10000	12100
	75	70	3300	5800	7900	7700	13700	14300	10000	13900	16800
	100	95	4200	7500	10200	9900	17600	18300	12800	17700	21500
	125	120	5100	9100	SONIC	12000	SONIC	SONIC	15600	21600	26300
	150	145	6000	10700	SONIC	14200	SONIC	SONIC	18400	25500	31000
	175	170	6900	SONIC	SONIC	16300	SONIC	SONIC	HI P1	HI P1	HI P1
	200	195	7800	SONIC	SONIC	18500	SONIC	SONIC	HI P1	HI P1	HI P1
	225	220	8700	SONIC	SONIC	SONIC	SONIC	SONIC	HI P1	HI P1	HI P1
	250	245	9600	SONIC	SONIC	HI P1	HI P1	HI P1	HI P1	HI P1	HI P1
	300	295	SONIC	SONIC	SONIC	HI P1	HI P1	HI P1	HI P1	HI P1	HI P1
7.5	25	17.5	1700	2700	3600	3400	5400	6100	4400	6100	7200
	50	42.5	2900	4600	6100	5800	9200	10300	7500	10300	12300
	75	67.5	4100	6400	8400	8000	12700	14300	10400	14300	17100
	100	92.5	5200	8200	10800	10300	16300	18300	13300	18300	21800
	125	117.5	6400	10000	SONIC	12500	19800	22300	16200	22300	26600
	150	142.5	7500	11800	SONIC	14800	SONIC	SONIC	19100	26200	31400
	175	167.5	8700	SONIC	SONIC	17000	SONIC	SONIC	22000	30200	36200
	200	192.5	9800	SONIC	SONIC	19200	SONIC	SONIC	24900	34200	SONIC
	225	217.5	10900	SONIC	SONIC	21500	SONIC	SONIC	27900	SONIC	SONIC
	250	242.5	12100	SONIC	SONIC	SONIC	SONIC	SONIC	30800	SONIC	SONIC
	300	292.5	SONIC	SONIC	SONIC	SONIC	SONIC	SONIC	HI P1	HI P1	HI P1
10	25	15	1900	2800	3600	3400	5500	5800	4400	6000	7000
	50	40	3300	4900	6400	6000	9700	10300	7800	10600	12300
	75	65	4500	6800	8800	8400	13400	14300	10800	14700	17100
	100	90	5800	8700	11300	10700	17200	18300	13800	18800	21900
	125	115	7100	10600	13800	13000	20900	22300	16800	22900	26700
	150	140	8300	12500	SONIC	15400	24700	SONIC	19800	27000	31500
	175	165	9600	SONIC	SONIC	17700	SONIC	SONIC	22900	31100	36300
	200	190	10900	SONIC	SONIC	20100	SONIC	SONIC	25900	35200	SONIC
	225	215	12200	SONIC	SONIC	22400	SONIC	SONIC	28900	39300	SONIC
	250	240	13400	SONIC	SONIC	24800	SONIC	SONIC	31900	SONIC	SONIC
	300	290	SONIC	SONIC	SONIC	SONIC	SONIC	SONIC	38000	SONIC	SONIC
15	25	10	1700	2600	3400	3100	5000	5200	3900	5300	6200
	50	35	3300	5100	6600	6100	9900	10200	7700	10500	12200
	75	60	4600	7100	9300	8500	13800	14300	10800	14700	17100
	100	85	5900	9100	11900	10900	17600	18300	13900	18800	21900
	125	110	7200	11100	14500	13300	21500	22300	16900	23000	26700
	150	135	8500	13100	17100	15600	25400	26200	19900	27100	31500
	175	160	9800	15100	SONIC	18000	29200	SONIC	23000	31200	36300
	200	185	11100	17100	SONIC	20400	SONIC	SONIC	26000	35300	41100
	225	210	12400	SONIC	SONIC	22800	SONIC	SONIC	29100	39500	45900
	250	235	13700	SONIC	SONIC	25200	SONIC	SONIC	32100	43600	SONIC
	300	285	16300	SONIC	SONIC	29900	SONIC	SONIC	38200	SONIC	SONIC
350	335	SONIC	SONIC	SONIC	SONIC	SONIC	SONIC	44300	SONIC	SONIC	

NOTES: See Next Page.

**TABLE 13 (Cont.)**  
**COMPRESSED AIR CAPACITY – SCFH**  
 S.G. = 1.0    T = 60°F (15.9°C)    F<sub>L</sub> = 0.93

**FULL PORT – COMPOSITION DIAPHRAGM & SEAT**

Outlet Pressure P2, psig	Inlet Pressure P1, psig	Pressure Drop	SCFH @ 1/2" Body Size			SCFH @ 3/4" Body Size			SCFH @ 1" Body Size			
			DROOP			DROOP			DROOP			
			10%	20%	30%	10%	20%	30%	10%	20%	30%	
20	25	5	1300	2100	2700	2500	3900	3900	3000	4300	4700	
	50	30	3300	5200	7000	6400	10000	10000	7600	10900	12000	
	75	55	4700	7500	10000	9100	14300	14300	10800	15600	17100	
	100	80	6000	9600	12800	11600	18300	18300	13800	20000	21900	
	125	105	7300	11700	15600	14200	22300	22300	16900	24300	26700	
	150	130	8600	13800	18400	16700	26200	26200	19900	28700	31500	
	175	155	9900	15800	SONIC	19300	30200	30200	22900	33100	36300	
	200	180	11200	17900	SONIC	21900	34200	34200	26000	37500	41100	
	225	205	12500	20000	SONIC	24400	SONIC	SONIC	29000	41900	45900	
	250	230	13900	SONIC	SONIC	27000	SONIC	SONIC	32000	46200	50700	
	300	280	16500	SONIC	SONIC	32100	SONIC	SONIC	38100	55000	SONIC	
	350	330	19100	SONIC	SONIC	SONIC	SONIC	SONIC	44200	SONIC	11500	
	25	50	25	3400	5200	6700	6500	9600	9600	7900	11000	17000
		75	50	5100	7700	9900	9600	14200	14200	11600	16300	21900
100		75	6500	9900	12800	12300	18300	18300	15000	21000	26700	
125		100	8000	12100	15600	15000	22300	22300	18200	25600	31500	
150		125	9400	14300	18400	17700	26200	26200	21500	30200	36300	
175		150	10800	16500	21200	20400	30200	30200	24800	34800	41100	
200		175	12300	18600	SONIC	23200	34200	34200	28100	39400	45900	
225		200	13700	20800	SONIC	25900	38300	38300	31400	44000	50700	
250		225	15100	SONIC	SONIC	28600	SONIC	SONIC	34700	48600	60300	
300		275	18000	SONIC	SONIC	34000	SONIC	SONIC	41200	57800	SONIC	
350		325	20900	SONIC	SONIC	39400	SONIC	SONIC	47800	SONIC	SONIC	
30		50	20	3400	5200	5300	6400	9000	9000	7700	10800	10800
		75	45	5300	8000	9800	10000	14000	14000	12000	16800	16800
		100	70	6900	10500	12800	13000	18200	18200	15600	21900	21900
	125	95	8400	12800	15600	15800	22300	22300	19000	26700	26700	
	150	120	9900	15100	18400	18700	26200	26200	22400	31500	31500	
	175	145	11400	17400	21200	21500	30200	30200	25800	36300	36300	
	200	170	12900	19700	24000	24400	34200	34200	29200	41100	41100	
	225	195	14400	22000	SONIC	27200	38300	38300	32700	45900	45900	
	250	220	15900	24300	SONIC	30100	42300	42300	36100	50700	50700	
	300	270	18900	SONIC	SONIC	35800	SONIC	SONIC	42900	60300	60300	
	350	320	21900	SONIC	SONIC	41500	SONIC	SONIC	49700	69900	69900	

- NOTES:**
1. Where "HI P1" is indicated, the inlet pressure exceeds the limit established in Table 9.
  2. Where "HI P2" is indicated, the maximum outlet pressure is exceeded.
  3. Where "SONIC" is indicated, flow will be approximately the last indicated value in the column above "SONIC". The outlet velocity with Schedule 160 pipe has reached sonic velocity of 1118 fps. Additional flow cannot be obtained, and pipeline velocity is in excess of customary pipe velocity design limits.

**Metric Conversion Factors: psi / 14.5 = Bar; SCFH / 35.31 = Sm<sup>3</sup>/Hr; SCFH / 37.32 = Nm<sup>3</sup>/Hr**

## DIMENSIONS & WEIGHTS

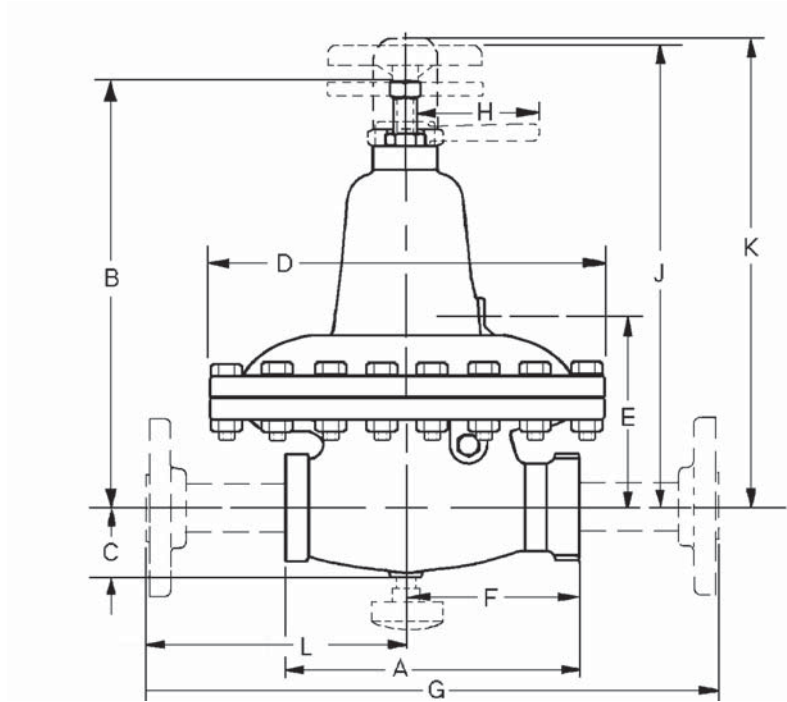

Regulator Size Inch	DIMENSIONS - ENGLISH (inches)													Approx. Weight - lbs.	
	A	B	C	D	E	F	G <sup>1</sup>	G <sup>2</sup>	G <sup>3</sup>	H	J	K	L	w/ Flanges	w/ Flanges
1/2"	5.94	10.00	1.62	9.00	4.38	3.94	10.75	11.00	13.94	3.13	11.19	11.62	5.38	27	34
3/4"	7.12	11.25	1.75	11.00	4.75	4.00	11.88	12.25	15.12	3.13	12.25	12.81	5.62	40	47
1"	7.94	11.75	2.12	11.00	5.06	4.69	13.62	14.00	15.94	3.13	12.81	13.44	6.75	45	54
(DN)	DIMENSIONS - METRIC (mm)													Approx. Weight - kg.	
(15)	151	254	41	229	111	100	273	279	354	79	284	295	137	12	15
(20)	181	286	44	279	121	102	302	311	384	79	311	325	143	18	21
(25)	202	298	54	279	129	119	346	356	405	79	325	341	171	21	24

<sup>1</sup> 150# Flange - Also available with Opt-34, special 14" (356mm) face to face dimension.

<sup>2</sup> 300# Flange - Also available with Opt-34, special 14" (356mm) face to face dimension.

<sup>3</sup> P.E. Pipe Nipples

The contents of this publication are presented for informational purposes only, and while every effort has been made to ensure their accuracy, they are not to be construed as warranties or guarantees, express or implied, regarding the products or services described herein or their use or applicability. We reserve the right to modify or improve the designs or specifications of such product at any time without notice. Cashco, Inc. does not assume responsibility for the selection, use or maintenance of any product. Responsibility for proper selection, use and maintenance of any Cashco, Inc. product remains solely with the purchaser.



# MODEL 1000LP PRODUCT CODER 03/02/16

An "X" in POS 12 followed by a 5-digit control number overrides remaining selections.



POSITION 2 - GASKETS * & Service		
Gaskets - Service	Options	CODE
Standard : TFE/Alum-Silicate - Non-Oxygen	--	B
PTFE - Primarily for Oxygen	-45	D
Carbon-Graphite - High Temp.	-46G **	G

\* Refer to Tech Bulletin for temperature limits.  
\*\* Only Available with CS or SST Body & Spring Chamber and S1 or S2 Trim

POSITION 3 - SIZE & SERVICE				
Size		Service		
		Gaseous	Liquid	Viscous (-27 Opt) *
		CODE	CODE	CODE
1/2"	(DN15)	4	J	R
3/4"	(DN20)	5	K	S
1"	(DN25)	6	L	T

\* Metal Seated B1,S0,S1,S2,S2N,S5 or S40 Trim Only.

POSITION 5 - BODY & SPRING CHAMBER MATERIALS *	
Body/Sp. Ch.	CODE
CI/CI	1
BRZ/CI	2
BRZ/BRZ	3
CS/CI	4
CS/CS	5
SST/CI	7
SST/CS	9
SST/SST	A

\* See TB Tables 1, 3, & 8 for material limitations of Design Pressure Ratings.

POSITION 6 & 7 - TRIM DESIGNATION NUMBERS			
Brass Trim **		Stainless Steel Trim	
Desig.	CODE	Desig.	CODE
B1	B1	S0	S0
B2	B2	S1	S1
B3	B3	S2	S2
B5 *	B5	S2N	SN
BB	BB	S3	S3
BK	BK	S3N	SC
		S5	S5
		S6	S6
		S9	S9
		S36	36
		S40	40
		S40V	4V
		SB	SB

\* CI or BRZ bodies only.  
\*\* Brass Trims not available with nipple & flange end connections.

POSITION 8 - Product Classification Under European "Pressure Equipment Directive"		
PRODUCT DESTINATION	HAZARD CATEGORY	CODE
Anywhere except Europe	N/A	7
European Countries *	Sound Engineering Practice (SEP)	S

\* For products to be placed in service in Europe - Ref to Directive 2014/68/EU. Forward Completed "EU" Application Recorder prior to quotation. (Without Recorder- Processing of Purchase Order will be delayed). Contact Cashco for Assistance.

POSITION 11 - RANGE SPRINGS		
Steel Range Spring		CODE
psig	(Barg)	
1-5	(.07-.34)	1
4-15	(.8-1.0)	2
12-30	(.83-2.1)	3

POSITION 10 - END CONNECTIONS	
Description	CODE
NPT - Screwed	1
-30 Opt. - 150 LB RF Flgs * (Std) (CS & SST Body Mat'l)	6
-30 Opt. - 300 LB RF Flgs * (Std) (CS & SST Body Mat'l)	7
-31 Opt. - BSP - Screwed British Standard Pipe Thread	B
-32 Opt. - SCH. 80 PE Ext. Nipples *	E
-34 Opt. - 150 LB RF Flgs. (14" F to F Dimension) *	V
-34 Opt. - 300 LB RF Flgs. (14" F to F Dimension) *	W

\* Nipples & flanges of same material as body. CS or SST bodies. Use SST trim only.

POSITION 12 - TRIM VARIATIONS			W/ -17 Opt.	
Description	Option	CODE	Option	CODE
No Special Trim Variation	--	0	--	--
Reduced Orifice (One-Step)	-12	A	-12+17	1
Integral Seat Surface (Not available with B1 Trim or NACE)	-14	C	-14+17	3
Stellited Seat S1 Trim Only	-15 *	D	-15+17	4
Reduced Orifice and Integral Seat See -14 for limitations	-12+14	E	-12+14+17	5
Reduced Orifice and Stellited Seat See -15 for limitations	-12+15 *	F	-12+15+17	6
Piston Spring	-17	H	--	--
For Special Construction Contact Cashco for Special Product Code.	SPQ		X	

\* Includes Opt-14 Integral Seat.

POSITION 14 - SPRING CHAMBER OPTIONS		
Description	Option	CODE
No Option	-	0
1/4" (DN8) NPT Vent Tap.	-25	E
SST Rain-proof Bug Vent (includes Opt-25).	-25S	H

POSITION 15 - BODY OPTIONS		
Description	Option	CODE
No Option	-	0
1/4" (DN8) NPT Drain Hole/Press. Tap.	-26	F

POSITION 16 - CERTIFICATE OPTIONS		
Description	Option	CODE
No Option	-	0
NACE Const.: CS/CS/XX, All Sizes Except DN32 Per MR0175, S3, S3N, S40, S40V Trim.	-40	J
NACE Const.:SST/CS/XX, SST/SST/XX All Sizes Except DN32 Per MR0175, S3, S3N, S40, S40V Trim.	-40SST	K
Special Cleaning: Per Cashco Spec #S-1134. W/ properly selected mat'ls. Suitable for Oxygen Service. BRZ or SST body material.	-55	M
Special Cleaning: Per Cashco Spec #S-1542.	-56	N

POSITION 13 - FEATURE OPTIONS		
Description	Option	CODE
No Option	-	0
DI Closing Cap for DI or CS Spring Chambers.	-1	1
Handwheel & Locking Lever.	-3	3

POSITION 17 - PAINT OPTIONS		
Description	Option	CODE
No Option	-	0
Epoxy Painted Per Cashco Spec #S-1547.	-95	W
Epoxy Painted Per Cashco Spec #S-1687 Offshore Applic.	-95OS	Y

Cashco, Inc.  
P.O. Box 6  
Ellsworth, KS 67439-0006  
PH (785) 472-4461  
Fax. # (785) 472-3539  
www.cashco.com  
email: sales@cashco.com  
Printed in U.S.A. 1000LP BASIC-TB

Cashco GmbH  
Handwerkerstrasse 15  
15366 Hoppegarten, Germany  
PH +49 3342 30968 0  
Fax. No. +49 3342 30968 29  
www.cashco.com  
email: germany@cashco.com

Cashco do Brasil, Ltda.  
Al.Venus, 340  
Indaiatuba - Sao Paulo, Brazil  
PH +55 11 99677 7177  
Fax. No.  
www.cashco.com  
email: brazil@cashco.com