

MODEL 3381

PRESSURE REDUCING REGULATOR

BODY SIZES 1/4" OR 3/8" (DN8 or DN10)

The Model 3381 is an inexpensive, bronze pressure reducing regulator designed to handle small to mid capacity flow rates in general service. This unit is capable of controlling outlet pressure to a level between 2 and 200 psig (.34 and 13.8 Barg).

FEATURES

- High Stability:** High mass plug allows dampening of high frequency disturbances from inlet or outlet side of regulator.
- Trim Removal:** Easily removable trim from regulator while in-line.
- Trim Selections:** Six different trim combinations for metallic or composition seated designs.

APPLICATIONS

Designed to control a wide range of fluids including industrial gases, air, oil, steam and water. See Table 1 for more information. Available for cryogenic service.

STANDARD/GENERAL SPECIFICATIONS

Body Size: 1/4" or 3/8" (DN8 or DN10) with NPT female pipe threads.

Body Material: Bronze - ASTM B62, Alloy C83600. Side inlet and side outlet.

Spring Chamber: Same specifications as body.

Diaphragms: Phosphorous Bronze, Neoprene, Fluorocarbon Elast. See Table 3.

Trims: Brass; metallic seated or composition seated. See Table 3.

Gaskets: Standard: Aramid/SBR. Applicable temperature range -20 to +400°F (-29° to +205°C). NOT SUITABLE FOR OXYGEN SERVICE.
Alternate Material: See Opt-45.

Operating Temperatures: See Tables 2 and 3.

Inlet Pressure: 800 psig maximum (55.2 Barg).

Outlet Pressure: Up to 300 psig (20.7 Barg) (includes 100 psi (6.9 Bar) pressure build when set at 200 psig (13.8 Barg) under high flow rate.

Range Springs: Standard: Epoxy coated steel.
Cryogenic: SST; See Option -5.

Spring Ranges	
psig	(Barg)
2-6	(.14-.41)
5-30	(.34-2.1)
20-80	(1.4-5.5)
70-140	(4.8-9.6)
130-200	(9.0-13.8)

Cv's / Capacities: See Tables 4, 5, 6 and 7.

OPTION SPECIFICATIONS

Option-2: HANDWHEEL. Plastic handwheel for frequent setpoint changes.

Option-4: STABILIZER. Recommended for vapor or steam service only. Stabilizer provides added guiding to maximize stability for internal trim, allowing improved pressure drop capability. Stabilizer materials are BR/TFE. For use with all trim designation numbers. **See NOTE in Table 1 for option applicability.**

Option-5: CRYOGENIC SERVICE. Includes standard body and spring chamber of bronze. All wetted internal parts are of brass or bronze, except for the piston spring which is of 302 SST. The range spring is SST, and the adjusting screw, spring button and pressure plate are brass. Standard TFE gasketing for diaphragm and pressure plate. Cleaned and packaged for oxygen service per Cashco Specification #S-1134. The spring chamber has a 1/8" (DN6) NPT female connection for purge gas plus a 1/8" (3.2 mm) drilled drain hole. Mount in horizontal piping with the adjusting screw oriented downwards. Use B0 or B5 trims. Applicable temperature range -325°F to +100°F (-198°C to +38°C).

Option-20: DOME LOADING. Spring chamber and range spring replaced by bronze dome for external pressure loading up to 100 psig (6.9 Barg); 1/4" (DN8) NPT loading connection. Maximum capacity = 0.5 C_v.

Option-22: PANEL MOUNTING. Includes a mounting nut and a handwheel. See Figure 2.

Option-45: TFE GASKETS. Primarily for oxygen service. Temperature range -20 to +400°F (-29° to +205°C).

Option-55: SPECIAL CLEANING. Cleaning per Cashco Specification #S-1134. With properly selected materials, cleanliness level suitable for Oxygen Service.

Option-56: SPECIAL CLEANING. All body materials. Cleaning per Cashco Spec. #S-1542. Cleaning identical to that of Opt-55, but not labeled for application in oxygen service. NOT suitable for Oxygen Service.

Option-85: OUTLET GAUGE TAP. 1/4" (DN8) NPT female connection on side of body, outlet end, for incorporation of gauge. Gauge not included.

TECHNICAL SPECIFICATIONS

**TABLE 1
APPLICATIONS**

Fluid	Recommended Construction	Trim Designation Number
Air, Inert or Industrial Gases	Metal Seat & Diaphragm	B0
	Composition Seat & Metal Diaphragm	B5
	Composition Seat & Diaphragm	B2, B3, B4
Cryogenic Gases or Liquids	Metal Seat & Diaphragm	B0
	Composition Seat & Metal Diaphragm	B5
Oxygen	Composition Seat & Diaphragm	B4
	Composition Seat & Metal Diaphragm	B5
	Metal Seat & Diaphragm	B0
Sour Gas, Chemicals	-----	NR
Water and Condensate	Metal Seat & Diaphragm	B0
	Composition Seat & Metal Diaphragm	B5
	Composition Seat & Diaphragm	B2, B3
Saturated Steam ¹ 150 psig & lower (10.3 Barg)	Metal Seat & Diaphragm	B0

NR: Not Recommended

¹ Pressure drops above 60 psi (4.1 Barg) can cause accelerated trim and body wear. Maximum recommended pressure drop of 120 psi (8.3 Bar).

NOTE: Opt-4 Stabilizer is for gaseous/vapor/steam service. Apply when P1abs/P2abs is greater than 2. Otherwise use standard construction.

**TABLE 2
MAXIMUM BODY
PRESSURE -TEMPERATURE RATINGS**

Materials	Inlet Pressure		Temperature	
	psig	(Barg)	°F	°C
BRZ Body	500	(34.5)	-20 to +400	(-29 to +205)
	600	(41.4)	-20 to +350	(-29 to +177)
	800	(55.2)	-20 to +150	(-29 to +65)
BRZ Body (Opt-5)	800	(55.2)	-325 to +100	(-198 to +38)

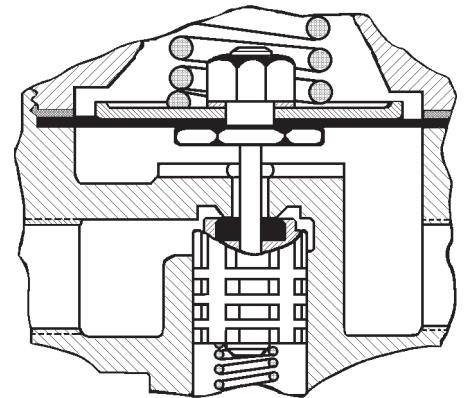

Figure 1: Composition Seat Design

**TABLE 3
BRASS TRIM MATERIAL COMBINATIONS**

Part	Brass Trim Designation Number					
	B0	B2	B3	B4	B5	BB (Fuel-Oils)
Diaphragm	Phos. Bronze	BC	BC	FKM	Phos. Bronze	NBR
Valve Piston	Brass	Brass	Brass	Brass	Brass	Brass
Valve Seat ¹	Brass	NBR	TFE	TFE	TFE	Brass
Valve Spring	302 SST	302 SST	302 SST	302 SST	302 SST	302 SST
Pusher Plate	Brass	Brass	Brass	Brass	Brass	Brass
Body Cap	Brass	Brass	Brass	Brass	Brass	Brass
Temperature Range	-325 to +200°F (-198 to 93°C)	-20 to +180°F (-29 to 82.6°C)	-20 to +180°F (-29 to 82.6°C)	-20 to +400°F (-29 to +205°C)	-325 to +200°F (-198 to +93°C)	-20 to +180°F (-29 to +83°C)

¹ The fixed portion of the seat is integral to the body. Indicated seat is the moving portion, and is attached or integral with the piston.

NOTE: Cashco, Inc. does not recommend metal seated trim on any service where the flow will be dead ended down stream of the pressure reducing regulator.

BC = Neoprene, FKM = Fluorocarbon Elastomer, NBR = Buna-N, TFE = Polytetrafluoroethylene

TABLE 4
CAPACITY - C_v (F_L = 0.95)
1/4" or 3/8" (DN8 or DN10) Sizes

Outlet (P ₂) Pressure psig	METAL DIAPHRAGM			COMPOSITION DIAPHRAGM		
	% DROOP			% DROOP		
	10%	20%	30%	10%	20%	30%
10	.05	.09	.15	.13	.22	.35
25	.13	.24	.33	.35	.47	.50
50	.07	.15	.22	.35	.47	.50
75	.12	.23	.32	.45	.50	.50
100	.11	.21	.30	.39	.49	.50
125	.13	.24	.33	.42	.50	.50
150	.10	.19	.28	.38	.48	.50
200	.11	.21	.30	.35	.47	.50

TABLE 5
WATER CAPACITY - GPM
S.G. = 1.0 T = 60°F F_L = 0.95
All Sizes - Composition Diaphragm Only

Outlet Flowing Pressure psig	Inlet Pressure psig	1/4" (DN8) Size			3/8" (DN10) Size		
		% DROOP			% DROOP		
		10%	20%	30%	10%	20%	30%
5	50	0.9	1.5	2.3	0.9	1.5	2.3
	75	1.1	1.8	2.9	1.1	1.8	2.9
	100	1.3	2.1	HI VEL	1.3	2.1	3.4
	125	1.4	2.4	HI VEL	1.4	2.4	3.8
	150	1.6	2.6	HI VEL	1.6	2.6	HI VEL
	175	1.7	2.9	HI VEL	1.7	2.9	HI VEL
10	200	1.8	3.1	HI VEL	1.8	3.1	HI VEL
	50	2.2	3.0	3.2	2.2	3.0	3.2
	75	2.8	HI VEL	HI VEL	2.8	3.8	4.0
	100	HI VEL	HI VEL	HI VEL	3.3	HI VEL	HI VEL
	125	HI VEL	HI VEL	HI VEL	3.8	HI VEL	HI VEL
15	150	HI VEL	HI VEL	HI VEL	HI VEL	HI VEL	HI VEL
	50	2.1	2.8	3.0	2.1	2.8	3.0
	75	2.7	HI VEL	HI VEL	2.7	3.6	3.9
	100	3.2	HI VEL	HI VEL	3.2	HI VEL	HI VEL
25	125	HI VEL	HI VEL	HI VEL	3.7	HI VEL	HI VEL
	150	HI VEL	HI VEL	HI VEL	HI VEL	HI VEL	HI VEL
	50	2.3	2.5	2.5	2.3	2.5	2.5
	75	3.2	HI VEL	HI VEL	3.2	3.5	3.5
35	100	HI VEL	HI VEL	HI VEL	3.9	HI VEL	HI VEL
	125	HI VEL	HI VEL	HI VEL	HI VEL	HI VEL	HI VEL
	50	1.5	1.9	1.9	1.5	1.9	1.9
	75	2.5	3.1	3.2	2.5	3.1	3.2
	100	3.1	HI VEL	HI VEL	3.1	4.0	4.0
50	125	HI VEL	HI VEL	HI VEL	3.7	HI VEL	HI VEL
	150	HI VEL	HI VEL	HI VEL	HI VEL	HI VEL	HI VEL
	75	1.9	2.4	2.5	1.9	2.4	2.5
	100	2.7	HI VEL	HI VEL	2.7	3.4	3.5
75	125	HI VEL	HI VEL	HI VEL	3.3	HI VEL	HI VEL
	150	HI VEL	HI VEL	HI VEL	3.8	HI VEL	HI VEL
	175	HI VEL	HI VEL	HI VEL	HI VEL	HI VEL	HI VEL
	100	1.8	2.4	2.5	1.8	2.4	2.5
100	125	2.5	HI VEL	HI VEL	2.5	3.3	3.5
	150	3.0	HI VEL	HI VEL	3.0	HI VEL	HI VEL
	175	HI VEL	HI VEL	HI VEL	3.5	HI VEL	HI VEL
	200	HI VEL	HI VEL	HI VEL	4.0	HI VEL	HI VEL
125	125	2.0	2.5	2.5	2.0	2.5	2.5
	150	2.8	HI VEL	HI VEL	2.8	3.5	3.5
	175	HI VEL	HI VEL	HI VEL	3.5	HI VEL	HI VEL
	200	HI VEL	HI VEL	HI VEL	4.0	HI VEL	HI VEL

NOTE: Where "HI VEL" is indicated, the flow has reached or exceeded the velocities to the right based on Schedule 40 pipe.

METRIC CONVERSION FACTORS: psig / 14.5 = Barg; GPM x 3.785 = LPM

SIZE	MAX. VEL
1/4" (DN8)	10 fps
3/8" (DN10)	12.5 fps

**TABLE 6
AIR CAPACITY - SCFH**

S.G. = 1.0 T = 60°F F_v = 0.95

All Sizes - **Composition Diaphragm Only**

Outlet Flowing Pressure psig	Inlet Pressure psig	1/4" and 3/8" (DN8 and DN10) Sizes		
		10% DROOP	20% DROOP	30% DROOP
5	25	100	200	300
	50	200	400	600
	75	300	600	900
	100	500	800	1200
	125	600	1000	1500
	150	700	1200	1900
	175	800	1400	2200
	200	900	1600	2500
10	250	1200	2000	3100
	25	300	400	400
	50	600	800	900
	75	900	1200	1300
	100	1200	1700	1800
	125	1500	2100	2200
	150	1900	2500	2700
	175	2200	2900	3100
15	200	2500	3300	3500
	250	3100	4200	4400
	25	300	400	400
	50	600	800	900
	75	900	1200	1300
	100	1200	1700	1800
	125	1500	2100	2200
	150	1900	2500	2700
25	175	2200	2900	3100
	200	2500	3300	3500
	250	3100	4200	4400
	50	700	800	800
	75	1200	1300	1300
	100	1600	1800	1800
	125	2000	2200	2200
	150	2400	2700	2700
35	175	2800	3100	3100
	200	3200	3500	3500
	250	4000	4400	4400
	50	600	700	700
	75	1000	1200	1300
	100	1400	1700	1700
	125	1700	2200	2200
	150	2100	2600	2700
50	175	2400	3000	3100
	200	2800	3500	3500
	250	3500	4300	4400
	75	800	1100	1100
	100	1300	1600	1700
	125	1600	2100	2200
	150	2000	2500	2600
	175	2300	3000	3100
75	200	2700	3400	3500
	250	3400	4300	4400
	100	900	1300	1300
	125	1400	1800	2000
	150	1800	2400	2500
	175	2100	2800	3000
	200	2400	3300	3500
	250	3100	4100	4400
100	125	1200	1500	1500
	150	1800	2200	2200
	175	2200	2700	2800
	200	2700	3300	3300
	250	3500	4200	4300
	175	1600	1900	1900
150	200	2200	2700	2700
	250	3300	3900	3900
	300	4200	5000	5000
	350	5000	6000	6000
	400	5900	7000	7000
	250	2100	2900	3100
200	300	3100	4200	4500
	350	3900	5300	5600
	400	4700	6400	6700

METRIC CONVERSION FACTORS: psig / 14.5 = Barg; SCFH / 35.31 = Sm³/Hr; SCFH / 37.32 = Nm³/Hr

TABLE 7
STEAM - LBS/HR

S.G. = Actual T = Saturated $F_L = 0.95$

All Sizes - Metal Diaphragm Only

Outlet Flowing Pressure psig	Inlet Pressure psig	1/4" and 3/8" (DN8 and DN10) Sizes		
		10% Droop	20% Droop	30% Droop
5	25	2	3	5
	50	3	6	9
	75	5	8	13
	100	6	10	16
10	25	4	5	8
	50	7	8	14
	75	9	12	20
	100	12	15	25
15	125	15	19	31
	25	4	10	14
	50	8	19	28
	75	12	27	39
25	100	15	35	50
	125	19	43	62
	50	13	25	30
	75	20	38	46
35	100	26	49	59
	125	31	60	72
	150	37	71	85
	50	6	10	15
50	75	10	17	26
	100	14	23	35
	125	17	29	43
	150	20	34	51
75	75	10	21	30
	100	14	31	44
	125	18	40	56
	150	22	47	67
100	100	17	32	45
	125	24	46	65
	150	30	58	82
	125	16	36	50
	150	23	51	72

METRIC CONVERSION FACTORS: psig / 14.5 = Barg; LBS/Hr x 0.4536 = KG/Hr

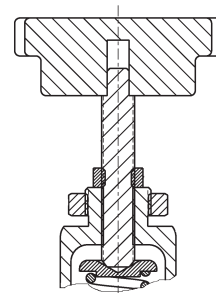
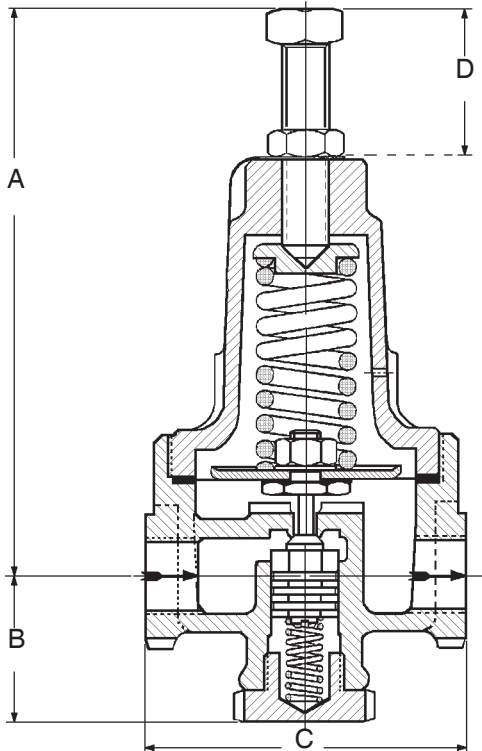

Figure 2: Option -22 Panel Mounting (handwheel portion is same as Option -2 Handwheel).

Spring Chamber Thread 3/4"-16-UNF-2A

DIMENSIONS AND WEIGHTS

ENGLISH UNITS (Inches)					
Body Size 1/4" & 3/8"	A	B	C	D	Shipping Weight
Standard	5.12	1.43	2.50	—	3 lbs.
-2 (Handwheel)	5.56	1.43	2.50	—	
-20 (Dome Load)	2.00	1.43	2.50	—	
-22 (Panel Mount)	5.25	1.43	2.50	2.25	
METRIC UNITS (mm)					
Body Size DN8 & DN10	A	B	C	D	Shipping Weight
Standard	130	36	63	—	1.36 kgs.
-2 (Handwheel)	141	36	63	—	
-20 (Dome Load)	51	36	63	—	
-22 (Panel Mount)	133	36	63	57	

NOTES

The contents of this publication are presented for informational purposes only, and while every effort has been made to ensure their accuracy, they are not to be construed as warranties or guarantees, express or implied, regarding the products or services described herein or their use or applicability. We reserve the right to modify or improve the designs or specifications of such product at any time without notice.
Cashco, Inc. does not assume responsibility for the selection, use or maintenance of any product. Responsibility for proper selection, use and maintenance of any Cashco, Inc. product remains solely with the purchaser.

MODEL 3381 PRODUCT CODER 03/04/16

An "X" in POS 12 followed by a 5-digit control number overrides remaining selections.



POSITION 2 - GASKET * & SERVICE			
Service	Gaskets	Options	CODE
Basic (Above -20°F (-29°C))	Non-Oxygen	Std: Aramid/SBR	— B
	Primarily for Oxygen	TFE	-45 D
Cryogenic -325 to +100°F (-198 to 38°C)	All	TFE	-5** C

*Refer to Tech Bulletin for temperature range.
**Cryo Const. includes Special Cleaning #S-1134 (Opt.-55).

POSITION 3 - SIZES		
Size		CODE
in	(DN)	
1/4"	(8)	2
3/8"	(10)	3

POSITION 6 & 7 - TRIM DESIGNATION NUMBERS	
Brass Trim	
Desig.	CODE
B0*	B0
B2	B2
B3	B3
B4	B4
B5*	B5
BB	BB

*Suitable for Cryogenic Service.

POSITION 8 - Product Classification Under European "Pressure Equipment Directive"		
PRODUCT DESTINATION	HAZARD CATEGORY	CODE
Anywhere except Europe	N/A	7
European Countries *	Sound Engineering Practice (SEP)	S

* For products to be placed in service in Europe - Ref to Directive 2014/68/EU. Contact Cashco for Assistance.

POSITION 11 - RANGE SPRINGS			
Range Spring		Std	Opt -5
psig	(Barg)	CODE	CODE
2-6	(.14-.41)	8	
5-30	(.34-2.1)	1	A
20-80	(1.4-5.5)	2	B
70-140	(4.8-9.7)	3	C
130-200	(9.0-13.8)	4	D
Opt-20* Dome Loaded		Y	

*Not available with Cryogenic Construction

POSITION 12 - TRIM VARIATIONS		
Description	Option	CODE
No Option	--	0
Stabilizer (Recommended for gaseous service).	-4	4
For Special Construction Contact Cashco for Special Product Code.	SPQ	X

POSITION 13 - FEATURE OPTIONS		
Description	Option	CODE
No Option	-	0
Handwheel *	-2	2
Panel Mounting - (Opt-2 included). *	-22	C

* Not available with Cryogenic Construction

POSITION 15 - BODY OPTIONS		
Description	Option	CODE
No Option	-	0
Outlet Gauge Tap - 1/4" NPT (No Gauge).	-85	V

POSITION 16 - CERTIFICATE OPTIONS		
Description	Option	CODE
No Option	-	0
Special Cleaning: Per Cashco Spec #S-1134. Suitable for Oxygen Service.	-55	M
Special Cleaning: Per Cashco Spec #S-1542.	-56	N

Cashco, Inc.
P.O. Box 6
Ellsworth, KS 67439-0006
PH (785) 472-4461
Fax. # (785) 472-3539
www.cashco.com
email: sales@cashco.com
Printed in U.S.A. 3381-TB

Cashco GmbH
Handwerkerstrasse 15
15366 Hoppegarten, Germany
PH +49 3342 30968 0
Fax. No. +49 3342 30968 29
www.cashco.com
email: germany@cashco.com

Cashco do Brasil, Ltda.
Al.Venus, 340
Indaiatuba - Sao Paulo, Brazil
PH +55 11 99677 7177
Fax. No.
www.cashco.com
email: brazil@cashco.com