

MODEL 521

TOTAL TFE, GLOBE-PATTERN CONTROL VALVE



Model "521" Control Valve

APPLICATIONS

Designed specifically for corrosive chemical use, including most hazardous or toxic fluids. Ultimate performance when handling chlorine (wet or dry); bromine; hydrochloric, sulfuric, nitric, and hydrofluoric acids; and most industrial reagents. Also performs well in alkaline or strong basic fluids and most organics. Refer to Section "Chemical Resistance" on pages 8 and 9 for additional application information.

The Cashco Model 521 is a sliding stem, globe style, bellows sealed, pneumatically actuated control valve designed to provide superior long-term performance and maximum corrosion resistance in pure chemical service.

The design allows for all wetted internal parts to be machined from a solid block of isostatically compacted, virgin TFE, thus ensuring maximum density and the lowest possible permeability. An additional design benefit is that the wall thickness integrity is ensured as a result of the TFE body being internally machined after it is secured in a cast 304 SST body shell, thus preventing distortion problems related to the plastic stability of TFE. There is simply no better design or materials available when consideration is given to corrosion resistance and thermal stability.

DESIGN FEATURES

The Model 521 combines the TFE corrosion resistance with superior design and construction for the Chemical Process Industry:

- Unibody TFE construction minimizes potential leak paths.
- Dual stem seal design: 100,000 full-cycle bellows primary seal plus V-ring secondary stem seal.
- Anti-stem rotation device to prevent bellows damage.
- 304 SST body jacket resists external corrosion.
- Quick change trim with easily replaceable plug-tip.
- Four body sizes - 1/2", 1", 1-1/2", and 2"; (DN 15, 25, 40 and 50).
- Wide selection of trim sizes and forms.
- 150# RF, flanged body with "gasketless" pipe-to-valve joint.
- Optional capability to mate with 300# RF.
- Optional capability to mate with PN16, PN25, or PN40 DIN flanges.
- Class VI shutoff.
- Spring-loaded bonnet seal.
- All wetted parts are machined from isostatically compacted TFE.
- May be applied in full vacuum service.
- Standard Actuator compliant with IEC 60534-6-1 for mounting standardized positioners.

GENERAL SPECIFICATIONS

Body Sub-Assembly

Body Form:	Globe style; straight body pattern.	Seat Leakage:	ANSI/FCI 70-2 (Rev. 2006), Class VI.																								
Body Sizes:	1/2", 1", 1-1/2" and 2"; (DN 15, 25, 40 and 50).	Flow Direction:	Standard is Flow-to-Open (FTO).																								
Maximum Pressure & Working Temperature:	<p>Pressure Vs. Temperature application zone indicated in Graph No. 1:</p> <p>Pressure: Up to 275 psig (19.0 Barg). Full Vacuum: Down to 0 psia (-14.7 psig, -29.92" Hg); 0 BarA (-1.01 Barg, -760 mm Hg). Temperature Range: 0° to +310°F (-17.4° to + 155°C).</p>	Inherent Flow Characteristic:	Standard – Equal Percentage (Equal %). (Characteristic only maintained in FTO direction.)																								
End Connections:	<p><u>Standard</u> – 150# RF flanged; gasketless design. Flange bolt circle per ANSI B16.5. Bolt holes drilled and tapped to receive flange bolting.</p> <p><u>Optional ANSI</u> - 300# RF per above.</p> <p><u>Optional DIN</u> - Standard ANSI raised face dimensions on body. Mating bolt circle dimensions in accordance with DIN standard 2501 and ISO 2084, classes PN16, PN25 and PN40. Bolt holes drilled and tapped to receive metric bolting. Provided with compression molded TFE annular adapter gaskets to ensure proper loading of integral body gasket. (See Figure 2). Recommended to use flange gasket.</p>	Maximum Pressure Drop:	Up to 275 psid (19.0 Bard). Dependent on actuator size and bench set selection. See Table 2.																								
Stem Seal:	<p>Dual design —</p> <p><u>Primary Seal:</u> TFE bellows with 100,000 full stroke cycle design life.</p> <p><u>Secondary Seal:</u> TFE "V-ring" packing.</p>	Seat Design:	Integral TFE seat. Replaceable TFE plug-tip																								
		Flow Capacity Range:	<table border="1" style="width: 100%; border-collapse: collapse; text-align: center;"> <thead> <tr> <th colspan="2">Body Size</th> <th colspan="2">Max Capacity (Cv)</th> </tr> <tr> <th>In.</th> <th>(DN)</th> <th>Smallest Trim Size</th> <th>Largest Trim Size</th> </tr> </thead> <tbody> <tr> <td>1/2"</td> <td>(15)</td> <td>.10</td> <td>2.5</td> </tr> <tr> <td>1"</td> <td>(25)</td> <td>.10</td> <td>10.0</td> </tr> <tr> <td>1-1/2"</td> <td>(40)</td> <td>6.3</td> <td>21.0</td> </tr> <tr> <td>2"</td> <td>(50)</td> <td>10.0</td> <td>40.0</td> </tr> </tbody> </table>	Body Size		Max Capacity (Cv)		In.	(DN)	Smallest Trim Size	Largest Trim Size	1/2"	(15)	.10	2.5	1"	(25)	.10	10.0	1-1/2"	(40)	6.3	21.0	2"	(50)	10.0	40.0
Body Size		Max Capacity (Cv)																									
In.	(DN)	Smallest Trim Size	Largest Trim Size																								
1/2"	(15)	.10	2.5																								
1"	(25)	.10	10.0																								
1-1/2"	(40)	6.3	21.0																								
2"	(50)	10.0	40.0																								
		Rangeability:	<p>See Table 1 for theoretical Cv @ % travel.</p> <p><u>Equal % Characteristics</u> - available in all trim sizes.</p> <p>Standard – 50:1, except 1/4" (6 mm) orifice.</p> <p>Minimum – 25:1 for 1/4" (6mm) orifice. See Table 1.</p>																								

Actuator Sub-Assembly Models: C27 & C53

Design:	Spring-diaphragm type.	Supply Connection:	1/4" female NPT.
Ambient Temp. Range:	-50 to +180°F (-45 to +83°C). -20° to +140°F (-29° to +60°C) with electrical accessories.	Mounting Position:	<u>Model</u> Horizontal-to-vertically up, and all angles in between.
Bench Set:	See Table 2.	Painting:	<u>Standard</u> – All non corrosion resistant portions are powder coated per Spec. S-1743 and/or with corrosion resistant epoxy paint per Cashco Spec #S-1606.
Supply Pressure:	See Table 2. Design Max is 100 psig.	Alternate:	See Opt-95.
Stroke:	1/2" Size = 0.500" 1" through 2" Size = 0.750".	Sizes, Strokes & Volumes:	See Table 3.

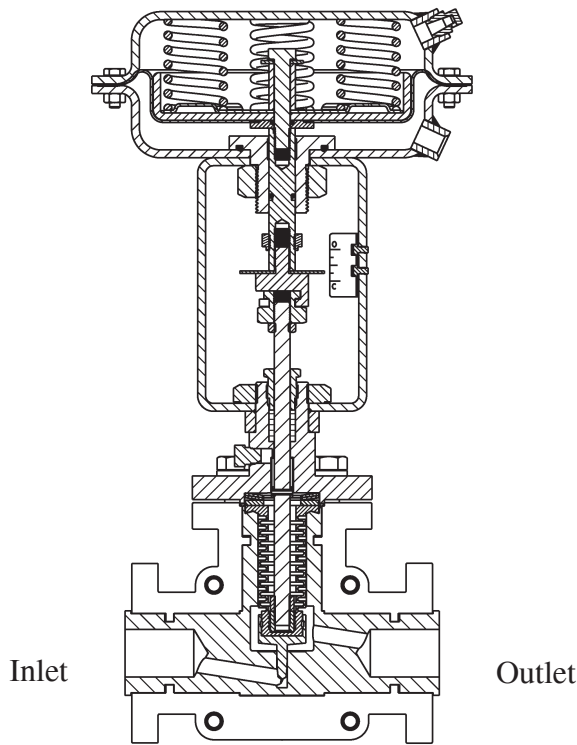
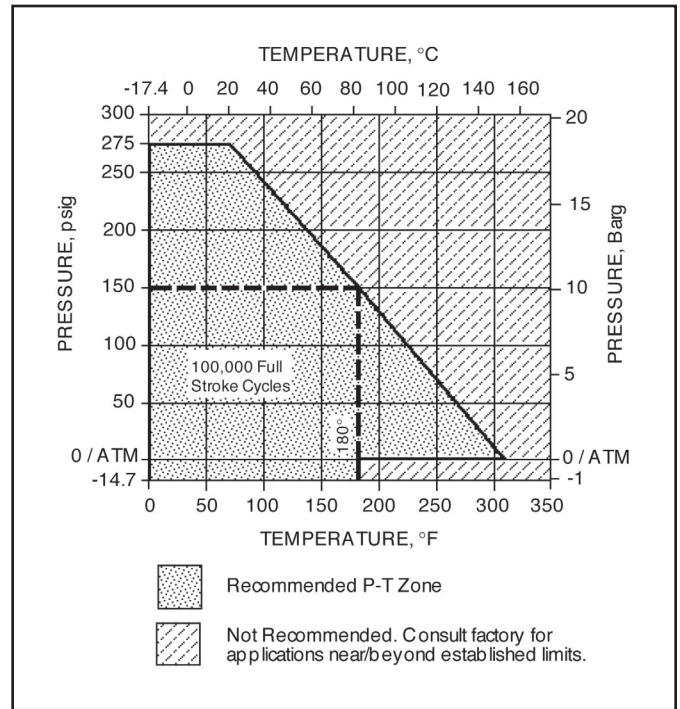

Figure 1
Model "521" Cross-Section



GRAPH NO. 1

MATERIALS SPECIFICATIONS

Body Sub-Assembly

Body, Plug Head & Bellows: Isostatically compacted, high density TFE - tetrafluoroethylene; i.e. PTFE – poly-tetrafluoroethylene. Precision machined. (Note: TFE or PTFE are used as abbreviations; they are the same material.)

Body Shell and Bonnet: Investment castings. Cast 304 SST per ASTM A351-CF8.

Body & Bonnet Bolting: 18-8 SST.

Bonnet Gasket: TFE.

Secondary Packing: TFE – “V-ring”.

Belleville Spring Washers: 18-8 SST.

Stem Assembly: Standard: 316 SST stem and anti-rotational stop; 420 SST pin (body sizes 1/2" (DN 15) and 1" (DN 25)), silver soldered (body sizes 1-1/2" (DN 40) and 2" (DN 50)). Embedded stem-to-bellows connection nut of 316 SST.

Optional: Two optional stem constructions available - both utilize Hastelloy body to bonnet bolting.

Option "D" – Hastelloy C-22 stem, anti-rotational stop and pin, and embedded stem-to-bellows connector nut.

Option "F" – Hastelloy C-22 stem only. Stop and pin of standard materials.

NOTE: Alternate stem materials should be considered when the fluid is known to permeate TFE and is corrosive to 316 SST in the presence of moisture. See Section “Chemical Resistance” and Options “D” and “F” above.

Packing Follower: 18-8 SST.

Actuator Sub-Assembly

Part	Material
Diaphragm	Buna-N w/Polyester Insert
Lower & Upper Case, Yoke	Steel
Attachment Hub	17-4 PH SST
Stem	316/316L SST
Diaphragm Plate, Stem Spacer, Stem Lock Washer, Spring Plate, Hub Nut, Stem Bolt	Steel
Spring	Epoxy Coated Steel
Diaphragm Washer	316/316L SST
Diaph. Washer O-ring, Hub O-ring, Stem O-ring	Buna-N
Bolts & Nuts	Steel Plated

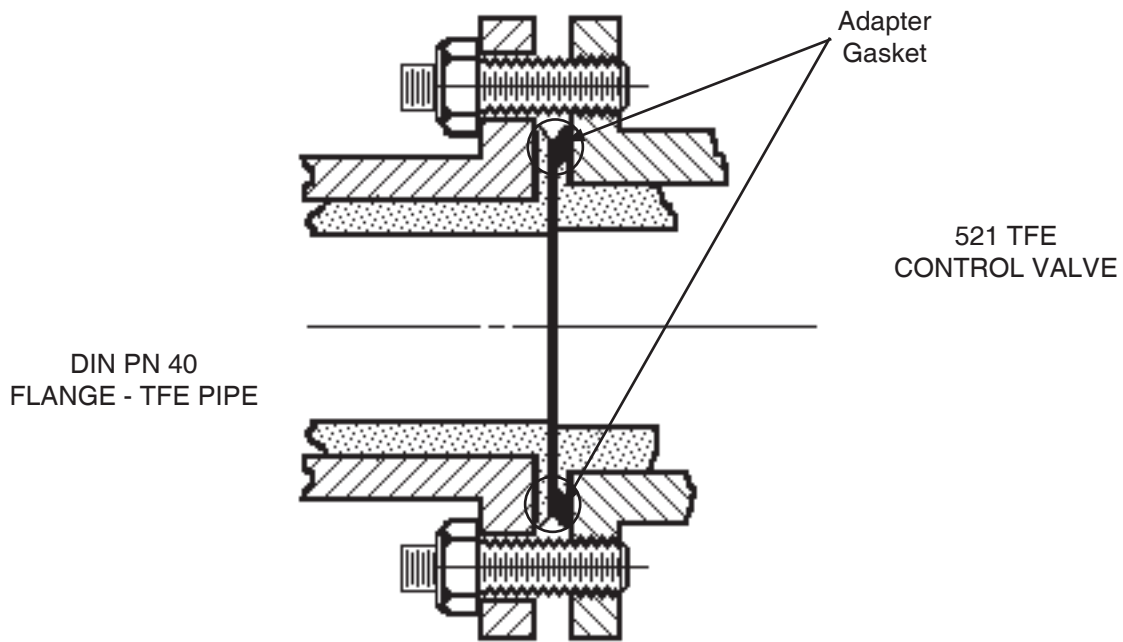

FIGURE 2
ANSI / DIN ADAPTER GASKET

TECHNICAL SPECIFICATIONS

**TABLE 1
MODEL 521
THEORETICAL CAPACITY**

EQUAL % CHARACTERISTIC

F_L Factor = 0.90

Body Size		Orifice Size		Rangeability	Minimum Controllable Cv	Cv @ 10% Travel Increments									
In.	(DN)	In.	(mm)			10%	20%	30%	40%	50%	60%	70%	80%	90%	100%
1/2"	(15)	0.250"	(6.35)	25:1	0.004	.015	.015	.015	.016	.020	.027	.038	.052	.075	0.10
					0.006	.015	.017	.020	.024	.033	.045	.064	.085	.12	0.16
					0.010	.015	.019	.026	.036	.051	.069	.099	.13	.19	0.25
					0.016	.023	.035	.046	.058	.081	.11	.15	.21	.29	0.40
					0.025	.040	.051	.063	.085	.12	.17	.24	.33	.46	0.63
		0.438"	(11.12)	50:1	0.020	.020	.041	.061	.102	.14	.20	.32	.46	.68	1.00
					0.032	.051	.071	.10	.15	.24	.33	.49	.73	1.0	1.60
1"	(25)	0.250"	(6.35)	25:1	0.004	.015	.015	.016	.019	.023	.028	.039	.052	.066	0.10
					0.006	.015	.016	.018	.024	.033	.044	.062	.084	.12	0.16
					0.010	.015	.019	.026	.038	.053	.069	.097	.13	.18	0.25
					0.015	.015	.025	.044	.064	.087	.11	.16	.21	.30	0.40
					0.025	.035	.046	.069	.091	.13	.17	.23	.34	.46	0.63
		0.562"	(14.27)	50:1	0.020	.052	.078	.103	.129	.15	.21	.31	.46	.68	1.00
					0.032	.065	.091	.11	.14	.22	.32	.49	.72	1.08	1.60
					0.050	.07	.12	.17	.24	.35	.52	.77	1.14	1.70	2.50
					0.080	.10	.17	.27	.37	.58	.85	1.24	1.84	2.70	4.00
		0.875"	(22.22)	50:1	0.100	.14	.22	.32	.46	.68	1.02	1.49	2.18	3.50	5.00
					0.126	.18	.26	.40	.58	.90	1.33	1.95	2.85	4.25	6.30
					0.150	.22	.34	.50	.72	1.06	1.57	2.32	3.42	5.08	7.50
					0.200	.28	.40	.62	.90	1.32	1.92	2.77	4.13	6.73	10.0
					0.250	.35	.46	.69	.91	1.33	1.95	2.85	4.25	6.30	10.0
1-1/2"	(40)	0.875"	(22.22)	50:1	0.126	.20	.28	.40	.60	.88	1.31	1.93	2.86	4.24	6.30
					0.150	.22	.34	.51	.74	1.06	1.57	2.34	3.45	5.08	7.50
		1.500"	(38.10)	50:1	0.200	.28	.42	.62	.97	1.38	2.11	3.07	4.54	6.70	10.0
					0.300	.41	.70	.97	1.45	2.14	3.14	4.64	6.88	10.1	15.0
					0.420	.62	.90	1.38	2.14	3.14	5.82	13.6	15.9	18.0	21.0
2"	(50)	1.500"	(38.10)	50:1	0.200	.32	.48	.73	1.05	1.53	2.25	3.26	4.80	6.69	10.0
					0.300	.42	.63	.97	1.45	2.14	3.16	4.64	6.88	10.9	15.0
					0.500	.76	1.27	2.16	3.60	5.64	8.38	11.8	16.0	20.7	25.0
		1.750"	(44.45)	50:1	0.700	1.18	2.09	3.55	5.74	8.78	14.9	20.9	26.1	30.7	35.0
					0.800	1.49	2.58	4.31	9.65	16.1	21.7	26.8	31.6	36.0	40.0

**TABLE 2
 MAXIMUM PRESSURE DROP – psid (Bard)
 ATO-FC; REVERSE ACTION
 ATC-FO; DIRECT ACTION
 FTO DIRECTION**

Body Size		Port Orifice		Maximum Operating Pressure Drop		Actuator		Air Supply Pressure		
		Description	Size			Bench Settings				Model No.
inch	(DN)		inch	(mm)	psid	(Bard)	psig	(Barg)	psig	
1/2"	(15)	Full	.438"	(11.12)	275	(19.0)	3-17	(0.21-1.17)	20	(1.4)
		1-Step Reduced	.250"	(6.35)						
1"	(25)	Full	.875"	(22.22)	275	(19.0)	7-28	(0.48-1.93)	35	(2.4)
		1-Step Reduced	.562"	(14.27)			5-15	(0.34-1.03)		
		2-Step Reduced	.250"	(6.35)			3-17	(0.21-1.17)		
1-1/2"	(40)	Full	1.500"	(38.10)	222	(15.3)	15-60	(1.03-4.14)	75	(5.2)
		1-Step Reduced	.875"	(22.22)	97	(6.7)	5-15	(0.34-1.03)	20	(1.4)
2"	(50)	Full	1.750"	(44.45)	156	(7.9)	15-60	(1.03-4.14)	75	(5.2)
		1-Step Reduced	1.500"	(38.10)	64	(4.4)	5-15	(0.34-1.03)	20	(1.4)
					222	(15.3)	15-60	(1.03-4.14)	75	(5.2)
					97	(6.7)	5-15	(0.34-1.03)	20	(1.4)

Application Note: Consult factory for applying these valves with an I/P Transducer without a positioner. Pressure drop levels may be reduced.
 DO NOT apply ATC-FO arrangement with I/P Transducer - could cause permanent damage to valve.

**TABLE 3
 Actuator Size, Stroke & Volumes**

Nominal Diaphragm Area		Stroke		Actuator Action	Volumes			
					Clearance		Displacement	
in ²	(cm ²)	in	(mm)		in ³	(cm ³)	in ³	(cm ³)
32	(209)	0.50"	(12.7)	ATC	30.3	(496.5)	16.2	(265.5)
				ATO	28.2	(462.1)	16.4	(268.7)
		0.75"	(19.05)	ATC	25.8	(422.8)	25.4	(416.2)
				ATO	24.4	(399.8)	24.1	(394.9)
53	(342)			ATC	38.4	(629.3)	39.3	(644.0)
				ATO	36.9	(604.7)	39.0	(639.0)

OPTION SPECIFICATIONS

Option-3:

Manual Handwheel: Handwheel overrides the actuator spring force to allow manual stroking of the valve. Single acting design, side-mounted, enclosed handwheel. For ATO-FC action, handwheel operator "opens" the valve against spring force; may be utilized as a travel stop to prevent full closure. For ATC-FO action,

handwheel operator "closes" the valve against spring force; may be utilized as a travel stop to prevent full opening.

Option-57:

SPECIAL CLEANING: Per Cashco Specification S-1589 for Chlorine Service. Unit construction includes Alloy 20 body to bonnet bolting per Chlorine Institute Pamphlet No. 6.

Option-95: EPOXY PAINT: Special epoxy painting of all non-corrosion resistant exterior surfaces per Cashco Spec #S-1547. Utilized in harsh atmospheric conditions.

MOUNTED ACCESSORY SPECIFICATIONS

Positioners:	<p><u>General:</u> PMV Positioners. Aluminum housing with corrosion resistant powder coated epoxy. Pneumatic output load as required by actuator bench range. Field reversible action. Mounting dimensions per IEC 60534-6-1 Standard.</p> <p>P/P Pneumatic. Model P5 features SST cam with a simple cam locking device, tapped exhaust port for venting media, external zero adjustment. Input signal 3-15 psig, Includes gauge ports, no gauges. Analog only.</p> <p>I/P Electro-Pneumatic. Model D20 Digital or Hart compatible. Features single button self-calibration. input signal 4-20mA. Optional gauge block with gauges for Models D20 D and D20 I.</p> <p>Model D20 D is general purpose.</p> <p>Model D20 I is Intrinsically safe, ATEX Ex ia IIC T4, FM CLS 1 DIV 1, FM Non-incendive CLS 1 DIV 2.</p> <p>Model D20 E is ATEX EEX d IIB+H₂, T6 FM Approved. Gauge block is built in, no gauges. Not available with limit switch option.</p> <p>Model D3 Digital, Hart, Profibus, or Fieldbus compatible. Input signal 4-20mA. Features large graphic display. Optional gauge block for Models D3 X and D3 I, no gauges.</p> <p>Model D3 X is general purpose.</p> <p>Model D3 I is Intrinsically safe, ATEX EEX ia IIC T4.</p> <p>Model D3 E is ATEX EEX d IIB+H₂, T6 CSA CLS 1 DIV 1 FM CLS 1 DIV 1 Gauge block is built in, no gauges. Not available with limit switch option.</p> <p>Model PS2 is Hart, Fieldbus and Profibus compatible. Input signal 4-20mA. Features a Makrolon housing, (Aluminum for Explosion Proof.) Mounting dimensions per IEC 60534-6-1 Standard.</p> <p>Model PS2-1 is general purpose.</p> <p>Model PS2-2 is Intrinsically safe, ATEX Ex ia IIC T6/T4, FM CLS 1 DIV 1, CSA CLS 1 DIV 1, SIL 2</p> <p>Model PS2-3 EX d IIC T6/T4, SIL 2</p> <p>All I/P positioners not available with 764's.</p>	<p>Instrument Air Tubing: Instrument air tubing SST with SST fittings.</p> <p>Airset: Model 5200P instrument air supply regulator. Use with positioners. Bracket mounted to actuator casing. Supplied with gauge. See technical bulletin 5200P-TB.</p> <p>3-Way Solenoid Valve: <u>Standard Brass:</u> Available in standard weather-proof model. Brass body, 1/4" female NPT connections. Nipple mounted to actuator casing. 120 VAC, 60 Hz power supply, CSA Approved Class 3221-01, NEMA 2,3,3S,4,4X. 8" HF utilizes a direct mount NAMUR mount style.</p> <p><u>X-Proof or SST construction:</u> Consult Factory.</p> <p>Standard installation vents actuator and drives valve to fail-safe position upon loss of electrical power.</p> <p>Consult factory for 230/1/50, or 120 VDC power supplies, or intrinsically safe (IS) service.</p> <p>Transducer: FM, CSA approved NEMA 4X CI 1, Div 1 and CI 1, Div 2</p> <p>Other Accessories: 764 P/PD pressure controller. Lockup valve. Position transmitter.</p> <p>Limit Switches: Model D20 and D3 positioners, switches are available, unit is enclosed in the positioner housing.</p> <p>Limit switch options not available on Explosion proof rated positioners.</p>
---------------------	---	--

CHEMICAL RESISTANCE

General Statement: Statements located within this technical bulletin concerning suitability of fluids with TFE materials are general statements, and should not be construed as recommendations. Any statements of suitability are the result of a compilation of various sources of information based on experience, tests, and published technical literature. No guarantee or warranty is in anyway implied for a given particular service or application.

Additional Reference: For an inclusive listing covering a broader range of service application fluids, reference "Handbook of Corrosion Resistant Piping", P.A. Schweitzer, Industrial Press; or "Compass Corrosion Guide", 2nd Edition, K.M. Pruett, Compass Publications. This publication will include information based on the following fluid variables:

1. Solution concentration
2. Pressure
3. Temperature

Chemical Resistance of TFE. TFE is, in general, inert to chemical corrosion of nearly all known industrial or commercial chemicals. When applied within the P vs. T zone of Graph No. 1, the following partial listing represents general classifications of fluids that normally do not corrode TFE:

- Strong inorganic acids – HCl, H₂SO₄, aqua regia
- Strong caustics or bases - NaOH, KOH
- Bleaches
- Oxidizers (except F₂ related chemicals)
- Organic acids
- Aliphatic and aromatic hydrocarbon solvents
- Chlorides
- Sulfates
- Peroxides
- Phenols
- Alcohols
- Esters
- Ketones
- Ethers

A partial listing of fluids that are known to chemically react with TFE and should not be applied are:

- Molten alkali metals – Na, K, Li
- Molten anhydrous bases – NaOH
- Fluorine gas (dry) above 250°F (121°C)
- Strong fluorinating agents – ClF₃, OF₂
- Hydrogen fluoride (dry) above 220°F(104°C)

Absorption. Depending on concentration, pressure and temperature conditions, some fluids absorb trace (minute) quantities into the wetted surfaces of TFE. When pressure is suddenly reduced or temperature increased, the absorbed fluids can "expand" and cause physical damage to the polymerized molecules. Blisters may be formed. Controls to eliminate/minimize sudden temperature and/or pressure changes are recommended. Chemical resistance is not compromised when absorption occurs.

Permeation. Depending on concentration, pressure and temperature conditions, certain fluids permeate (pass through) TFE molecular structure in trace quantities. Effects of pressure/temperature changes are similar to absorption effects. As with absorption, chemical resistance of the TFE is not reduced. Added considerations are:

- a. purging of non-wetted (backside) of bellows
- b. alternate stem materials.

See Table 4 for a partial listing of fluids known to permeate TFE.

TABLE 4 Chemicals Known To Permeate TFE		
* Ammonium beryllium fluoride	Ethylene chloride	Naphthalene
Benzene	Ethylene dibromide	Nitric acid
* Bromine	Ethylene dichloride	Nitrobenzene
* Bromine (water - 3% saturated)	* FREON Fluorocarbons	Nitromethane
* Bromine chloride	Hexane	Oxygen
Butane	* Hydrobromic acid	Perchloroethylene
Butyl bromide	* Hydrochloric acid	Phenol
Butyl chloride	* Hydrofluoric acid	* Phosgene
Butyl phenol	Hydrogen	Potassium cyanide
Butylene (Butadiene)	* Hydrogen chloride	Propane
Carbon bisulfide	* Hydrogen cyanide	Propylene oxide
* Carbon tetrachloride	* Hydrogen fluoride gas	Styrene monomer
Chlorinated phenol	Hydrogen sulfide	Sulfur trioxide
* Chlorine (5% in CCl ₄)	* Iodine (gas)	Sulfuric acid
* Chlorine dioxide	* Iodine (Tincture of)	Tetrahydrofuran
* Chlorine	Methane	Toluene
* Chlorobenzene	Methyl chloride	Toluene (25%) + kerosene (75%)
* Chlorobenzyl chloride	** Methyl chloroform	1,1,2-Trichloroethane
Chloroform (Trichloromethane)	** Methyl chloromethyl ether	Trichloroethylene
* o-Dichlorobenzene	Methyl ethyl ketone	** Trimethyl propane
Dichloroethane	Methyl isobutyl ketone	Vinyl chloride monomer (liquid)
Diethyl ether	** Methylene bromide	** Vinylidene chloride (monomer)
* Ethyl benzene (acidic)	Methylene chloride	Xylene
Ethyl ether	Naphtha	
* Fluids where alternate stem materials are recommended.		
** Corrosion effects on metallic parts unknown.		

CONSIDERATIONS FOR ALTERNATE STEM MATERIALS

When a fluid permeates TFE, the rate of permeation is very low, and the molecules will diffuse uniformly into the “gaseous void” or “non-wetted” zone in the center portion of the bellows of a Model 521. These molecules can come in contact with metallic, non-TFE parts, including the stem. With each stroke of the valve stem downwards, molecules of water vapor in the atmosphere are entrapped in the peaks and valleys of the stem’s microstructure, and are drawn down into the secondary packing rings. As the stem retracts, a molecule of the permeated fluid may be pulled up into the packing rings. If the molecules of moisture and permeated fluid come into contact, a “solution” may be formed. This “solution” will be highly “concentrated” and can be highly corrosive. If the stem material is vulnerable to the concentrated solution, chemical attack of the valve stem in the mid-range of the packing zone may begin. Once this mechanism begins, the result may lead to premature stem failure.

Examples of gases which permeate TFE in microscopic quantities are hydrogen sulfide (H₂S) and chlorine gas (Cl₂). When dissolved in moisture (H₂O) —

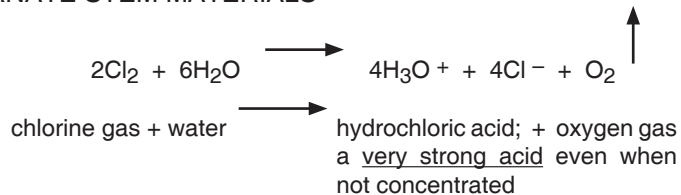
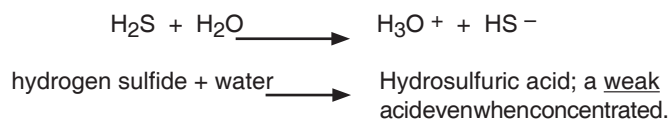

— acids are formed in both cases. The hydrosulphuric acid is a weaker acid that 316 SST is sufficiently corrosion resistant against. However, the hydrochloric acid is a strong acid that corrosively attacks 316 SST. Both increased pressure and temperature accelerate the corrosive mechanism. However, the overall rate of corrosion is very low as the permeation rate is very low. Chlorine gas is an example of a fluid where alternate stem construction of Hastelloy C-276 will maximize unit life and proper functioning of the secondary stem seal design. Use of alternate stem material is subjective and dependent on many various factors, and is like most CPI decisions, based on value judgement.

NOTE: The corrosive effects are primarily limited to the stem/secondary packing rings zone where moisture and acid molecules interface.

TABLE 5
Flange Stud Bolting Size / Thread Guide

Body Size		End Connection Flange			Recommended Stud Length	
in.	(DN)	150# - Dim "F"	300# - Dim. "F"	PN 16/25/40 - Dim "F"	in	(mm)
1/2"	(15)	1/2"-13 UNC-2B	1/2"-13 UNC-2B	14 mm - M12 x 1.75-6H	2.00"	(50)
1"	(25)	1/2"-13 UNC-2B	5/8"-11 UNC-2B	14 mm - M12 x 1.75-6H	2.25"	(56)
1-1/2"	(40)	1/2"-13 UNC-2B	3/4"-10 UNC-2B	18 mm - M16 x 2.0-6H	2.75"	(70)
2"	(50)	5/8"-11 UNC-2B	5/8"-11 UNC-2B	18 mm - M16 x 2.0-6H	3.00"	(75)
"L" - # Bolt Holes		4	4/8 *	4	--	--
* 2" - 300# flg. requires 8; all others 4. NOTE: All flange bolt holes straddle center lines.						

The contents of this publication are presented for informational purposes only, and while every effort has been made to ensure their accuracy, they are not to be construed as warranties or guarantees, express or implied, regarding the products or services described herein or their use or applicability. We reserve the right to modify or improve the designs or specifications of such product at any time without notice. Cashco, Inc. does not assume responsibility for the selection, use or maintenance of any product. Responsibility for proper selection, use and maintenance of any Cashco, Inc. product remains solely with the purchaser.

DIMENSIONS & WEIGHTS

English Units - inches and lbs.

End Conn.	Dimension	Body Size			
		1/2"	1"	1-1/2"	2"
ACTUATOR MODEL # C27 & C53					
ALL	A	4.63	5.88	7.75	7.69
	B (C27)	14.09	15.34	17.21	17.15
	B (C53)	NA	NA	17.35	17.29
	C (C27)	17.28	18.53	20.40	20.34
	C (C53)	NA	NA	21.32	21.26
	D	C27 Act. = 9.00" / C53 Act. = 11.56"			
	E	C27 Act. = 9.97" / C53 Act. = 11.21"			
	F	5.19	7.44	8.75	10.40
H	3.53	4.88	6.50	6.38	
150# FLGD.	G	1.75	2.13	2.50	3.00
	K	2.38	3.12	3.88	4.75
300# FLGD.	G	1.88	2.44	3.06	3.25
	K	2.62	3.50	4.50	5.00
DIN FLGD.	G	1.88	2.44	3.06	3.25
	K	2.56	3.35	4.33	4.92
Wt. w C27 Act.		28	38	60	65
Wt. w C53 Act.		--	--	70	75

Metric Units - mm and kg

End Conn.	Dimension	Body Size			
		DN15	DN25	DN40	DN50
ACTUATOR MODEL # C27 & C53					
ALL	A	117.6	149.4	196.9	195.3
	B (C27)	357.9	389.6	437.1	435.6
	B (C53)	NA	NA	440.7	439.2
	C (C27)	438.9	470.7	518.2	516.6
	C (C53)	NA	NA	541.5	540.0
	D	C27 Act. = 228.6 / C53 Act. = 293.6			
	E	C27 Act. = 253.1 / C53 Act. = 284.7			
	F	131.8	189.0	222.3	264.2
H	89.7	124.0	165.1	162.1	
150# FLGD.	G	44.5	54.1	63.5	76.2
	K	60.5	79.2	98.6	120.7
300# FLGD.	G	47.8	62.0	77.7	82.6
	K	66.5	88.9	114.3	127.0
DIN FLGD.	G	47.8	62.0	77.7	82.6
	K	65.0	85.0	110.0	125.0
Wt. w C27 Act.		12.7	17.2	27.2	29.5
Wt. w C53 Act.		--	--	31.7	34.0

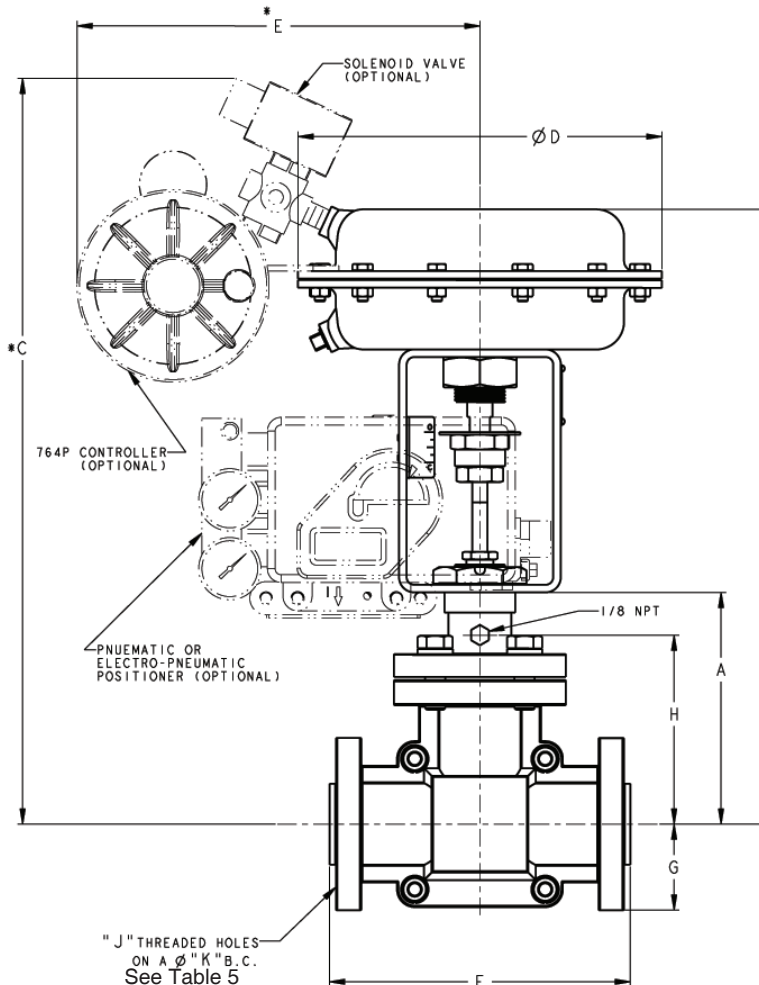

**Figure 3
Body & Actuator**

MODEL 521 PRODUCT CODER 02/25/16

An "X" in POS 12 followed by a 5-digit control number overrides remaining selections.

S	T	POS 3	—	POS 5	POS 6	0	POS 8	—	0	POS 11	POS 12	POS 13	POS 14	POS 15	POS 16	POS 17	G
----------	----------	-------	---	-------	-------	----------	-------	---	----------	--------	--------	--------	--------	--------	--------	--------	----------

POSITION 3 - BODY SIZE		
Body Size		CODE
in	(DN)	
1/2"	(15)	1
1"	(25)	2
1-1/2"	(40)	A
2"	(50)	4

POSITION 5 - STEM MAT'L & END CONNECTIONS			
Stem	RF Flange		
	150# *	300#	DIN **
	CODE		
Standard	B	G	1
Option "D" Hast. C Stem, Anti-Rotation Stop & Pin	D	H	2
Option "F" Hast. C Stem, SST Pin & Anti- Rotation Stop	F	J	3

* Standard End Connection
** DIN PN 16/25/40

POSITION 6 - TRIM C _v SIZE			
Orifice Size	Applicable Valve Body Sizes	Trim C _v Size	CODE
.250"	1/2" & 1"	0.10 Reduced	E
		0.16 Reduced	F
		0.25 Reduced	G
		0.40 Reduced	H
		0.63 Full	J
.438"	1/2" Only	1.00 Reduced	K
		1.60 Reduced	L
		2.50 Full	M
.562"	1" Only	1.00 Reduced	P
		1.60 Reduced	R
		2.50 Reduced	S
		4.00 Reduced	T
		5.00 Full	U
		6.30 Reduced	V
.875"	1" & 1-1/2"	7.50 Reduced	W
		10.0 Full	1
		10.0 Reduced	Y
1.500"	1-1/2" & 2"	15.0 Reduced	2
		21.0 Full	6
	2" Only	25.0 Full	3
1.750"	2" Only	35.0 Reduced	4
		40.0 Full	5

POSITION 8 - Product Classification Under European "Pressure Equipment Directive"		
PRODUCT DESTINATION	HAZARD CATEGORY	CODE
Anywhere except Europe	N/A	7
European Countries * (CE Mark does not apply to DN25 and below)	Sound Engineering Practice (SEP)	S
	CE Marked Hazard Cat I or II	E

* For products to be placed in service in Europe - Ref to Directive 2014/68/EU.
Forward Completed "EU" Application Recorder prior to quotation. (Without Recorder- Processing of Purchase Order will be delayed). Contact Cashco for Assistance.

POSITION 11 - ACTUATOR / BENCH SET / ACTION / SIZE				
Model	Bench Setting psig	Reverse Action ATO - FC	Direct Action ATC - FO	Valve Size
	CODE			
C27	3-17	A	E	1/2" & 1"
	5-15	B	F	1"
	7-28	C	H	1" & 1-1/2"
	15-60	D	J	1-1/2" & 2"
C53	5-15	K	L	1-1/2" & 2"
No Actuator		0		All

NOTE: Consult Table 2 in Tech Bulletin to confirm Pressure Drop Capability.

POSITION 12 - 764P * (Bracket Mounted) - AIRSET (Bracket Mounted) - SOLENOID VALVES			
764P Action	Solenoid Valve *** Exhaust on Deenergization		
	None	120VAC 60 Hz	24 VDC
None	CODE		
	0	6	C
Reverse **	2	8	E
Reverse W/ Airset **	3	9	F
Direct **	4	A	G
Direct W/ Airset **	5	B	H
For Special Construction Contact Cashco for Special Code	X		

* Refer to 764-TB for Product Code of Controller.
** Select Code 1 on Position 13 if positioner is needed.
*** Solenoid rated as 4/4X only.

POSITION 13 - DIRECT ACTING POSITIONER with AIRSET (Bracket Mounted) (3-15 psig) 4-20 mA Specify Split Range in Special Instructions on the P.O.						
Positioner Model	Ratings	Analog/Digital	Hart	Fieldbus	Profibus	
	CODE					
P5 P/P *	Gen. Purpose	1				
D20 D I/P	Gen. Purpose	C	D			
D20 I I/P *	Intrinsically Safe	2	5			
D20 E I/P ***	Explosion Proof	E	F			
D3 X I/P	Gen. Purpose	L	M	N	P	
D3 I I/P	Intrinsically Safe	3	6	8	A	
D3 E I/P ****	Explosion Proof	G	H	J	K	
PS2-1 I/P	Gen. Purpose		R	S	T	
PS2-2 I/P	Intrinsically Safe		7	9	B	
PS2-3 I/P ***	Explosion Proof		U	V	W	
None **		0				

* Stock Item
** Actuator Assembly includes dimensions for (Namur) Mounting per IEC 60534-6-1.
*** Not available with limit/proximity switch option. Select codes "8", "9" or "0" in Pos. 15.
**** Not available with options. Please select code "0" in Pos. 15.

POSITION 14 - GAUGE BLOCK	
Option for Positioner	Code
None *	0
Gauge Block **	1

* For P5 gauge ports built in. No gauges.
* For D20 E, D3 E & PS2-3 gauge block is standard. No gauges.
** For D20 D & D20 I and PS2-1 & PS2-2 - gauge block with gauges.
** For D3 X & D3 I gauge block only - no gauges.

POSITION 16 - OPTIONS	
Accessories	CODE
No Handwheel	0
Handwheel	9

POSITION 15 - POSITIONER OPTIONS							
Options	POSITIONERS			I/P TRANSDUCERS *			
	Inductive Limit Switches	Micro-switches Limit Switches	Position Transmitter	3-15 PSIG No Airset	3-15 PSIG W/ Airset	0-60 PSIG No Airset	0-60 PSIG W/ Airset
	CODE						
P5				4	5		
D3 & D20	7	T *	9				
PS2			8				
No Positioner				C	F	R	S
None	0						

* For 0-60 Psig Transducer please contact the factory.

POSITION 17 - PAINTING & CLEANING			
Painting	Option	Standard Cleaning	Opt-57 Cleaned to Spec. #S-1589
		CODE	
Standard	-	0	A
Epoxy Painted Per Cashco Spec #S-1547	-95	1	B

Cashco, Inc.
P.O. Box 6
Ellsworth, KS 67439-0006
PH (785) 472-4461
Fax. # (785) 472-3539
www.cashco.com
email: sales@cashco.com
Printed in U.S.A. 521-TB

Cashco GmbH
Handwerkerstrasse 15
15366 Hoppegarten, Germany
PH +49 3342 30968 0
Fax. No. +49 3342 30968 29
www.cashco.com
email: germany@cashco.com

Cashco do Brasil, Ltda.
Al.Venus, 340
Indaiatuba - Sao Paulo, Brazil
PH +55 11 99677 7177
Fax. No.
www.cashco.com
email: brazil@cashco.com