

RCEL005 / RCEL006-250

High quality electric actuators

ROTORK SWEDEN has been manufacturing actuators since 1961

Technical Data



RCEL005



RCEL006-250

RCEL – series meet all International Standards for easy and quick mounting of actuators on valves.

The RCEL Actuator has a smooth and easy operation which considerably increases the life expectancy of the valve.

The technical advantages of the electrical actuators produced by Remote Control are much appreciated by our customers.

“Power Start”

The RCEL-series has an unique rising of the rpm prior to start which results in a higher starting torque. This is necessary when valves have been sitting idle for a long time and initially need more force to be manoeuvred.

RCEL006-250 is also available with extended rotation angle and in explosion-safe design.

Accessories such as local control units or digital regulation cards and positioners can easily be installed.

- For On-Off regulation.
- Torque range: 50 Nm - 2,452 Nm.
443 lbf.in - 21,702 lbf.in.
- Mounting kits for all 90° valves.
RCEL006-250 also for 120°, 135°, 180°, 270° och 300°.
- Connections and hole constellations in compliance with International standard ISO5211 (DIN 3337) and DIN 79.
- Permanently lubricated and self locking gear drive.
- Temp: RCEL005: -20° to + 70 °C
RCEL006-250: -30 to + 70 °C
- Feed Voltage:
RCEL005: 24 VDC (Option 24 VAC).
110 / 230 VAC, 1-phase.
RCEL006-250: 24 VDC (Option 24 VAC).
110 / 230 VAC, 1-phase.
380/400/440 VAC, 3-phase.
- Safety Class:
RCEL005: IP 67
RCEL006-250: IP 67 (Option 68)
- CE labelled.
Approval CSA - UL.
ATEX (Option).
- Manual Override in case of power failure.
- Smooth running.
- Compact proportions.
- Built-in heater preventing condensation.
- Housing made from centrifugally cast anodized and epoxy painted aluminium.
- Long life, maximum dependability.

www.rotork.com www.remotecontrol.se



ROTORK SWEDEN AB

Box 80, Kontrollvägen 15, SE-791 22 Falun, Sweden
Tel: +46 (0)23-587 00 • Fax: +46 (0)23-587 45 • falun.info@rotork.com

RCEL005 - Compact - Adaptable - 50 Nm

Limit Switches

2 potential-free Switches
2 limit-position Switches

Indicator

Illuminated indicator for visual indication of end position

Motor

Fully enclosed
Quiet operation
Thermal motor protection

Connection

Vibration-safe plinths
No special tools needed

Screws

External screws stainless steel

Space Heater

Prevents condensation

Self-locking gears

Mechanical breaks not needed
Permanently lubricated

Cabel input

M20 x 1,5

Highest Surface Finish

Centrifugally cast aluminium
Externally and internally anodized
Dry Powder Epoxy painted

Emergency Operation

Manually with 6 mm hex key

Mounting Flange

ISO 5211 (DIN 3337)
F03 - F05 - F07



High casing on RCEL005L

To facilitate mounting of accessories



Rotation axle

Complies with International standard for square spindles, ISO 5211 och DIN 79, 14 mm

RCEL006-250 - The strong choice - Up to 2,450 Nm - Even EEx

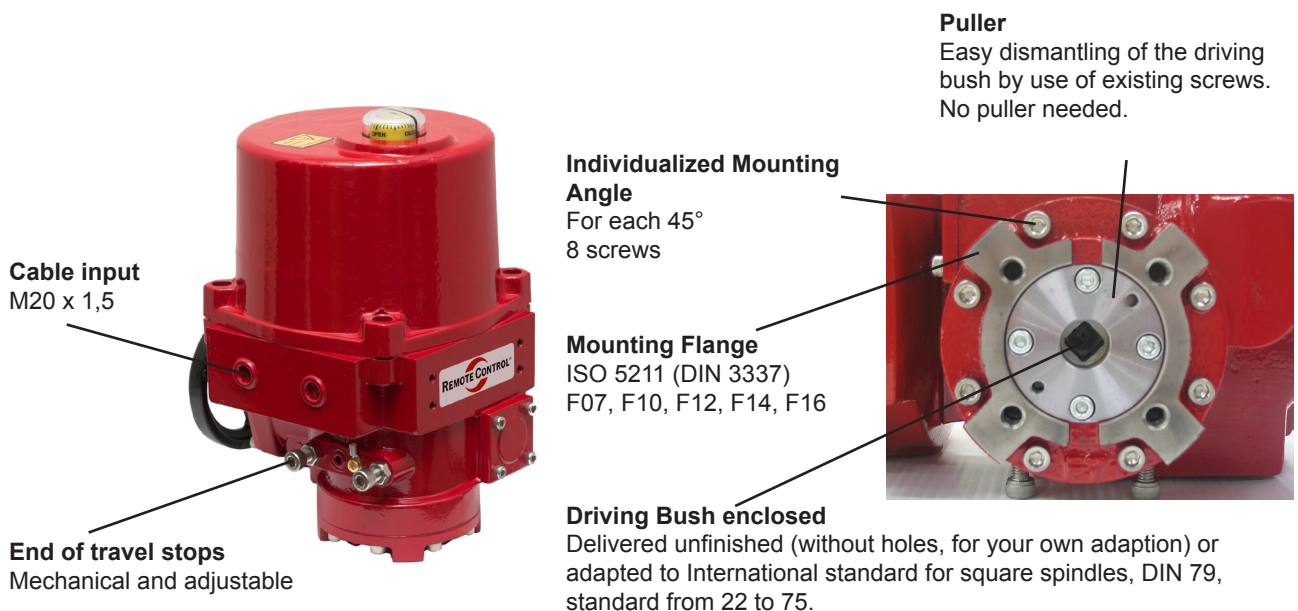
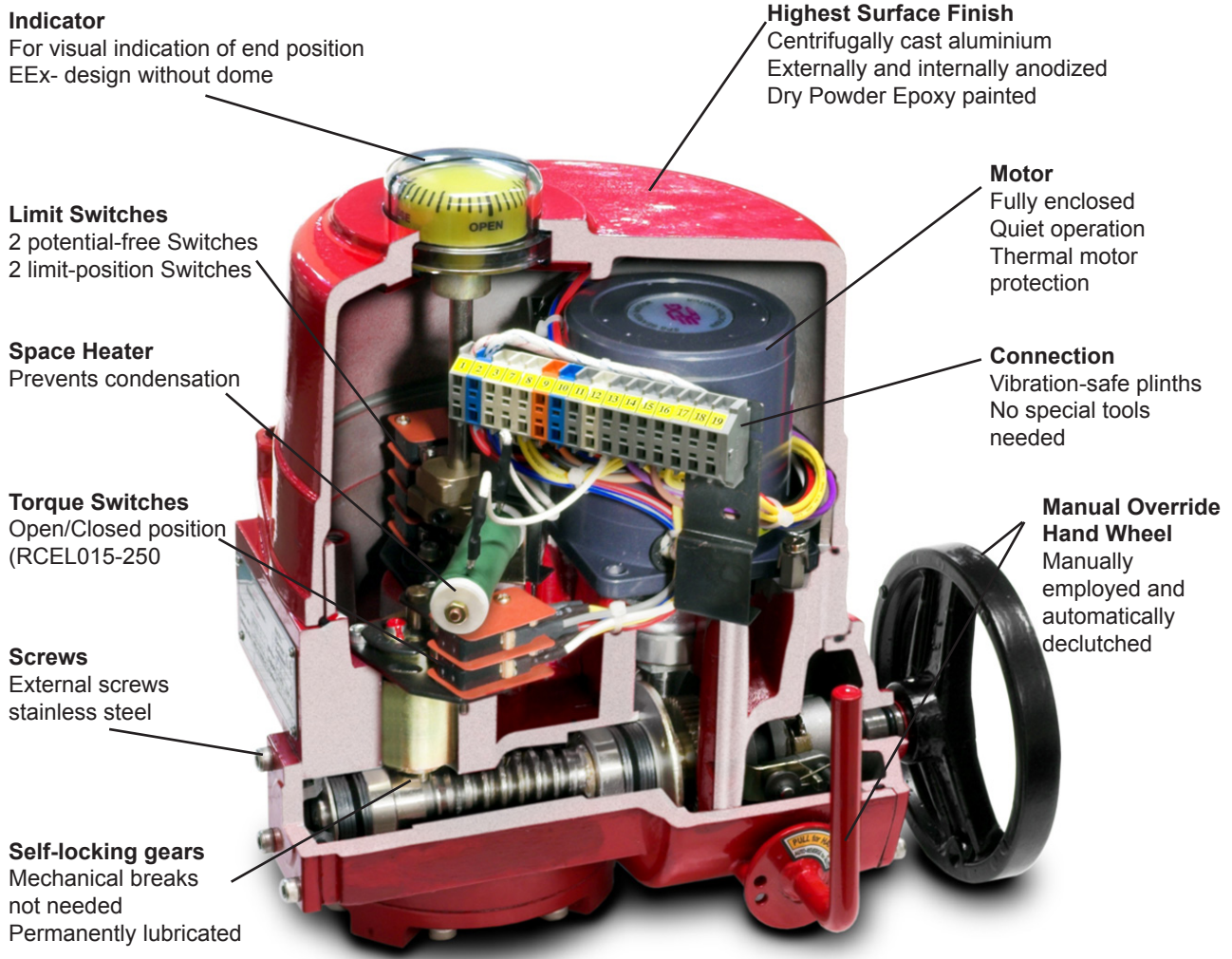

Can be adapted according to customer specification.

Dimensions RCEL005 - 005L

Type	Torque Nm	Flange ISO 5211	D Max Ø (mm)	Std hole / axle (mm)	Total height (mm)	Total width (mm)	Total depth (mm)
005	50	F03-05-07		14	148	168	132
005L	50	F03-05-07		14	208	168	132

RCEL005

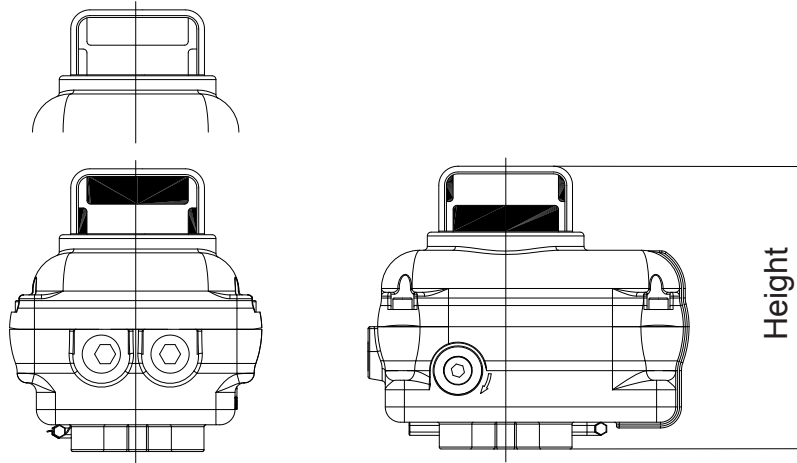

Ref 007363

RCEL005L

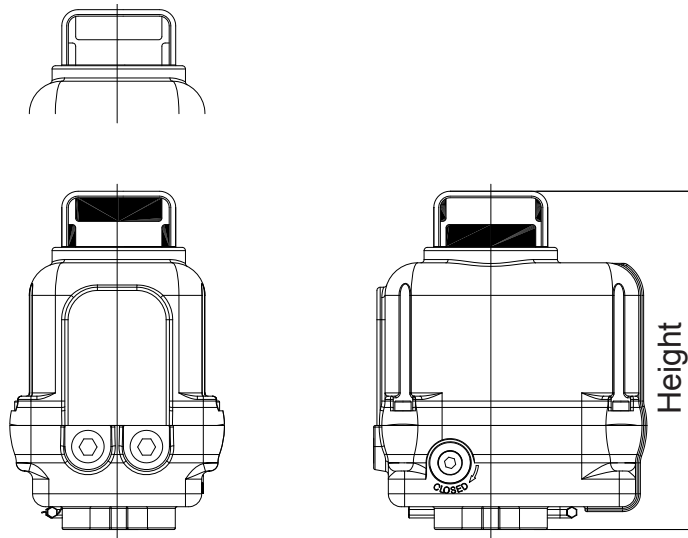

Ref 007364

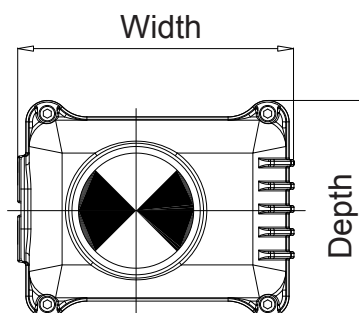

Dimensions RCEL006 - 250

Type	Torque Nm	Flange ISO 5211	D Max Ø (mm)	Std hole / axle (mm)	Total height (mm)	Total width (mm)	Total depth (mm)
RCEL 006	58	F07	22	□ 17	273	231	181
RCEL 009	88	F07	22	□ 17	273	231	181
RCEL 015	147	F07 - F10	22	□ 17	273	261	224
RCEL 019	186	F07 - F10	22	□ 17	273	261	224
RCEL 028	274	F10 - F12	32	□ 22	320	285	258
RCEL 038	373	F10 - F12	32	□ 22	320	285	258
RCEL 050	490	F10 - F12	32	□ 22	320	285	258
RCEL 060	588	F12 - F14	42	□ 27	361	325	307
RCEL 080	785	F12 - F14	42	□ 27	361	325	307
RCEL 100	981	F12 - F14	42	□ 27	361	325	307
RCEL 150	1471	F14 - F16	75	□ 36	556	388	318
RCEL 200	1962	F14 - F16	75	□ 36	556	388	318
RCEL 250	2452	F14 - F16	75	□ 36	556	388	318

RCEL006-100

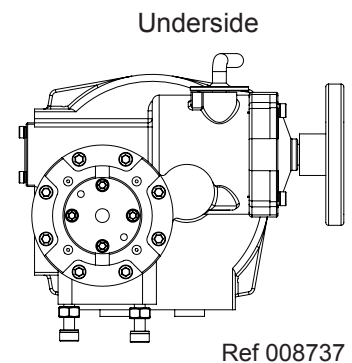
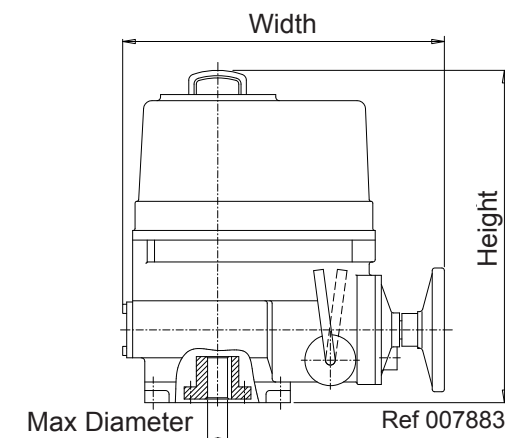
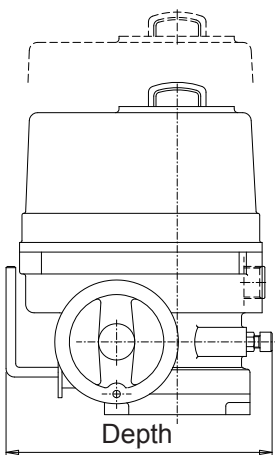

RCEL150-250

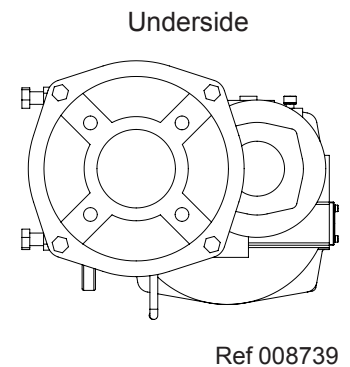
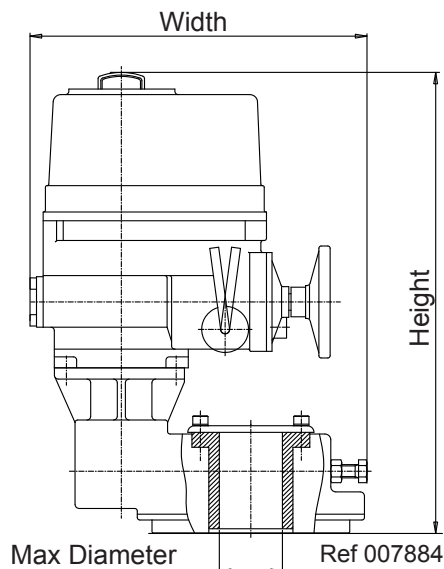
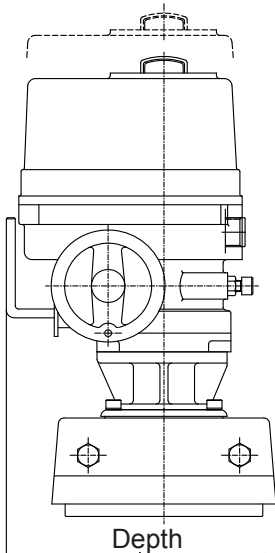

Accessories

Adaptation

A driving bush is delivered as a standard with all actuators, for customers own adaptation or adapted as below.

RCEL 005-005L:	14 mm, ISO 5211 and DIN 79
RCEL 006-019:	22 mm, DIN 79
RCEL 028-050:	32 mm, DIN 79
RCEL 060-100:	42 mm, DIN 79
RCEL 150-250:	75 mm, DIN 79

Rotork Sweden has blueprints of more than 6,000 different valves for manufacturing valve adaption kits. Rotork Sweden also offers adapted driving bushes according to customer requirements.



Mounting kit, console and driving bush

When direct mounting is not possible.

Standard design according to ISO 5211 and DIN 3337. Measurements F07, F10, F12, F14, F16.

Individually adapted to valves according to customer specifications.



Mounting actuator on valve

Rotork Sweden offers mounting of the actuator onto the valve. The complete unit is calibrated and test run prior to delivery.



PIU. Potentiometer kit

For modulating actuators.

Continually monitors the actuator position throughout the full rotation motion. PIU is built into the actuator at factory. Can also be mounted later.

Available to RCEL005L, RCEL006-250 and EEx-actuators. Mounting details are enclosed.



Operating panel

Customized control panel.



Accessories

CPT. Continuous Position Transmitter

For externally controlled actuators.

4 - 20 mA, 0 - 1 k Ω , R/I converter.

Safety Class IP 67.

RCEL005L: To be ordered as a complete unit.

RCEL006-009: CPT built into the PCU housing.

RCEL015-250: CPT built into the actuator.

Not for EEx-actuators.



PCU PB90. Position Control Unit for RCEL 006-250.

4 - 20 mA or 0 - 10 V input signal; split range.

Return signal 4 - 20 mA. Max load 300 Ω .

Safety Class IP 67.

For 3-phase 380/400/440V:

RCEL006-019: PCU PB90 built into the PCU housing.

RCEL028-250: PCU PB90 built into the actuator.

For 24VDC:

RCEL006-019: PCU PB90 built into the PCU housing.

RCEL028: PCU PB90 built into the actuator.

Not for EEx-actuators.



LCU. Local Control Unit for RCEL005L

Integrated in the actuator cover.

Lockable 3-position selector knob for Remote - Stop - Local.

3-position control knob for Open - Stop - Close.

Safety Class IP67.

For On-Off applications.

Not for retro fitting on installed actuators.

Not for Ex-protected actuators.



LCU4 & 5. Local Control Unit for RCEL006-250

Compact epoxy painted aluminium housing.

Lockable 3-position selector knob for Remote - Stop - Local.

3-position control knob for Open - Stop - Close.

LED indicators for Remote - Local - Open - Over Torque - Closed.

Built in anti-condensation space heater.

Safety Class IP67.

LCU 4 for On-Off applications.

LCU 5 for control applications.

For actuator mounting or wall mounting.

Not for Ex-protected actuators.



LCU6 Ex-proof Local Control Unit for RCEL015 -250

Epoxy painted aluminium housing.

Lockable 3-position selector knob for Remote - Stop - Local.

Push buttons for Open - Stop - Close.

LED indicators for Remote - Local - Open - Over Torque - Closed.

LCD display.

Built in self diagnostic.

Built in anti-condensation space heater.

Safety Class IP67.

ExdIIBT4 -20 $^{\circ}$ C - +55 $^{\circ}$ C.

Available for On-Off, On-Off with position feed-back signal or Control applications.

Not for retro fitting on installed actuators.

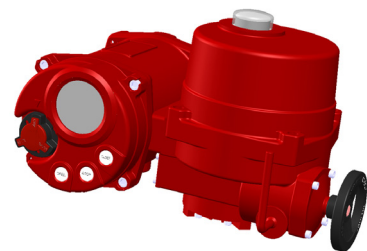

Accessories

PCU DHC-100D. Digital modulating card.

Resolution: 450 points per 90° movement.

Is mounted in the actuator at delivery if requested, can also easily be mounted later.

Input signal: 4 - 20 mA, 0 - 5V and 0 - 10V.

Easily calibrated with buttons on the front panel.

Simple configuration of all parameters.

Optional rotation direction.

Adaptable control function continually modulating the load of the electric actuator.

Safety function for overloading (detection).

Faulty signal indicated by flashing LED.

Eliminates overload through operation-time protection.

Programmable function wrong input signal open, stop or close.

Can be combined with transmitter type OTX-100 or OTR-100 for return signal 4 - 20 mA.

For 1-phase 230 V, not for EEx-actuators or actuator RCEL005 with low cover.

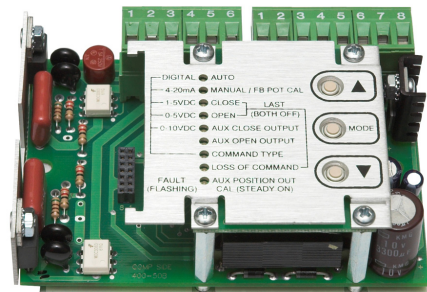

OTX-100. Transmitter for return signal.

Return signal: 4 - 20 mA.

Simple installation. Plugged directly into PCU DHC-100D.

Eliminates extra wiring. Easily calibrated with buttons on the PCU DHC-100D.

Voltage or current output can be adjusted to optional range within 0 - 10 V DC with steps of 0,0016 V or within 0 - 20 mA with steps of 0,0031 mA.

OTX-100 can be mounted at a later point in time.

For 1-phase 230 V, not for EEx-actuators.

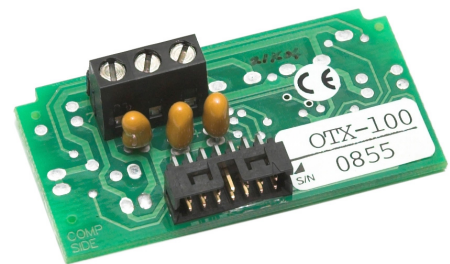

OTR-100. Transmitter for return signal and faulty information.

Return signal: 4 - 20 mA.

Simple installation. Plugged directly into PCU DHC-100D.

Eliminates extra wiring. Easily calibrated with buttons on the PCU DHC-100D.

Voltage or current output can be adjusted to optimal range within 0 - 10 V DC with steps of 0,0016 V or within 0 - 20 mA with steps of 0,0031 mA.

Relay outputs, 2 pcs programmable + 1 pc for faulty function alarm.

OTR-100 can be mounted at a later point in time.

For 1-phase 230 V, not for EEx-actuators.

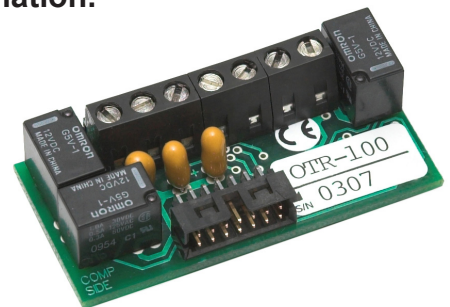

AMM-100. Manual Override Module.

Makes it possible to combine Local Control Unit type LCU5 with Position Control Unit PCU DHC-100D.

Simple installation. 2-thread communication.

Can be combined with push buttons or handle.

AMM-100 can be mounted at a later point in time.

For 1-phase 230 V, not for EEx-actuators.



Advantages with RCEL actuators from Rotork Sweden

- Strength:** “Power Start” delivers higher torque during the start.
Consultation worldwide.
Technical support from specialists, and direct customer support.
Service / spare parts from factory.
Training in the factory or at the customer’s location.
- Safety:** CE labelled.
Approval CSA –UL.
ATEX (option). RCEL006-250.
Self locking gear.
Manual override wheel in case of power loss. (RCEL006-250)
Allen key for manual operation. (RCEL005-005L)
4 Limit Switches as standard, of which 2 pcs are potential free.
Thermal motor protection. (Not for 24VDC).
Mechanical end of travel stops.
Vibration-safe plinths
- Delivery:** Fast deliveries from warehouse in Falun, Sweden.
Delivery inspection of all Actuators.
Unattached Actuators have basic settings at delivery.
Actuators mounted on valves are calibrated before delivery.
- Warranty:** 1 year warranty.
- Mounting:** Compact dimensions on the Actuators.
Remote Control has blueprints for the manufacturing of more than 6000 different valve adaption kits.
Customer adapted special applications.
Mounting Kits: International standard ISO 5211, DIN 79 and DIN 3337.
- Material Quality:** Centrifugally cast aluminium.
Exterior and interior anodized.
Dry powder painted.
Fully enclosed, low noise motor.
Built-in heater preventing condensation.
Stainless steel.

QUALITY - RELIABILITY - STRENGTH

Quality

Rotork Sweden AB is certified according to ISO 9001 and ISO 14001.

All Rotork Sweden electric actuators are manufactured under rigorous quality control.

The RCEL-actuators comply with all International standard demands.

All products are CE-labeled and manufactured according to EMC and the ATEX-directive.

The recognized high quality of RCEL's Actuators safeguards Actuators of Highest Class to our customers.

Reliability

The design is simple and robust. We only use material of the highest quality in manufacturing, which results in Actuators with high life expectancy.

Strength

RCEL Actuators are strong and unique. The secret lies in the "Power Start" which gives an increased torque during the start-up mode, exactly when the valve needs the most force.

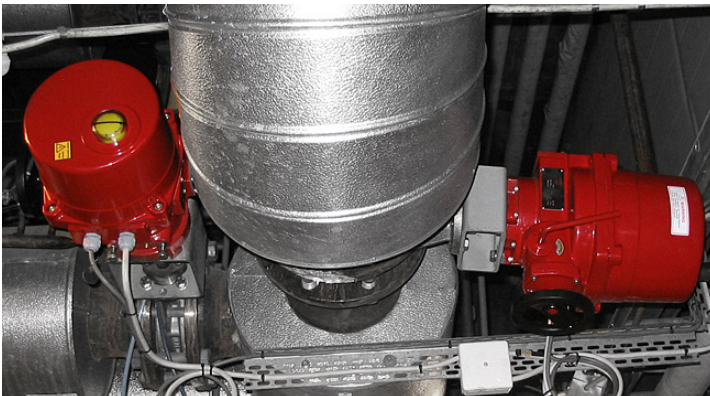
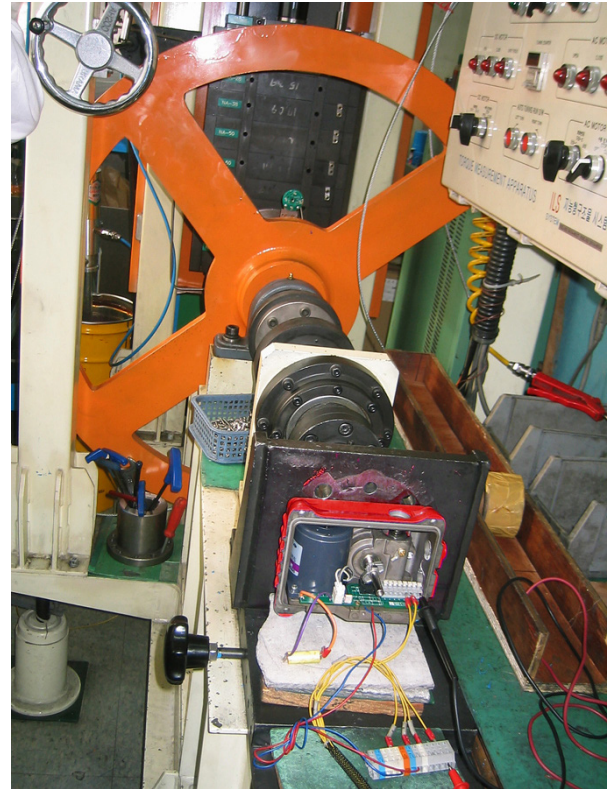

Packing & Delivery

Rotork Sweden AB's quality system ISO 9001 also encompasses packing and delivery.



**DECLARATION
OF CONFORMITY**

Module A1 (RC099, RCG100)
The Pressure Equipment Directive, 2014/68/EU

Manufacturer:
Rotork Sweden AB
Kontrollvägen 15, SE-791 45 FALUN
SWEDEN

CE-marking according to the
Pressure Equipment Directive
PED 2014/68/EU

**Svensk Certifiering Norden
Management System Certificate**

Certifikat Nr / Certificate No: 14001-0154

Utteland till
Sverige

Rotork Sweden AB

Falun, Sverige

Svensk Certifiering Norden AB intygar härmed att ledningssystemet har
granskats och uppfyller kraven i:

Svensk Certifiering Norden AB certifierar att ledningssystemet har been reviewed and complies with:

Environment Control
ISO 14001:2004

ROTORK SWEDEN AB

Kontrollvägen, 15-791 45 FALUN - SWEDEN

This certificate is part of the multi-site certificate No. 172324293UK issued
to ROTORK FLUID SYSTEMS SPS.

Bureau Veritas Certification Holding SAS - UK Branch certify that the Management System of
the above organization has been audited and found to be in accordance with the requirements
of the management system standards listed below.

Bureau Veritas Italia also certify that the Management System of the
above organization has been audited and found to be in accordance
with the requirements of the management system standards detailed below.

Standard

Quality Assurance
ISO 9001:2015

**DECLARATION
OF CONFORMITY**

ATEX Directive, 2014/34/EU

Supplier:

Rotork Sweden AB
Kontrollvägen 15, SE-791 45 FALUN
SWEDEN

Products:

NA600 / RCE1000, NA630 / RCE1030, NA610 / RCE1010, NA615 / RCE1015, NA619 / RCE1019,
NA620 / RCE1020, NA630 / RCE1030, NA650 / RCE1050, NA660 / RCE1060,
NA680 / RCE1080, NA6100 / RCE1100

CE-marking according to
ATEX Directive 2014/34/EU

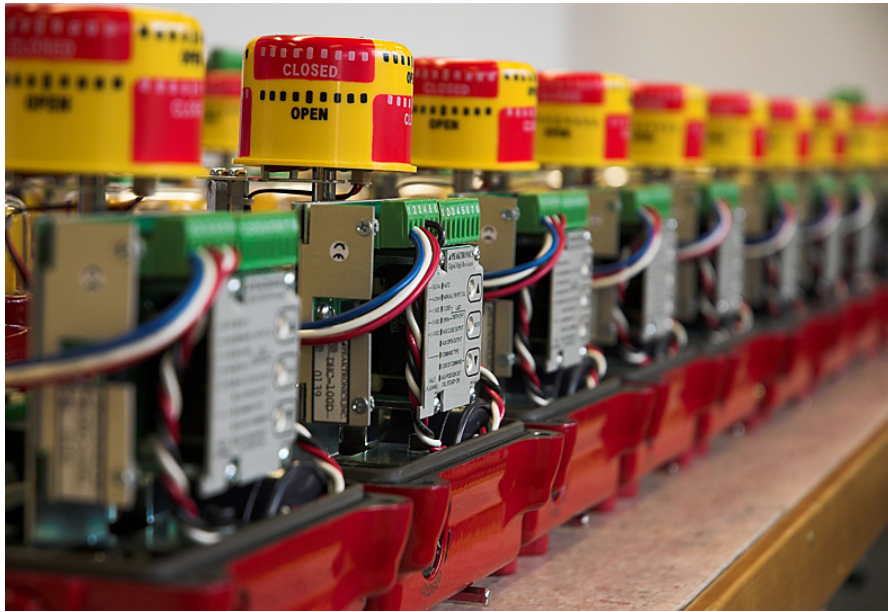

RCEL 005
Electric Actuator
50 Nm
mounted on Valve



RCEL 006-250
Electric Actuator
58 Nm to 2,450 Nm
mounted on Valve



RCE-SR
Electric Actuator
with spring return
mounted on Valve