

# MODEL 1164

## BACK PRESSURE / RELIEF REGULATOR

### SECTION I

#### I. DESCRIPTION AND SCOPE

The Model 1164 is a modulating back pressure relief regulator used to control upstream (inlet) pressure. Sizes are 3/4", 1", 1-1/2" and 2" (DN 20, 25, 40 and 50) for side (inlet, flow-through,) and bottom (discharge) connections. With proper trim utilization the unit is suitable for liquid, gaseous, or steam service. Refer to Technical Bulletin 1164-TB for design conditions and selection recommendations.

### ⚠ CAUTION

**This is not a safety device and must not be substituted for a code approved pressure safety relief valve or a rupture disc.**

### SECTION II

#### II. INSTALLATION

1. An inlet block valve should always be installed.
2. If service application is continuous such that shutdown is not readily accomplished, it is recommended that an inlet block valve, outlet block valve, and a manual bypass valve be installed.
3. Pipe unions should be installed to allow removal from piping.
4. An inlet pressure gauge should be located approximately ten pipe diameters upstream and within sight. An outlet pressure gauge is optional.
5. All installations should include an upstream relief device if the inlet pressure could exceed the pressure rating of any equipment or the maximum inlet pressure rating of the unit.

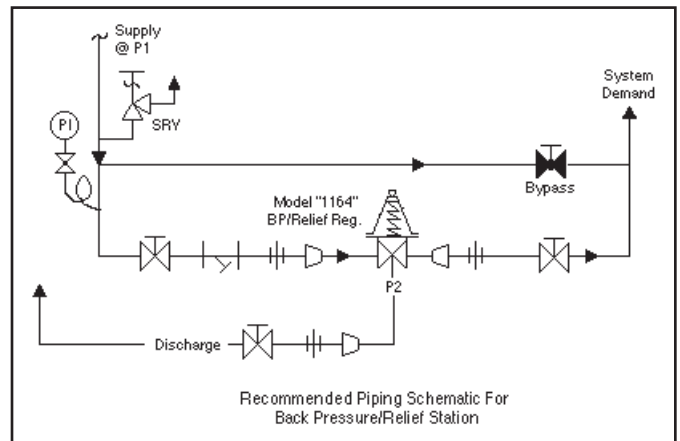

7. In placing thread sealant on pipe ends prior to engagement, ensure that excess material is removed and not allowed to enter the regulator upon startup.
8. Flow Direction: Install so the flow direction matches the arrow cast on the body. Connect the inlet pressure to the body side connection(s). Fluid will relieve out of the bottom connection. The double inlet connections are for in-line installation (plug one side connection if in-line installation is not required).

### ⚠ WARNING

**The maximum inlet pressure is equal to 1.5 times the larger number of the stated range spring on the nameplate, and is the recommended "upper operative limit" for the sensing diaphragm. Higher pressures could damage the diaphragm. (Field hydrostatic tests frequently destroy diaphragms. DO NOT HYDROSTATIC TEST THRU AN INSTALLED UNIT; ISOLATE FROM TEST.)**

6. Clean the piping of all foreign material including chips, welding scale, oil, grease and dirt before installing the regulator. Strainers are recommended.

### ⚠ CAUTION

**Installation of adequate overpressure protection is recommended to protect the regulator from overpressure and all downstream equipment from damage in the event of regulator failure.**



## CAUTION

**For welded installations, all internal trim parts, seals and diaphragm(s) must be removed from regulator body prior to welding into pipeline. The heat of fusion welding will damage non-metallic parts if not removed. NOTE: This does not apply to units equipped with extended pipe nipples.**

9. Regulator may be installed in a vertical or horizontal pipe. If it is a steam system, assure the piping is properly trapped and oriented.
10. Regulator may be rotated around the pipe axis 360°. Recommended positions are with spring

chamber vertical upwards, or horizontal. Orient such that the spring chamber vent hole does not collect rainwater or debris.

11. Regulators are not to be direct buried underground.
12. For insulated piping systems, recommendation is to not insulate regulator.
13. Spring Chamber Vent Tap - Option 1164-25: 1/4" NPT Vent. Leave connection vented to atmosphere or pipe to outside or sump (the later if fluid through valve is toxic or could present a hazard) depending on the application and the controlled fluid.

## SECTION III

### III. PRINCIPLE OF OPERATION

1. Movement occurs as pressure variations register on the diaphragm. The registering pressure is the inlet,  $P_1$  or upstream pressure. The range spring opposes diaphragm movement. As inlet pressure drops, the range spring pushes the diaphragm down, closing the port; as inlet pressure increases, the diaphragm pushes up and the port opens.
2. A complete diaphragm failure may cause the valve to fail closed. A cracked metal diaphragm will leak fluid through the vent hole of the spring chamber, but will continue to operate.

## SECTION IV

### IV. STARTUP

1. Start with the block valves closed. A bypass valve may be used to maintain system pressure without changing the following steps.
2. Relax the range spring by turning the adjusting screw counterclockwise (CCW) a minimum of three (3) full revolutions. This reduces the inlet (upstream) pressure set point.
3. If it is a "hot" piping system, and equipped with a bypass valve, slowly open the bypass valve to pre-heat the system piping and to allow slow expansion of the piping. Assure proper steam trap operation if installed. Closely monitor inlet (upstream) pressure, via gauge, to assure not over-pressurizing. NOTE: If no bypass valve is installed, extra caution should be used in starting up a cold system; i.e. do everything slowly.
4. Crack open the inlet (upstream) block valve.
5. Slowly open the outlet (downstream) block valve observing the inlet (upstream) pressure gauge. Determine if the regulator is flowing. If not, slowly rotate the regulator adjusting screw counterclockwise (CCW) until flow begins.
6. Continue to slowly open the outlet (downstream) block valve until fully open.
7. Observing the inlet (upstream) pressure gauge, rotate the adjusting screw clockwise (CW) slowly until the inlet pressure begins to rise. Rotate CW until the desired setpoint is reached.
8. Continue to slowly open the inlet (upstream) block valve. If the inlet (upstream) pressure exceeds the desired setpoint pressure, rotate the adjusting screw CCW until the pressure decreases.
9. When flow is established steady enough that both the outlet and inlet block valves are fully open, begin to slowly close the bypass valve if installed.
10. Develop system flow to a level near its expected normal rate, and reset the regulator setpoint by turning the adjusting screw CW to increase inlet pressure, or CCW to reduce inlet pressure.
11. Reduce system flow to a minimum level and observe setpoint. Inlet pressure will rise from the setpoint of Step 9. (Ensure that this rise does not exceed the stated upper limit of the range spring by greater than 50%; i.e. 30-80 psig (2.07-5.52 Barg) range spring, at maximum flow the inlet pressure should not exceed 1.5 x 80 psig (5.6 Barg), or 120 psig (8.3 Barg). If it does, consult factory.)
12. Increase flow to maximum level if possible. Inlet (upstream or  $P_1$ ) pressure should fall off. Readjust setpoint as necessary at the normal flow rate.

## SECTION V

### V. SHUTDOWN

1. On systems with a bypass valve, and where system pressure is to be maintained as the regulator is shut down, slowly open the bypass valve while closing the inlet (upstream) block valve. Fully close the inlet (upstream) block valve. (When on bypass, the system pressure must be constantly observed and manually regulated.) Close the outlet (downstream) block valve.

#### CAUTION

**Do not walk away and leave a bypassed regulator unattended.**

2. If the regulator and system are both to be shutdown, slowly close the inlet (upstream) block valve. Close the outlet (downstream) valve only if regulator removal is required.

## SECTION VI

### VI. MAINTENANCE

#### WARNING

**SYSTEM UNDER PRESSURE. Prior to performing any maintenance, isolate the regulator from the system and relieve all pressure. Failure to do so could result in personal injury.**

#### A. General:

1. Maintenance procedures hereinafter are based upon removal of the regulator from the pipeline where installed.
2. Owner should refer to owner's procedures for removal, handling, cleaning and disposal of non-reusable parts, i.e. asbestos gaskets, etc.
3. Refer to Figure 1 for basic regulator construction. For a blow-up of the TFE seat trim, see Figure 2.

#### WARNING

**SPRING UNDER COMPRESSION. Prior to removing spring chamber, relieve spring compression by backing out the adjusting screw. Failure to do so may result in flying parts that could cause personal injury.**

#### B. Diaphragm Replacement:

1. Securely install the body (1) in a vise with the spring chamber (2) directed upwards.
2. Relax range spring (3) by turning adjusting screw (17) CCW until removed from spring chamber (2).
3. Draw or embed a match mark between body casting (1) and spring chamber casting (2) along flanged area.
4. Remove all diaphragm flange nuts (14) and bolts (13).

#### CAUTION

**When reassembling, the spring (7) will be under compression. Center all internal parts before placing the spring chamber.**

5. Remove spring chamber (2), range spring (3) and spring button (4).
6. Remove pressure plate (5) and inspect to ensure no deformation due to over-pressurization. If deformed, replace.
7. Remove diaphragm (9), diaphragm gasket (10), and O-ring (11).
8. Clean body (1) and diaphragm flange. **NOTE:** *On valves originally supplied as "special cleaned", option 1164-55, maintenance must include a level of cleanliness equal to Cashco's cleaning standard #S-1134. Contact factory for details.*
9. Install new O-ring (11), diaphragm gasket (10), and diaphragm. Apply a light coat of gasket sealant.
10. Center pressure plate (5) on diaphragm (9). Place the range spring (3) on to the retainer hub of the pressure plate (5).
11. Place multi-purpose, high temperature grease into depression of spring button (4) where adjusting screw bears. Set spring button (4) onto range spring (3); ensure spring button (4) is laying flat.
12. Aligning the match marks, place spring chamber (2) over the above stacked parts. Apply pressure (manually) to the spring chamber (2) from opposite sides to compress the spring (7), so bolting can be started from opposite sides. Install all bolts (13) and nuts (14) by hand tightening. Mechanically tighten

bolting (13 & 14) in a cross pattern that allows spring chamber (2) to be pulled down evenly. Recommended torques are as follows:

Regulator Size	Bolt Size	Metal Dia-phragm
3/4" - 1" (DN20,25)	3/8" - 24	30 ft/lbs.
1-1/2" (DN40)	7/16" - 20	45 ft/lbs.
2" (DN50)	1/2" - 20	70 ft/lbs.

**NOTE:** Never replace bolting (13 & 14) with just any bolting if lost. Bolt heads and nuts are marked with specification identification numbers. Use only proper grades as replacements.

13. Reinstall adjusting screw (17) with locknut (8).
14. Soap solution test around bolting (13 & 14) and body (1) and spring chamber (2) flanges for leakage. Ensure that an inlet pressure is maintained during this leak test of at least mid-range level; i.e. 30-80 psig (2.07-5.52 Barg) range spring, 60 psig (4.14 Barg) test pressure minimum.

#### C. Trim Replacement (For Metal Seated Units):

1. Trim removal requires that the diaphragm be removed. Refer to previous procedure Section VI., Sub-section B, Steps 1 through 8.
2. Remove valve guide (12), valve plug (16) and spring (7).
3. Inspect seating surface of integral seat ring (15). If seat ring shows erosion or wear, the regulator should be replaced.
4. Inspect guide (12), plug (16), O-ring (11) and spring (7). Inspect parts for excessive wear. Replace if worn, nicked or depressed.

5. Clean the body (1) cavity. Clean all parts to be reused. **NOTE:** On regulators originally supplied with Option 1164-55, "special cleaned", maintenance must include a level of cleanliness equal to Cashco's cleaning standard #S-1134. Contact factory for details.
6. Reinstall the spring (7). Then place the O-ring (11) on the plug (16) and the plug (16) into the valve guide (12).
7. Now place the valve guide (12) (along with the O-ring (11) and plug (16)) on to the spring (7).
8. Reinstall diaphragm (9) per Section VI., Sub-section B., Steps 9 through 14.
9. Bench test unit for suitable operation. **NOTE:** Regulators are not tight shutoff devices. Even if pressure falls below setpoint, a regulator may or may not develop bubble tight shutoff. In general, tighter shutoff can be expected with composition seat.
10. Soap solution test around body (1) flange for leakage. Test pressure should be the maximum allowed.

#### D. Trim Replacement (For TFE Seated Units):

1. Follow same steps as listed under "Trim Replacement - Metal Seated Units" except for the following guidelines:
2. When inspecting parts for excessive wear (VI.C.4), ensure there are no foreign particles embedded or nicks in the TFE seat which is an integral part of the plug assembly. Replace plug assembly (16) if any of these conditions are noted.

## SECTION VII

### VII. TROUBLE SHOOTING GUIDE

1. Erratic Operation; chattering.

Possible Causes	Remedies
A. Oversized regulator.	A1. Check actual flow conditions, resize regulator for minimum and maximum flow. Tighten flange bolting. A2. Increase flow rate. A3. Decrease regulator pressure drop; decrease inlet pressure by placing a throttling orifice in inlet piping union. A4. Install next step higher range spring. A5. Before replacing regulator, contact factory.
B. Inadequate Rangeability.	B1. Increase flow rate. B2. Decrease regulator pressure drop. B3. Install next step higher range spring. Contact factory.

2. Regulator inlet (upstream) pressure too high.

Possible Causes	Remedies
A. Regulator undersized.	A1. Confirm by opening bypass valve together with regulator. A2. Check actual flow conditions, resize regulator; if regulator has inadequate capacity, replace with larger unit.
B. Incorrect range spring (screwing out CCW of adjusting screw does not allow bringing pressure level to a stable and proper level).	B.1 Replace range spring with proper lower range. B.2 Contact factory.
C. Too much build.	C1. Review build expected. C2. Contact factory.
D. Restricted diaphragm movement.	D. Ensure no moisture in spring chamber at temperatures below freeze point. Ensure no dust or debris entering vent opening. If rainwater or debris can enter, reorient spring chamber.

3. Excessive seat leakage.

Possible Causes	Remedies
A. Foreign matter on the seating surface, erosion of the seating surface or foreign matter on plug balancing O-ring.	A. Clean or replace plug assembly (TFE seat). For metal replace regulator if integral seat is damaged. Replace plug and O-ring.

4. Leakage through the spring chamber vent hole.

Possible Causes	Remedies
A. Normal-life diaphragm failure.	A. Replace diaphragm.
B. Abnormal short-life diaphragm failure.	B1. Can be caused by excessive chattering. See No. 1. to remedy chatter. B2. Can be caused by corrosive action. Consider alternate diaphragm material. B3. Upstream (inlet) pressure build-up occurring that over-stresses diaphragms. Relocate regulator or protect with safety relief valve.

5. Sluggish operation.

Possible Causes	Remedies
A. Plugged spring chamber vent.	A. Clean vent opening.
B. Fluid too viscous.	B. Heat fluid. Contact factory.
C. Broken spring.	C. Replace spring.

## SECTION VIII

### VIII. ORDERING INFORMATION NEW REPLACEMENT UNIT vs PARTS "KIT" FOR FIELD REPAIR

To obtain a quotation or place an order, please retrieve the Serial Number and Product Code that was stamped on the metal name plate and attached to the unit. This information can also be found on the Bill of Material ("BOM"), a parts list that was provided when unit was originally shipped. (Serial Number typically 6 digits). Product Code typical format as follows: (last digit is alpha character that reflects revision level for the product).

□□□ - □□□ 7 - □□□□□□□□□□

#### **NEW REPLACEMENT UNIT:**

Contact your local Cashco, Inc., Sales Representative with the Serial Number and Product code. With this information they can provide a quotation for a new unit including a complete description, price and availability.



#### **CAUTION**

**Do not attempt to alter the original construction of any unit without assistance and approval from the factory. All purposed changes will require a new name plate with appropriate ratings and new product code to accommodate the recommended part(s) changes.**

#### **PARTS "KIT" for FIELD REPAIR:**

Contact your local Cashco, Inc., Sales Representative with the Serial Number and Product code. Identify the parts and the quantity required to repair the unit from the "BOM" sheet that was provided when unit was originally shipped.

**NOTE:** *Those part numbers that have a quantity indicated under "Spare Parts" in column "A" reflect minimum parts required for inspection and rebuild, - "Soft Goods Kit". Those in column "B" include minimum trim replacement parts needed plus those "Soft Goods" parts from column "A".*

If the "BOM" is not available, refer to the cross-sectional drawings included in this manual for part identification and selection.

A Local Sales Representative will provide quotation for appropriate Kit Number, Price and Availability.

The contents of this publication are presented for informational purposes only, and while every effort has been made to ensure their accuracy, they are not to be construed as warranties or guarantees, express or implied, regarding the products or services described herein or their use or applicability. We reserve the right to modify or improve the designs or specifications of such product at any time without notice. Cashco, Inc. does not assume responsibility for the selection, use or maintenance of any product. Responsibility for proper selection, use and maintenance of any Cashco, Inc. product remains solely with the purchaser.



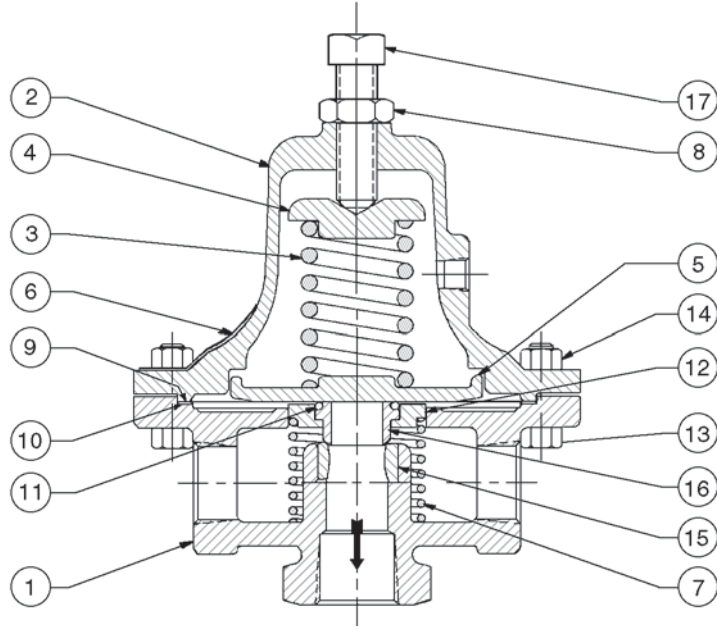

**Figure 1**  
Basic Model 1164  
Metal Seat Construction

<u>Item No.</u>	<u>Description</u>
1	Body
2	Spring Chamber
3	Range Spring
4	Spring Button
5	Pressure Plate
6	Name Plate
7	Spring
8	Adjusting Screw Lock Nut
9	Diaphragm
10	Diaphragm Gasket
11	O-Ring
12	Valve Guide
13	Cap Screw (Flange Bolting)
14	Nut (Flange Bolting)
15	Valve Seat
16	Valve Plug or Valve Plug Subassembly
17	Adjusting Screw

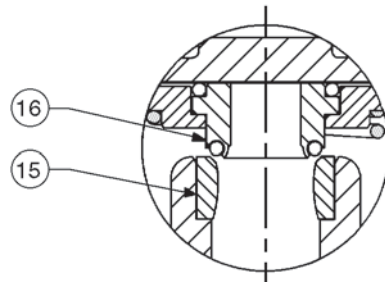

**Figure 2**  
Composition Seat

## ATEX 94/9/EC: Explosive Atmospheres and Cashco Inc. Regulators

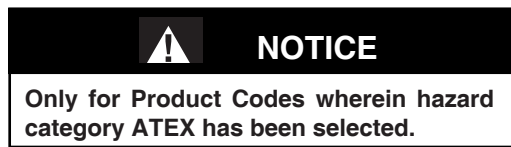

These valves satisfy the safety conditions according to EN 13463-1 and EN 13463-5 for equipment group IIG 2 c.

Caution: Because the actual maximum temperature depends not on the equipment itself, but upon the fluid temperature, a single temperature class or temperature cannot be marked by the manufacturer.

Specific Precaution to Installer: Electrical grounding of valve must occur to minimize risk of effective electrical discharges.

Specific Precaution to Installer: Atmosphere vent holes should be plugged to further minimize the risk of explosion.

Specific Precaution to Maintenance: The Valve Body/ Housing must be regularly cleaned to prevent buildup of dust deposits.

Specific Precaution to Maintenance: Conduct periodic Continuity Check between Valve Body/ Housing and Tank to minimize risk of electrical discharges.

Attention: When repairing or altering explosion-protected equipment, national regulations must be adhered to. For maintenance and repairs involving parts, use only manufacturer's original parts.

ATEX requires that all components and equipment be evaluated. Cashco pressure regulators are considered components. Based on the ATEX Directive, Cashco considers the location where the pressure regulators are installed to be classified Equipment-group II, Category 3 because flammable gases would only be present for a short period of time in the event of a leak. It is possible that the location could be classified Equipment-group II, Category 2 if a leak is likely to occur. Please note that the system owner, not Cashco, is responsible for determining the classification of a particular installation.

### Product Assessment

Cashco performed a conformity assessment and risk analysis of its pressure regulator and control valve models and their common options, with respect to the Essential Health and Safety Requirements in Annex II of the ATEX directive. The details of the assessment in terms of the individual Essential Health and Safety Requirements, are listed in Table 1. Table 2 lists all of the models and options that were evaluated and along with their evaluation.

Models and options not listed in Table 2 should be assumed to not have been evaluated and therefore should not be selected for use in a potentially explosive environment until they have been evaluated.

Standard default options for each listed model were evaluated even if they were not explicitly listed as a separate option in the table. Not all options listed in the tables are available to all models listed in the tables. Individual TB's must be referenced for actual options.

When specifying a regulator that is to be used in a potentially explosive environment one must review the evaluations in Table 1 and 2 for the specific model and each and every option that is being specified, in order to determine the complete assessment for the unit.

A summary of the models and options found to have an impact on ATEX assessment due to potential ignition sources or other concerns from the ATEX Essential Health and Safety Requirements, are listed below.

1. The plastic knob used as standard on some models, (P1, P2, P3, P4, P5, P7, 3381, 4381, 1171, and 2171) is a potential ignition source due to static electricity. To demonstrate otherwise, the knob must be tested to determine if a transferred charge is below the acceptable values in IEC 60079-0 Section 26.14 (See items 25, 27, and 28 in Appendix A). Until the plastic knob has been shown to be acceptable, then either the metal knob option, or a preset outlet pressure option is required to eliminate this ignition source (See items 45 and 64 in Tables).
2. The pressure gauges offered as options on a few of the regulator models (DA's, P1-7, D, 764, 521), use a plastic polycarbonate window that is a potential ignition source due to static electricity. To demonstrate that the gauges are not a potential source of ignition, the gauges would need to be tested to determine if a transferred charge is below the acceptable values in IEC 60079-0 Section 26.14 or the pressure gauge supplier must provide documentation indicating the gauge is compliant with the ATEX Directive (See items 26, 27, and 28 in Appendix A). Until compliance is determined, regulators should not be ordered with pressure gauges for use in potentially explosive environments.



3. Tied diaphragm regulators with outlet ranges greater than 100 psig should be preset to minimize the risk that improper operation might lead to an outboard leak and a potentially explosive atmosphere (See item 6 in Table 1).
4. Regulators must be ordered with the non-relieving option (instead of the self-relieving option) if the process gas they are to be used with is hazardous (flammable, toxic, etc.). The self-relieving option vents process gas through the regulator cap directly into the atmosphere while the non-relieving option does not. Using regulator with the self-relieving option in a flammable gas system could create an explosive atmosphere in the vicinity of the regulator.
5. Regulators with customer supplied parts are to be assumed to not have been evaluated with regard to ATEX and thus are not to be used in a potentially explosive environment unless a documented evaluation for the specific customer supplied parts in question has been made. Refer to Table 1 for all models and options that have been evaluated.

## Product Usage

A summary of ATEX related usage issues that were found in the assessment are listed below.

1. Pressure regulators and control valves must be grounded (earthed) to prevent static charge build-up due to the flowing media. The regulator can be grounded through any mounting holes on the body with metal to metal contact or the system piping can be grounded and electrical continuity verified through the body metal seal connections. Grounding of the regulator should follow the same requirements for the piping system. Also see item 30 in Table 1.
2. The system designer and users must take precautions to prevent rapid system pressurization which may raise surface temperatures of system components and tubing due to adiabatic compression of the system gas.
3. Heating systems installed by the user could possibly increase the surface temperature and must be evaluated by the user for compliance with the ATEX Directive. User installation of heating systems applied to the regulator body or system piping that affects the surface temperature of the pressure regulator is outside the scope of this declaration and is the responsibility of the user.
4. The Joule-Thomson effect may cause process gases to rise in temperature as they expand going through a regulator. This could raise the external surface temperature of the regulator body and downstream piping creating a potential source of ignition. Whether the Joule-Thomson effect leads to heating or cooling of the process gas depends on the process gas and the inlet and outlet pressures. The system designer is responsible for determining whether the process gas temperature may rise under any operating conditions. If a process gas temperature rise is possible under operating conditions, then the system designer must investigate whether the regulator body and downstream piping may increase in temperature enough to create a potential source of ignition.

The process gas expansion is typically modeled as a constant enthalpy throttling process for determining the temperature change. A Mollier diagram (Pressure – Enthalpy diagram with constant temperature, density, & entropy contours) or a Temperature – Entropy diagram with constant enthalpy lines, for the process gas, can be used to determine the temperature change. Helium and hydrogen are two gases that typically increase in temperature when expanding across a regulator. Other gases may increase in temperature at sufficiently high pressures.

## Product Declaration

If the above issues are addressed by selecting options that do not have potential sources of ignition, avoiding options that have not been assessed, and by taking the proper usage issue precautions, then Cashco regulators can be considered to be a mechanical device that does not have its own source of ignition and thus falls outside the scope of the ATEX directive.

Cashco, Inc.  
P.O. Box 6  
Ellsworth, KS 67439-0006  
PH (785) 472-4461  
Fax. # (785) 472-3539  
www.cashco.com  
email: sales@cashco.com  
Printed in U.S.A. IOM-1164

Cashco GmbH  
Handwerkerstrasse 15  
15366 Hoppegarten, Germany  
PH +49 3342 30968 0  
Fax. No. +49 3342 30968 29  
www.cashco.com  
email: germany@cashco.com

Cashco do Brasil, Ltda.  
Al.Venus, 340  
Indaiatuba - Sao Paulo, Brazil  
PH +55 11 99677 7177  
Fax. No.  
www.cashco.com  
email: brazil@cashco.com