



ISO Registered Company

# MODEL 345 PRESSURE REDUCING REGULATOR

## SECTION I

### I. DESCRIPTION AND SCOPE

The Model 345 is a diaphragm-less, heavy duty, high pressure reducing regulator used to control downstream (outlet or P<sub>2</sub>) pressure. Sizes are 1/2", 3/4", 1" (DN15, 20, and 25 ). With proper trim utilization, the unit is suitable for liquid and gaseous service. Refer to Technical Bulletin 345-TB for design conditions and selection recommendations. **NOT FOR STEAM SERVICE.**

## SECTION II

### II. INSTALLATION

1. An inlet block valve should always be installed.
2. If service application is continuous such that shutdown is not readily accomplished, it is recommended that an inlet block valve, outlet block valve, and a manual bypass valve be installed.
3. Pipe unions should be installed to allow removal from piping.
4. An outlet pressure gauge should be located approximately ten pipe diameters downstream, and within sight.
5. All installations should include a downstream relief device if the inlet pressure could exceed the pressure rating of any downstream equipment or the maximum outlet pressure rating of the unit.

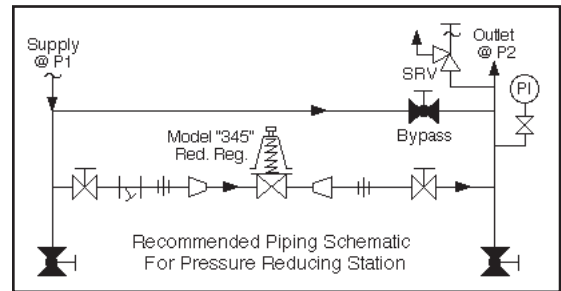

8. Flow Direction: Install so the flow direction matches the arrow cast on the main regulator body.
9. Basic Regulator - (Refer to Figure 1): Regulator may be rotated around the pipe axis 360°. Recommended position is with spring chamber vertical upwards. Orient such that the spring chamber vent hole does not collect rainwater or debris.
10. Regulators are not to be direct buried underground.



### CAUTION

**DONOT HYDROSTATIC TEST THROUGH AN INSTALLED UNIT; ISOLATE REGULATOR FROM TEST.** Internal mechanical damage could result. Refer to Technical Bulletin Model 345, Table 5 for "emergency overpressure level" that will not do irreparable damage. In addition, note on nameplate that Inlet and Outlet pressure ratings are at different levels.

6. Clean the piping of all foreign material including chips, welding scale, oil, grease and dirt before installing the regulator. Strainers are recommended.
7. In placing thread sealant on pipe ends prior to engagement, assure that excess material is removed and not allowed to enter the regulator upon startup.



### CAUTION

Installation of adequate overpressure protection is recommended to protect the regulator from overpressure and all downstream equipment from damage in the event of regulator failure.



### CAUTION

For welded installations, all internal trim parts, seals and diaphragm(s) must be removed from regulator body prior to welding into pipeline. The heat of fusion welding will damage non-metallic parts if not removed. **NOTE: This does not apply to units equipped with extended pipe nipples.**

## SECTION III

### III. PRINCIPLE OF OPERATION

Movement occurs as pressure variations register on the pressure piston. The registering pressure is the outlet,  $P_2$ , or downstream pressure. The range spring opposes pressure piston movement. As outlet pressure drops, the range spring pushes the pressure piston down, opening the port; as outlet pressure increases, the pressure piston pushes up and the port opening closes.

## SECTION IV

### IV. STARTUP

1. Start with the block valves closed. A bypass valve may be used to maintain outlet pressure in the downstream system without changing the following steps.
2. Relax the range spring by turning the T-bar handle adjusting screw counter clockwise (CCW) a minimum of three (3) full revolutions. This reduces the outlet (downstream) pressure set point.
3. If it is a "hot" piping system, and equipped with a bypass valve, slowly open the bypass valve to pre-heat the system piping and to allow slow expansion of the piping. Closely monitor outlet (downstream) pressure via gauge to assure not over-pressurizing. NOTE: If no bypass valve is installed, extra caution should be used in starting up a cold system; i.e. do everything slowly.
4. Crack open the outlet (downstream) block valve.
5. Slowly open the inlet (upstream) block valve observing the outlet (downstream) pressure gauge. Determine if the regulator is flowing. If not, slowly rotate the regulator T-bar adjusting screw handle clockwise (CW) until flow begins.
6. Continue to slowly open the inlet (upstream) block valve until fully open.
7. Continue to slowly open the outlet (downstream) block valve, especially when the downstream piping system isn't pressurized. If the outlet (downstream) pressure exceeds the desired pressure, close the block valve and go to Step 2, then return to Step 4.
8. When flow is established steady enough that the outlet (downstream) block valve is fully open, begin to slowly close the bypass valve if installed.
9. Develop system flow to a level near its expected normal rate, and reset the regulator set point by turning the T-bar adjusting screw handle CW to increase outlet pressure, or CCW to reduce outlet pressure.
10. Reduce system flow to a minimum level and observe set point. Outlet pressure will rise from the set point of Step 9. The maximum rise in outlet pressure on decreasing flow should not exceed the stated upper limit of the range spring by greater than 10%; i.e. 500 to 1000 psig (34.5 to 68.9 Barg) range spring, at low flow the outlet pressure should not exceed 1100 psig (75.8 Barg), if it does, consult factory.

## SECTION V

### V. SHUTDOWN

1. On systems with a bypass valve, and where system pressure is to be maintained as the regulator is shut down, slowly open the bypass valve while closing the inlet (upstream) block valve. Fully close the inlet (upstream) block valve. (When on bypass, the system pressure must be constantly observed and manually regulated.) Close the outlet (downstream) block valve.



#### CAUTION

**Do not walk away and leave a bypassed regulator unattended!**

2. If the regulator and system are to both be shutdown, slowly close the inlet (upstream) block valve. Close the outlet (downstream) valve only if regulator removal is required.

## SECTION VI

### VI. MAINTENANCE:

**WARNING**

**SYSTEM UNDER PRESSURE.** Prior to performing any maintenance, isolate the regulator from the system and relieve all pressure. Failure to do so could result in personal injury.

#### A. General:

1. Maintenance procedures hereinafter are based upon removal of the regulator unit from the pipeline where installed.
2. Owner should refer to owner's procedures for removal, handling, cleaning and disposal of non-reusable parts, i.e. gaskets, etc.
3. Refer to Figure 1 for the basic regulator, metal seat design and Figure 2 for a blow-up of the balanced TFE trim.

#### B. Pressure Piston/O-Ring: Inspection/ Replacement:

1. Securely install the body (1) in a vise with the spring chamber (2) directed upwards.

**WARNING**

**SPRING UNDER COMPRESSION.** Prior to removing spring chamber, relieve spring compression by backing out the T-bar adjusting screw. Failure to do so may result in flying parts that could cause personal injury.

2. Relax range spring (14) by turning T-bar adjusting screw handle (6) CCW to release spring compression.
3. Grasp hexagon portion (w/proper wrench) of the spring chamber (2) and turn CCW to remove.
4. Remove the thrust bearing (9), range spring (14), and spring button (4).
5. Pull the pressure piston (3) directly out of the body. Inspect the body quad ring (11) and body back up ring (12). If nicked or scratched, replace. Apply a light coating of lubricant to body quad ring (11) when replacing.
6. Inspect pressure piston (3) to assure no deformation due to over-pressurization. If deformed, replace.
7. Reverse steps 1 through 5 for reassembly. Make

sure spring chamber (2) is tightened fully down against body (1).

#### C. Trim Replacement (For Metal Seated Units):

1. Install body (1) in a vise with the body cap (5) on top.
2. Using a 5/16" Allen wrench, remove socket head cap screws (21). Carefully remove body cap from body.
3. Remove piston spring (17), piston (15 or 15.1), cylinder (16 or 15.2) and cylinder gasket (18). Inspect parts for excessive wear, especially at seat surfaces. Replace if worn, nicked, or depressed.
4. Remove body cap o-ring (13) and clean contacting surface of body. Clean flat mating surfaces of body (1) to body cap (5) shoulder.
5. Clean debris from within regulator body (1) cavity. Clean parts to be reused. **NOTE:** *On regulators originally supplied as "oxygen clean", option 345-55, maintenance must include a level of cleanliness equal to Cashco's cleaning standard #S-1134. Contact factory for details.*
6. Replace cylinder gasket (18) on cylinder (16 or 15.2)
7. Reinstall the cylinder (16 or 15.2) and cylinder gasket (18) into body cavity.
8. Slide the piston (15.1) slowly into place, assuring that the piston (15.1) post slides into the pressure piston (3).
9. Carefully place piston spring (17) directly on top of the piston (15.1).
10. Install body cap o-ring (13) on body cap (5) and carefully place body cap (5) into body (1). Replace socket head cap screws (21) and tighten with a 5/16" Allen wrench. Recommended torque is as follows:

Regulator Size	Cap Screw Size	Torque
1/2", 3/4" & 1" (DN15, 20, 25)	3/8"-16-1" skt.hd cap screw	50 ft./lbs. (68 N-m)

**NOTE:** *Never replace the socket head cap screws (21) with just any bolting. Use only the proper size and grade as replacement.*

11. Bench test unit for suitable operation. **NOTE:** *Regulators are not tight shutoff devices. Even if pressure builds up beyond set point, a regulator may or may not develop bubble tight shutoff. In general, tighter shutoff can be expected with composition seat.*
12. Soap test around body cap (5) and body(1) for leakage. Test pressure should be a minimum of 100 psig (6.9 Barg) at the inlet and leakage determined by bubbles.

**D. Trim Replacement** (For TFE Seated Units):

1. Follow same steps as listed under trim replacement for metal seated units, except for the following guidelines:
  - a. After removing the body cap(5) (C.2), inspect the inside surface of the body cap for scratches or nicks. These could result in leakage past the quad ring (19) and backup ring (20). If worn or scratched replace the body cap (5).
  - b. When inspecting parts for excessive wear (C.3), assure there are no foreign particles embedded in the teflon seat. Inspect for nicks. Inspect the backup ring (20) and quad ring (19) on piston post.

- c. Remove the body cap o-ring (13) and clean contacting surface of body.
2. To check for seat leakage, follow same steps as listed under Pressure Piston/O-ring Inspection/Replacement, except for the following guidelines:
  - a. Pour a small amount of water in on top of the piston (through pressure piston bore in body). Crack open inlet pressure (50 psig maximum) to body and visually check for leakage by the cylinder gasket (18), TFE seat (15), or the body quad ring (19). After inspection, assure that water is removed before completing assembly and installing in line.

**NOTE:** *When piston (15) assemblies are used with comp seats, Cashco, Inc. does not recommend attempting to remove the comp seat. If composition seat is damaged, replace entire piston assembly.*

## SECTION VII

### VII. TROUBLE SHOOTING GUIDE

1. Erratic operation.

Possible Causes	Remedies
A. Oversized regulator; inadequate rangeability.	A1. Check actual flow conditions, re-size regulator for minimum and maximum flow. A2. Increase flow rate. A3. Decrease regulator pressure drop; decrease inlet pressure by placing a throttling orifice in inlet piping union. A4. Install next step higher range spring. A5. Before replacing regulator contact factory
B. Worn piston/cylinder; inadequate guiding.	B. Replace trim.
C. Weakened/broken piston spring.	C. Replace piston spring.

2. Sluggish operation.

Possible Causes	Remedies
A. Plugged piston balance port.	A. Remove trim and clean balance port.
B. Fluid too viscous.	B. Heat fluid. Contact factory.

### 3. Downstream Pressure will not reach desired setting

Possible Causes	Remedies
A. Regulator undersized.	A1. Confirm by opening bypass valve together with regulator. A2. Check actual flow conditions, re-size regulator; if regulator has inadequate capacity, replace with larger unit.
B. Plugged trim.	B. Remove trim and check for plugged holes in cylinder.
C. Incorrect range spring (screwing in CW of adjusting screw does not allow bringing pressure level up to proper level).	C. Replace range spring with proper higher range. Contact factory.
D. Too much droop.	D1. Review droop expected. D2. Contact factory.
E. Restricted pressure piston movement.	E. Assure no moisture in spring chamber at temperatures below freeze point. Assure no dust or debris entering vent openings.

### 4. Leakage through the spring chamber vents.

Possible Causes	Remedies
A. Failure of body quad ring and body backup ring.	A. Inspect the pressure piston, body quad ring and body backup ring. If scratched, nicked, or deformed - replace.

### 5. Excessive pressure downstream.

Possible Causes	Remedies
A. Regulator not closing tightly.	A.1. Inspect the seating. Clean and lap metal seat surfaces; replace if lapping does not remedy. If composition seats are depressed, nicked or embedded with debris, replace trim. A2. Inspect guides in body cap (Balanced trim). If damaged, replace body cap and/or piston, quad ring and back up ring.
B. Downstream block.	B. Check system; isolate (block) flow at regulator inlet - not outlet. Relocate regulator if necessary.
C. No pressure relief protection.	C. Install safety relief valve, or rupture disc.
D. Restricted pressure piston movement.	D. Assure no moisture in spring chamber at temperatures below freeze point Assure no dust or debris entering vent openings.

### 6. Excessive seat leakage.

Possible Causes	Remedies
A. Foreign matter on seating surface, erosion of seating surface, scratched body cap.	A. Inspect and replace damaged parts.
B. Balanced trim	B. Inspect piston quad ring and back up ring. Replace if damaged.

## SECTION VIII

### VIII. ORDERING INFORMATION

#### NEW REPLACEMENT UNIT vs PARTS "KIT" FOR FIELD REPAIR

To obtain a quotation or place an order, please retrieve the Serial Number and Product Code that was stamped on the metal name plate and attached to the unit. This information can also be found on the Bill of Material ("BOM"), a parts list that was provided when unit was originally shipped. (Serial Number typically 6 digits). Product Code typical format as follows: (last digit is alpha character that reflects revision level for the product).

□□□□ - □□□□ 7 - □□□□□□□□□□

#### **NEW REPLACEMENT UNIT:**

Contact your local Cashco, Inc., Sales Representative with the Serial Number and Product code. With this information they can provide a quotation for a new unit including a complete description, price and availability.



#### **CAUTION**

**Do not attempt to alter the original construction of any unit without assistance and approval from the factory. All purposed changes will require a new name plate with appropriate ratings and new product code to accommodate the recommended part(s) changes.**

#### **PARTS "KIT" for FIELD REPAIR:**

Contact your local Cashco, Inc., Sales Representative with the Serial Number and Product code. Identify the parts and the quantity required to repair the unit from the "BOM" sheet that was provided when unit was originally shipped.

**NOTE:** *Those part numbers that have a quantity indicated under "Spare Parts" in column "A" reflect minimum parts required for inspection and rebuild, - "Soft Goods Kit". Those in column "B" include minimum trim replacement parts needed plus those "Soft Goods" parts from column "A".*

If the "BOM" is not available, refer to the cross-sectional drawings included in this manual for part identification and selection.

A Local Sales Representative will provide quotation for appropriate Kit Number, Price and Availability.

The contents of this publication are presented for informational purposes only, and while every effort has been made to ensure their accuracy, they are not to be construed as warranties or guarantees, express or implied, regarding the products or services described herein or their use or applicability. We reserve the right to modify or improve the designs or specifications of such product at any time without notice. Cashco, Inc. does not assume responsibility for the selection, use or maintenance of any product. Responsibility for proper selection, use and maintenance of any Cashco, Inc. product remains solely with the purchaser.

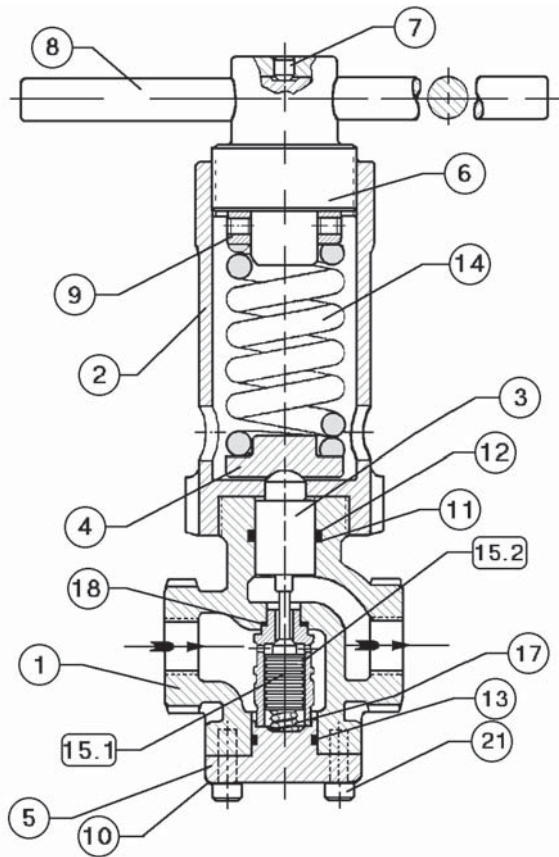

Figure 1: Basic Model 345 with metal seat design.

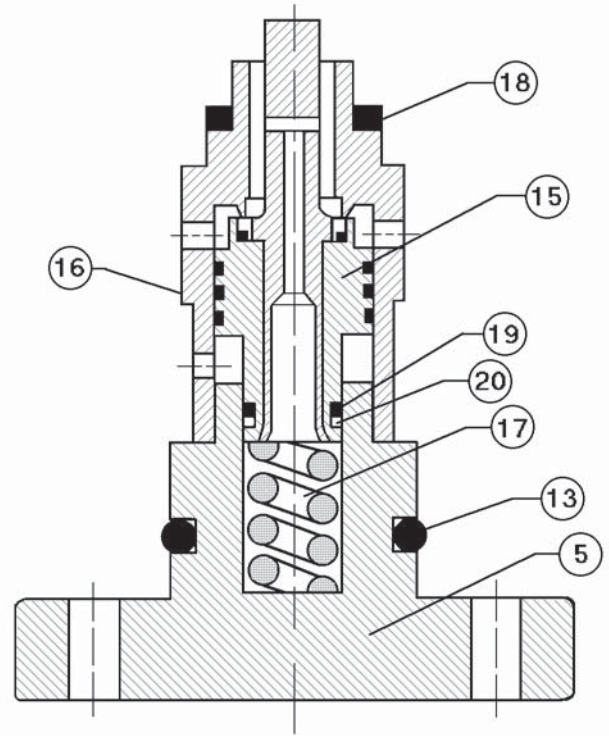

Figure 2: Composition Seat Design

Item No.	Description	Item No.	Description
1	Body	13	Body Cap O-Ring ‡
2	Spring Chamber	14	Range Spring
3	Pressure Piston	15	Piston - Comp
4	Spring Button	15.1	Piston-Metal ‡
5	Body Cap	15.2	Cylinder-Metal ‡
6	Adjusting Screw	16	Cylinder-Comp
7	Set Screw	17	Piston Spring ‡
8	T-Bar Handle	18	Cylinder Gasket ‡
9	Thrust Bearing	19	Piston Quad Ring
10	Name Plate	20	Piston Backup Ring
11	Body Quad Ring ‡	21	Socket Head Cap Screw (6)
12	Body Backup Ring ‡		

‡ Available with Parts Kit B

## ATEX 94/9/EC: Explosive Atmospheres and Cashco Inc. Regulators



These valves satisfy the safety conditions according to EN 13463-1 and EN 13463-5 for equipment group IIG 2 c.

Caution: Because the actual maximum temperature depends not on the equipment itself, but upon the fluid temperature, a single temperature class or temperature cannot be marked by the manufacturer.

Specific Precaution to Installer: Electrical grounding of valve must occur to minimize risk of effective electrical discharges.

Specific Precaution to Installer: Atmosphere vent holes should be plugged to further minimize the risk of explosion.

Specific Precaution to Maintenance: The Valve Body/ Housing must be regularly cleaned to prevent buildup of dust deposits.

Specific Precaution to Maintenance: Conduct periodic Continuity Check between Valve Body/ Housing and Tank to minimize risk of electrical discharges.

Attention: When repairing or altering explosion-protected equipment, national regulations must be adhered to. For maintenance and repairs involving parts, use only manufacturer's original parts.

ATEX requires that all components and equipment be evaluated. Cashco pressure regulators are considered components. Based on the ATEX Directive, Cashco considers the location where the pressure regulators are installed to be classified Equipment-group II, Category 3 because flammable gases would only be present for a short period of time in the event of a leak. It is possible that the location could be classified Equipment-group II, Category 2 if a leak is likely to occur. Please note that the system owner, not Cashco, is responsible for determining the classification of a particular installation.

### Product Assessment

Cashco performed a conformity assessment and risk analysis of its pressure regulator and control valve models and their common options, with respect to the Essential Health and Safety Requirements in Annex II of the ATEX directive. The details of the assessment in terms of the individual Essential Health and Safety Requirements, are listed in Table 1. Table 2 lists all of the models and options that were evaluated and along with their evaluation.

Models and options not listed in Table 2 should be assumed to not have been evaluated and therefore should not be selected for use in a potentially explosive environment until they have been evaluated.

Standard default options for each listed model were evaluated even if they were not explicitly listed as a separate option in the table. Not all options listed in the tables are available to all models listed in the tables. Individual TB's must be referenced for actual options.

When specifying a regulator that is to be used in a potentially explosive environment one must review the evaluations in Table 1 and 2 for the specific model and each and every option that is being specified, in order to determine the complete assessment for the unit.

A summary of the models and options found to have an impact on ATEX assessment due to potential ignition sources or other concerns from the ATEX Essential Health and Safety Requirements, are listed below.

1. The plastic knob used as standard on some models, (P1, P2, P3, P4, P5, P7, 3381, 4381, 1171, and 2171) is a potential ignition source due to static electricity. To demonstrate otherwise, the knob must be tested to determine if a transferred charge is below the acceptable values in IEC 60079-0 Section 26.14 (See items 25, 27, and 28 in Appendix A). Until the plastic knob has been shown to be acceptable, then either the metal knob option, or a preset outlet pressure option is required to eliminate this ignition source (See items 45 and 64 in Tables).
2. The pressure gauges offered as options on a few of the regulator models (DA's, P1-7, D, 764, 521), use a plastic polycarbonate window that is a potential ignition source due to static electricity. To demonstrate that the gauges are not a potential source of ignition, the gauges would need to be tested to determine if a transferred charge is below



indicating the gauge is compliant with the ATEX Directive (See items 26, 27, and 28 in Appendix A). Until compliance is determined, regulators should not be ordered with pressure gauges for use in potentially explosive environments.

3. Tied diaphragm regulators with outlet ranges greater than 100 psig should be preset to minimize the risk that improper operation might lead to an outboard leak and a potentially explosive atmosphere (See item 6 in Table 1).
4. Regulators must be ordered with the non-relieving option (instead of the self-relieving option) if the process gas they are to be used with is hazardous (flammable, toxic, etc.). The self-relieving option vents process gas through the regulator cap directly into the atmosphere while the non-relieving option does not. Using regulator with the self-relieving option in a flammable gas system could create an explosive atmosphere in the vicinity of the regulator.
5. Regulators with customer supplied parts are to be assumed to not have been evaluated with regard to ATEX and thus are not to be used in a potentially explosive environment unless a documented evaluation for the specific customer supplied parts in question has been made. Refer to Table 1 for all models and options that have been evaluated.

## Product Usage

A summary of ATEX related usage issues that were found in the assessment are listed below.

1. Pressure regulators and control valves must be grounded (earthed) to prevent static charge build-up due to the flowing media. The regulator can be grounded through any mounting holes on the body with metal to metal contact or the system piping can be grounded and electrical continuity verified through the body metal seal connections. Grounding of the regulator should follow the same requirements for the piping system. Also see item 30 in Table 1.
2. The system designer and users must take precautions to prevent rapid system pressurization which may raise surface temperatures of system components and tubing due to adiabatic compression of the system gas.
3. Heating systems installed by the user could possibly increase the surface temperature and must be evaluated by the user for compliance with the ATEX Directive. User installation of heating systems applied to the regulator body or system piping that affects the surface temperature of the pressure regulator is outside the scope of this declaration and is the responsibility of the user.
4. The Joule-Thomson effect may cause process gases to rise in temperature as they expand going through a regulator. This could raise the external surface temperature of the regulator body and downstream piping creating a potential source of ignition. Whether the Joule-Thomson effect leads to heating or cooling of the process gas depends on the process gas and the inlet and outlet pressures. The system designer is responsible for determining whether the process gas temperature may rise under any operating conditions. If a process gas temperature rise is possible under operating conditions, then the system designer must investigate whether the regulator body and downstream piping may increase in temperature enough to create a potential source of ignition.

The process gas expansion is typically modeled as a constant enthalpy throttling process for determining the temperature change. A Mollier diagram (Pressure – Enthalpy diagram with constant temperature, density, & entropy contours) or a Temperature – Entropy diagram with constant enthalpy lines, for the process gas, can be used to determine the temperature change. Helium and hydrogen are two gases that typically increase in temperature when expanding across a regulator. Other gases may increase in temperature at sufficiently high pressures.

## Product Declaration

If the above issues are addressed by selecting options that do not have potential sources of ignition, avoiding options that have not been assessed, and by taking the proper usage issue precautions, then Cashco regulators can be considered to be a mechanical device that does not have its own source of ignition and thus falls outside the scope of the ATEX directive.

Cashco, Inc.  
P.O. Box 6  
Ellsworth, KS 67439-0006  
PH (785) 472-4461  
Fax. # (785) 472-3539  
www.cashco.com  
email: sales@cashco.com  
Printed in U.S.A. IOM-345

Cashco GmbH  
Handwerkerstrasse 15  
15366 Hoppegarten, Germany  
PH +49 3342 30968 0  
Fax. No. +49 3342 30968 29  
www.cashco.com  
email: germany@cashco.com

Cashco do Brasil, Ltda.  
Al.Venus, 340  
Indaiatuba - Sao Paulo, Brazil  
PH +55 11 99677 7177  
Fax. No.  
www.cashco.com  
email: brazil@cashco.com