



Ranger QCT –
with Siemens Positioner

APPLICATIONS

The Ranger is a universal control valve that is applicable in most control valve applications, especially steam. It provides longer life on difficult services where conventional ball or globe control valves have problems with body or trim wear. It provides noise control for gaseous service, and cavitation and flashing control for liquid service. It is able to withstand temporary distortions due to “thermal shock” without compromising continued control of the process.

RANGER QCT

ECCENTRIC PLUG ROTARY CONTROL VALVE (ROTARY GLOBE)

The Ranger QCT is a control valve with a pneumatic spring-diaphragm actuator. It can be supplied with either a flanged or flangeless body style.

This rotary design provides excellent service life in a wide range of applications. Its most unique design feature centers around its Quick Change Trim – QCT. This concept provides front access to the valve body, allowing use of various lo-noise inserts, abrasion sleeve or alternate front-end seal retainers. Also, combinations of these features can be utilized to meet specific application needs.

The Ranger is the most user friendly control valve in the marketplace when it comes to maintenance. It takes a mere five minutes to change trim when out of the pipeline and requires no recalibration.

FEATURES

The Ranger has many important features that provide users with a cost-effective control valve:

- 1" – 8" (DN25 – 200)
- ANSI 150/300/600# pressure class capability with **flangeless** body-style
- ANSI 150/300/600# pressure class capability for **flanged** body-style in 1"-3" sizes; 150/300# for 4"-8" sizes
- Four body materials
- Ten trim combinations
- Dual seal rings - soft (Class VI) and metal (Class IV)
- Standard live-loaded packing
- Ease of maintenance
- Multiple reduced port configurations
- Cavitation trim
- Lo-noise trim
- Abrasion sleeve
- High capacity
- Multi-spring actuator.

BODY SUB-ASSEMBLY SPECIFICATIONS

Body Sizes: 1", 1-1/2", 2", 3", 4", 6" and 8".
(DN25, 40, 50, 80, 100, 150, 200.)

Trim: See Table A below for trim materials determined by body materials or option number.
See Tables 3 and 3A for trim designation numbers and material specifications.

Body Materials Pressure/ Temperature Ratings: DI – ASTM A395.
CS – ASTM A216, Gr. WCB.
SST – ASTM A351, Gr. CF8M.
HC – ASTM A494, Gr. CW-12MW
See Table 1A - 1D for material specifications.

TABLE A – PARTIAL TRIM MATERIALS							
Body Size	Option	Body	Port	Seal Retainer	Cage	Plug Bearings	
1", 1-1/2", 2", 3" (DN25, 40, 50, 80)	None	DI, CS	All	316 SST	Cast 316 SST	Nitronic 60	
		SST	All	316 SST			
		HC	All	HC			HC
4" (DN100)		DI, CS	Full	CS	Cast 410 SST	Nitronic 60	
		DI, CS	Reduced, AC, LN	316 SST	Cast 410 SST		
		SST	All	316 SST	Cast 316 SST		
6" & 8" (DN150, 200)		HC	All	HC	HC	Ultimet	
		DI *, CS	Full	CS	Cast 316 SST	Nitronic 60	
		DI *, CS	Reduced, AC, LN	316 SST			
		SST	All	316 SST			
1", 1-1/2", 2", 3" (DN25, 40, 50, 80)		Opt-40	HC	All	HC	HC	Ultimet
			CS, SST	All	316 SST	Cast 316 SST	Nitronic 60
	CS		Full	CS			
Reduced, AC, LN			316 SST				
4", 6", 8" (DN100, 150, 200)	SST		All	316 SST			

* 8" HF Ductile Iron Material is Not Available.

Eccentric Plug: Base material as indicated in Table 3 and footnote.

Stem

Sub-Assembly: Work-hardened 316 SST pin joining "groove" end to stem for 17-4PH stem; Nitronic 50HS for Nitronic stem; Alloy-25 for Alloy-25 stem.

Retainer Sleeve Sub-Assembly: As indicated in Table 3; insert material is non-removeable.

Retainer Screw: 316 SST or Monel

Yoke: 1", 1-1/2", 2", 8" HF – CS rectangular steel tubing.
3", 4", 6", 8" LF – Ductile iron.

Option - ISO 5211 Actuator Mount.

Yoke Bolting: 18-8 SST studs, cap screws and nuts.

Packing Assembly: Common Parts for "Live-Loading":
Retainer & Spacer – 316 SST
Belleville Spring Washers – SST
Packing Follower – 18-8 SST
Packing Flange – 18-8 SST
Studs, Nuts & Washers – 18-8 SST
Follower Bushing Bearing – TFE.
Standard: TFE V-rings and adapters; non-split.

Optional: Flexible graphite die-formed into lower density, interlocking rings, with higher density adapter rings, and top/bottom braided graphite filament rings.

Soft Seal Ring: TFE: Glass-filled or Carbon-filled.

All Inserts: 316 SST or Hastelloy-C

Seal Retainer Screws: 18-8 SST or Hastelloy C cap screw.

Flange Surface Finish: 250/125 micro-inch R_a (equivalent to 250/125 AARH). Suitable for use with spiral-wound metallic gaskets.

Clamping Companion Flanges: Not supplied with valve unit. Use only steel, stainless steel or Hastelloy-C piping flanges; socket weld, slip-on, or weld-neck types; RF or FF.
Per ANSI B16.5 Dimensions: All sizes of CS, SST, HC or DI body material; 150# or 300# flange pressure class. All sizes of CS, SST or HC body material; 600# flange pressure class except 6".
Per DIN Dimensions: May be installed between PN40 flanges in sizes DN25 - DN50.

Body Face-to-Face Dimensions: Per ISA–75.08.02 for flangeless control valves. See Figure 11, dimension “E”. Integral flanged units meet the same dimensions.

Minimum Body Pressure: Standard Construction:
P = Ambient ≈ 0 psig (0 Barg).
Opt -38V Packing @ Vacuum:
P = Full Vacuum = 0 psia (0 Bara).

Flow Direction: Standard & Reverse flows.

Field reversible sizes 1" through 4" (DN25–100); sizes 6" & 8" (DN150 & 200) require replacement of metal seal ring.

Seal Retainer		Flow Direction
Full or Reduced Port		Both
Anti-Cav - AC		Reverse Flow
Lo-Noise	LNA, LNB	Both

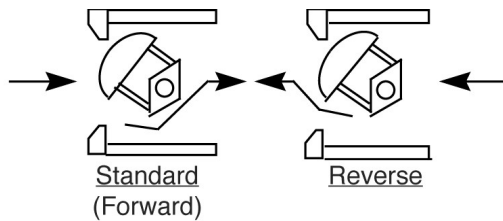

Seat Design: Standard – Standard flow direction.
Dual seal rings; composition soft seal with metallic backup seal. Inlet pressure assists sealing.

Optional – Reverse flow direction.
Inlet pressure does not assist sealing. Reverse flow may increase seat leakage.

Seat Leakage: Per ANSI/FCI 70-2 @ $\Delta P_{min} \geq 50$ psi (3.45 Bar).

Rangeability: Function of seal retainer and lo-noise trim.

Seal Retainer	Seal Ret. Only	Seal Ret. + LN Insert
Full Port	125:1	80:1
0.6 Reduced Port	75:1	50:1
0.4 Reduced Port	50:1	35:1
0.2 Reduced Port	25:1	15:1
Anti-Cav - AC1,AC2	20:1	N/A
Lo-Noise - LNA,LNC	80:1	30:1
Lo-Noise - LNB,LND	60:1	25:1

Plug Travel: 1" thru 8" LF – 0°-to-90° rotation.
8" HF 0°-to-95° rotation.

Plug & Stem Torque Limits:

Designed Max Torque (Ft/lbs) for Plug to Stem Connection				
Current Trims	ST1, ST2, ST7	ST6, ST8, CT1, CT2	HT1, HT2, HT7	
Plug Material	17-4 PH SST	Stellite #6	Monel	
SIZE	1"	45	35	25
	1.5"	55	45	30
	2"	55	45	30
	3"	255	195	140
	4"	440	340	240
	6"	600	460	329
	8" LF	600	460	329
	8" HF	1485	1150	810

Cv Capacity: Function of seal retainer and internal lo-noise trim. See Tables 6 through 9.

Body Size		Max Cv	Max Kv
inch	(DN)		
1"	(25)	14	12
1-1/2"	(30)	25	21
2"	(50)	71	61
3"	(80)	170	146
4"	(100)	325	280
6"	(150)	710	612
8" LF	(200)	710	612
8" HF	(200)	1260	1086

NOTE: Kv = Cv/1.16; Kv is metric flow coefficient.

Stem Packing: Standard: Patented “live-loaded” V-ring packing using Belleville spring washers (see Fig.1); body with integral extended bonnet. Temperature Range $-325^{\circ} \leq T \leq 750^{\circ}F$ ($-198^{\circ} \leq T \leq 400^{\circ}C$), with exposed, uninsulated bonnet above $400^{\circ}F$ ($205^{\circ}C$).

Opt-38 HT: For high temperature service; live-loaded, solid ring packing. Temperature range $-20^{\circ} \leq T \leq 750^{\circ}F$ ($-29^{\circ} \leq T \leq 400^{\circ}C$), with insulated bonnet.

Opt-38V: For continuous vacuum service; same as standard, except V-rings are inverted.

Gasket: Standard–316L SST formed chevron cross section, spirally wound type, flexible graphite filled.

Painting: Standard–All non corrosion resistant portions to be painted with corrosion resistant epoxy paint per Cashco Spec #S-1606.

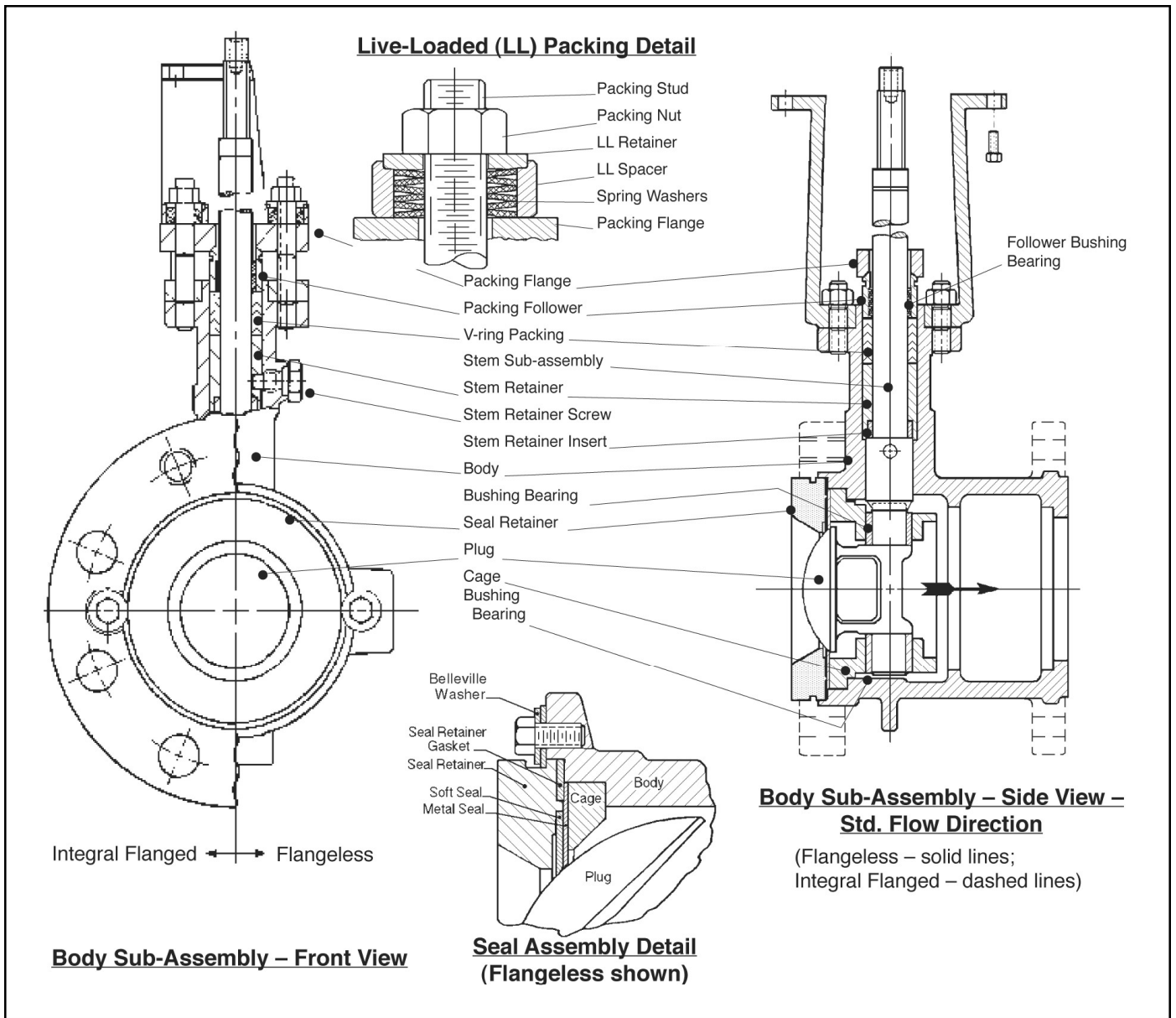

FIGURE 1:
Ranger Body Sub-Assembly Cutaways

1" - 8" LF ACTUATOR TECHNICAL SPECIFICATIONS

Basic Design: 0–90° Rotary. Spring-diaphragm type. Rolling diaphragm with multiple springs. Enclosed linkage. Field-reversible for “direct” or “reverse” action (see Figure 2). Standard with manual handwheel operator.

Action	Model No.	Body Size		Bench Setting Range	
		in	(DN)	psig	(Barg)
Direct: ATC-FO (Increase in air “LOAD” rotates valve stem CW, closing valve)	48D-01	1", 1-1/2", 2"	(25, 40, 50)	5–15	(0.34–1.03)
	148D-01	3"	(80)	5–13	(0.34–0.90)
	148D-02	4", 6", 8"	(100, 150, 200)	10–26	(0.69 – 1.79)
Reverse: ATO-FC (Increase in air “LOAD” rotates valve stem CCW, opening valve)	48R-01	1", 1-1/2", 2"	(25, 40, 50)	5–15	(0.34–1.03)
	148R-01	3"	(80)	5–13	(0.34–0.90)
	148R-02	4", 6", 8"	(100, 150, 200)	10–26	(0.69 – 1.79)

ATC-FO = Air-to-Close, Fail Open;
ATO-FC = Air-to-Open, Fail Close.
NOTE: For special 5 - 13 psig bench set range for 4" size ONLY, contact the factory for special product code.

Size, Stroke & Volume:

Basic Model No.	Nominal Diaphragm Area in ² (cm ²)	Lever Arm Length in (mm)	Nominal Stroke * in (mm)	Volumes	
				Clearance in ³ (cm ³)	Volumetric in ³ (cm ³)
48D 48R	48in ² (310)	1.375 (34.9)	1.94 (49.3)	27in ³ (440)	87in ³ (1425)
148D 148R	148in ² (955)	1.875 (47.6)	2.65 (67.3)	90in ³ (1475)	372in ³ (6095)

* To generate 90° rotation.

Maximum Operating Supply Pressure:
48 D/R = 20 psig (1.38 Barg).
148 D/R = 36 psig (2.48 Barg).

Ambient Temperature Range:
-20° ≤ T_{amb} ≤ 180°F.
(-29° ≤ T_{amb} ≤ 83°C).

Air Connection: 1/4" female NPT.

Travel Stop Screw: Standard – Limits travel to 0°–90° rotational travel.

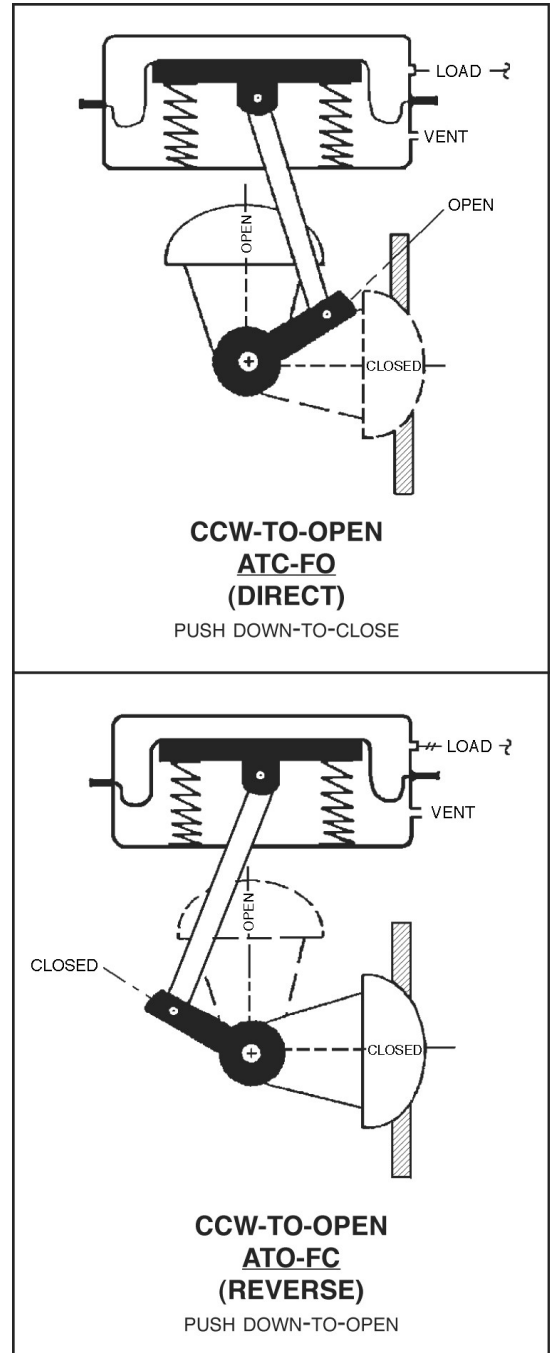

Figure 2:
Plug vs. Lever Arm vs. Actuator Orientation

1" - 8" LF ACTUATOR SUB-ASSEMBLY MATERIAL SPECIFICATIONS

Casting & Diaphragm Plate:	Cast aluminum; ASTM B108, Alloy 319.
Springs:	Epoxy coated steel.
Diaphragm:	Rolling-type; Buna-N with polyester fabric.
Handwheel:	Cast aluminum.
Arm Housing:	Cast iron.
Handwheel Stem:	316 SST.
Handwheel Gland:	Naval brass.
Locking Lever:	Plated malleable iron.
Threadseal:	18-8 SST with Buna-N insert.
Flange Bolting:	18-8 SST.
Turnbuckle Assembly:	Plated steel and SST.
Travel Stop Screw & Jam nut:	Plated steel.
Lever Arms:	SST with SST bolt and nut.
Cam/Spacer:	SST.
Nameplate:	SST.

Position Indicator Assembly with 73 P/P Positioner:	<p>Plate – SST with high visibility red indicating zone displaying degree of valve “opening”.</p> <p>Housing – 48D/R – aluminum; 148D/R – cast iron.</p> <p>Lens – plastic.</p> <p>Coverplate – SST.</p> <p>External screws – SST.</p> <p>Outboard stem bearing – steel ball bearing.</p> <p>NOTE: With D3 and PS2 the position indicator is integral with positioner, and housing is cast iron.</p>
--	---

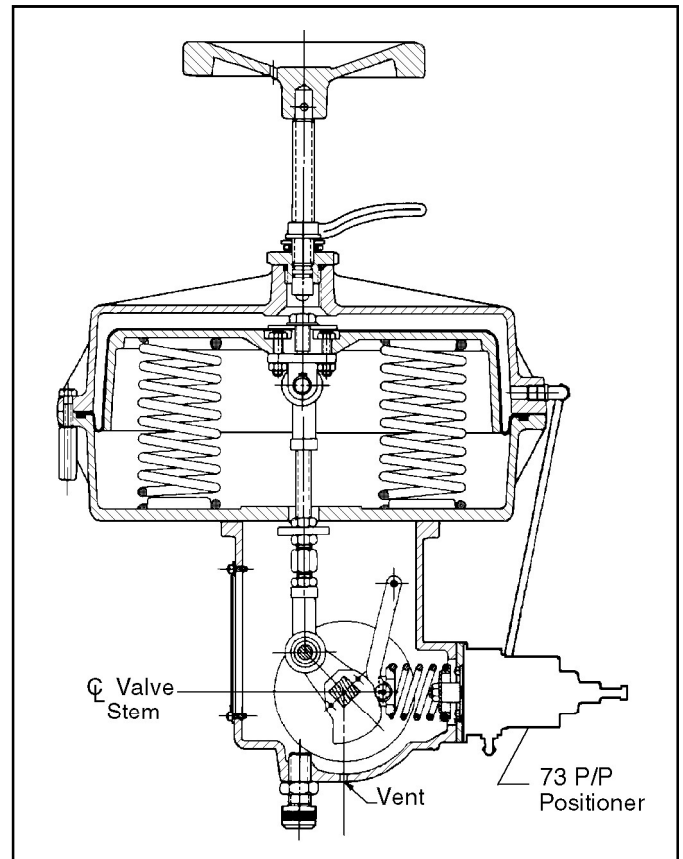

Figure 3: Model 148R Actuator with 73 P/P Positioner with Manual Handwheel Operator

8" HF ACTUATOR TECHNICAL SPECIFICATIONS

Basic Design:	0–95° Rotary. Scotch Yoke Actuator Field-reversible for “direct” or “reverse” action.
Bench Range:	0-60 PSIG (0-4.14 Barg)
Maximum Operating Supply Pressure:	116 psig (8 Barg).
Ambient Temperature Range:	$-20^{\circ} \leq T_{amb} \leq 170^{\circ}\text{F}$. ($-29^{\circ} \leq T_{amb} \leq 76^{\circ}\text{C}$).
Air Connection:	1/4" female NPT.

8" HF ACTUATOR SUB-ASSEMBLY MATERIAL SPECIFICATIONS

Casting & Diaphragm Plate:	Extruded Aluminum
Springs:	SST
Piston:	Cast Aluminum
Seals	Buna-N
Cam/Spacer:	316 SST
Nameplate:	SST

OPTION SPECIFICATIONS

Option-3:	<p><u>NO MANUAL HANDWHEEL OPERATOR.</u> A handwheel and locking lever is supplied as standard for the Ranger except the 8" HF units. <u>This option covers supplying the unit with NO handwheel operator.</u></p> <p><u>Reverse Action; ATO-FC:</u> Actuator provided with adjusting screw assembly to assist for internal trim removal (see Figure 4).</p> <p>NOTE: Requires that actuator be pressurized to stroke the plug to near “closed” position, properly orienting tongue and groove connection to allow disengagement for trim removal.</p>
------------------	--

Option-7:	<p><u>LINE BOLTING.</u> For flangeless units only. See Figure 12 for required dimensions and installation clearances.</p> <p><u>Opt-7A:</u> Heat treated, alloy steel studs per ASTM A193, Gr. B7; carbon steel nuts per ASTM A194, Gr. 2H. Temperature Range: $-20^{\circ} \leq T \leq 750^{\circ}\text{F}$ ($-29^{\circ} \leq T \leq 400^{\circ}\text{C}$).</p> <p><u>Opt-7C:</u> Full cryogenic, corrosion resistant, 18-8 SST (316 SST) strain-hardened studs per ASTM A193, Gr. B8M; 18-8 SST nuts per ASTM A194, GR. 8M. Temperature Range: $-325^{\circ} \leq T \leq 750^{\circ}\text{F}$ ($-198^{\circ} \leq T \leq 400^{\circ}\text{C}$).</p>
------------------	--

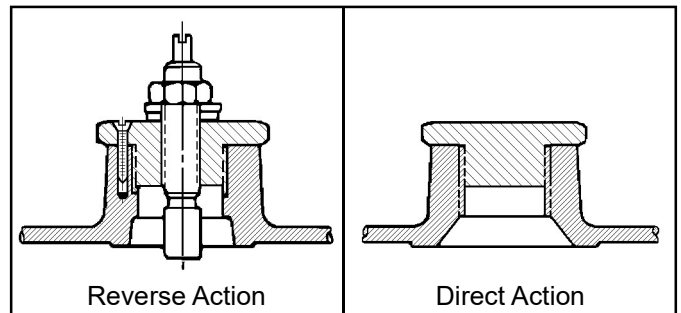

Figure 4:
Option-3: No Manual Handwheel Operator - Casing Closure

Option-18: SLURRY TRIM. Includes a drilled and tapped (1/8" female NPT, with pipe plug) stem retainer screw to allow purge of neck (bonnet) area of valve body. Fluorocarbon elastomer O-ring impedes ingress of flowing solids into neck zone. Used primarily with saturated solutions that form hard, crusty buildup upon cooling, eventually causing stem "binding". Includes abrasion sleeve with body sizes 1-1/2" – 8". ST8 Trim only. ST8 Trim. Reverse Flow direction only. See Figure 5. Temperature Range: -20°F ≤ T ≤ 400°F (-29° ≤ T ≤ 205°C).

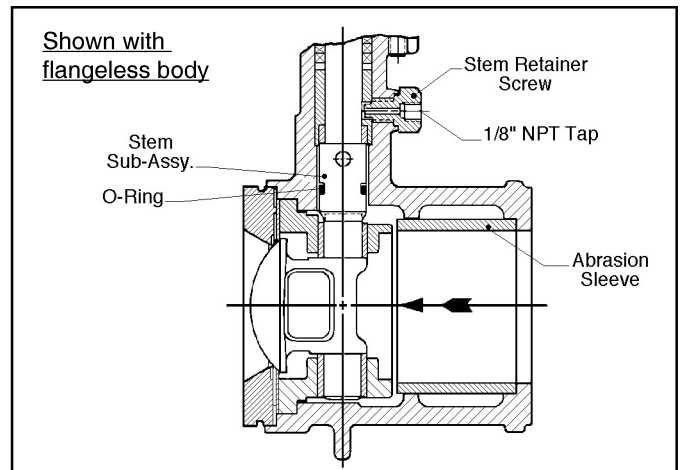

Figure 5: Option-18, Slurry Trim

Option-38HT: HI-TEMP PACKING. Standard TFE V-ring packing is replaced with live-loaded flexible graphite ribbon deformed into interlocking rings with high density graphite adapters and top/bottom braided graphite filament rings. Primarily recommended for higher temperature service. Use of this optional packing REQUIRES USE OF A VALVE POSITIONER.

Option-56: SPECIAL CLEANING. Applicable for all body materials. Cleaning per Cashco Spec. #S-1542. Not suitable for oxygen service.

Option-38V: VACUUM PACKING. Same as standard V-ring packing, except V-rings are inverted (with respect to standard) to seal against air ingress. Orient valve "outlet" to be exposed to the highest vacuum level.

Option-40: NACE SERVICE: Apply only with CS or SST body materials. For sour gas or liquid applications. Specify only trim designation nos. CT1 & CT2. Meets National Association of Corrosion Engineering (NACE) materials standard #MR0175, for exposure of valve internals to fluids with sour gas (H₂S) present. Requires use of CF8M (cast 316 SST) cage and Nitronic 60 bearings in CS body sizes 4", 6" and 8" (DN100, 150, 200). Temperature range: -20° ≤ T ≤ 400°F (-29° ≤ T ≤ 205°C°).

Option-55: SPECIAL CLEANING. Cleaning per Cashco Spec. #S-1134. Only applicable for SST body material. Acceptable cleaning level for oxygen gas service. Use for non-cryogenic, oxygen service.

“QCT” – RELATED TRIM VARIATIONS

Anti-Cavitation Trim:

Anti-cavitation (AC) trim eliminates or reduces the level of cavitation present in clean liquid service. It locates any cavitation to a point where the valve body and internal trim are spared any damage effects. (Also effective in flashing services.) See Figure 6.

Only metal seated trims are available with the AC seal retainers.

The AC seal retainer design concept utilizes a network of 2-stage orifices to accomplish the following:

- Generate smaller vapor bubbles
- Locate the bubbles near the seal retainer
- Hasten downstream bubble implosion
- Direct flow to downstream pipe center
- Reduce noise
- Reduce vibration
- Reduce downstream pipe wall damage.

The AC seal retainer requires reverse flow direction. Seat leakage is maintained to Class IV or better. See Table 2 for pressure drop limitations for AC trim. See Table 8 for flow coefficients.

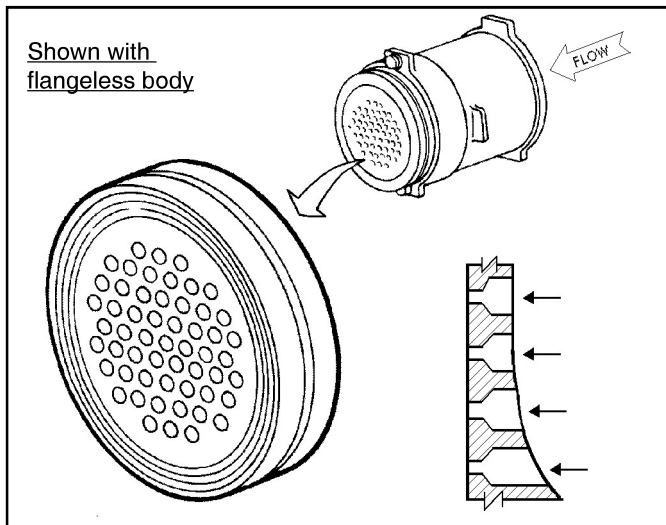

Figure 6:
Anti-Cavitation - AC Trim

Reduced Orifice Trim:

Three sizes of Reduced Orifice Trims are available for the Ranger QCT 1" - 8" LF units – 0.2, 0.4 and 0.6 Cv, and .3 and .5 for 8" HF units.

Reduced Orifice Trim is recommended to improve control loop resolution for control valve installations when a line sized valve is more economical than pipe reducers and smaller valves, or when future increases in capacity are planned. See Figure 7.

Reduced Orifice Trims utilize elongated openings to control the maximum Cv while maintaining the inherent flow characteristic of the standard trim.

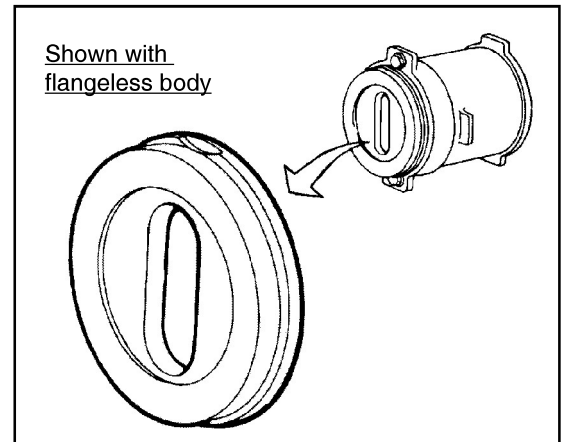

Figure 7:
Reduced Orifice Trim

Lo-Noise Trim – LNA/LNB:

LNA/LNB are similar to the AC1/AC2 seal retainer, except that a soft seal can be installed and the intent is for gas service up to 400°F (205°C) or steam service up to 366°F (186°C). The AC1/AC2 seal retainer is not available in soft seal trims. See Figure 8.

LNB is supplied with fewer orifices than LNA. See Table 6 for flow coefficients. Inherent character remains linear. Applies to all sizes.

For saturated steam at pressures above 435 psig (30 Barg); because the steam “flashes” upon pressure drop, ONLY AC2 should be applied.

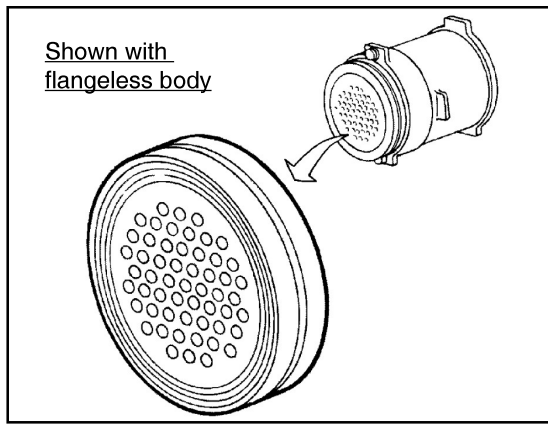

Figure 8:
Lo-Noise Trim – LNA/LNB

LNA and LNB are normally applied together with an LN2 through LN4 lo-noise insert; this combination can remove 12–20 dBA of noise.

Lo-Noise Trim - LN2 thru LN4: For gas or steam service only. Available for body sizes 1-1/2" – 8" (DN40 – 200) as an insert. Material is 316 SST.

LN2, LN3 and LN4 are similar except each varies in the number of orifices present. See Table 9 for flow coefficients.

LN2 is available for 1-1/2" – 8" (DN40 – 200) body sizes, and is normally applied together with an LNA or LNB seal retainer; this combination can remove 10–16 dBA of noise.

LN3 is available for sizes 3" – 8" LF (DN80 – 200), LN4 is available for sizes 4" – 8" LF (DN100 – 200). See Table 9 for flow coefficients.

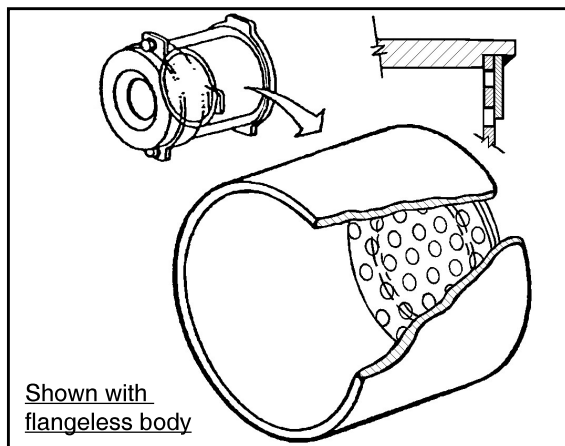

Figure 9:
Lo-Noise Trim – LN2 thru LN4

Abrasion Sleeve:

The abrasion sleeve (AS) prevents the impingement of solids on the back-end portion of the valve body wall. The standard cage protects the other most vulnerable portion of the valve body. Together these replaceable parts protect the Ranger body from the abrasive action of solids in the flowing fluid.

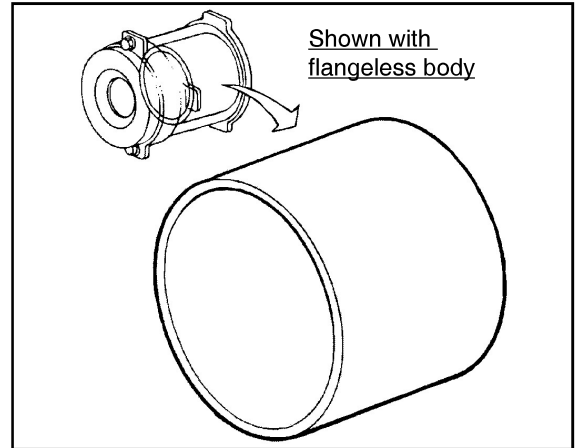

Figure 10:
Abrasion Sleeve

The abrasion sleeve is also recommended for cryogenic service where the body is exposed to sudden thermal shock; i.e. liquid slug.

Available in 316 SST for 1-1/2" – 8" (DN40 – 200) valves. Identified as Opt-AS. Figure 10.

TECHNICAL SPECIFICATIONS

TABLE 1A – MATERIAL PRESSURE vs. TEMPERATURE RATINGS DUCTILE IRON per ANSI B16.42						
Body Material		End Connection	English Units		Metric Units	
General	ASTM Spec. No.		Pressure (psig)	Temperature (°F)	Pressure (Barg)	Temperature (°C)
Cast Ductile Iron (DI)	A395		Flangeless, mates to 150# Flg. * (PN20)	250	-20 to +100	17.2
		235		200	16.2	94
		215		300	14.8	149
		200		400	13.8	205
		185		450	12.8	233
		170		500	11.8	260
		155		550	10.7	288
		140		600	9.7	316
		125		650	8.6	344
		640		-20 to +100	44.1	-29 to +38
		Flangeless, mates to 300# Flg. (PN50)	600	200	41.4	94
			565	300	39.0	149
			525	400	36.2	205
			510	450	35.2	233
			495	500	34.2	260
			480	550	33.1	288
			465	600	32.1	316
			450	650	31.0	344

* Based upon CS pipe material.

TABLE 1B – MATERIAL PRESSURE vs. TEMPERATURE RATINGS CARBON STEEL PER ANSI B16.34						
Body Material		End Connection	English Units		Metric Units	
General	ASTM Spec. No.		Pressure (psig)	Temperature (°F)	Pressure (Barg)	Temperature (°C)
Cast Carbon Steel	A216, GR. WCB		Flanged, Flangeless mates to 150# Flg. (PN20)	285	-20 to +100	19.7
		260		200	18.0	94
		230		300	15.9	149
		200		400	13.8	205
		185		450	12.8	233
		170		500	11.8	260
		155		550	10.7	288
		125		650	8.6	344
		110		700	7.6	372
		95		750	6.6	400
		Flanged, Flangeless mates to 300# Flg. (PN50)	740	-20 to +100	51.1	-29 to +38
			675	200	46.6	94
			655	300	45.2	149
			635	400	43.8	205
			615	450	42.4	233
			600	500	41.4	260
			575	550	39.7	288
			535	650	36.9	344
			535	700	36.9	372
			505	750	34.8	400
		Flanged, Flangeless mates to 600# Flg. (PN100) *	1480	-20 to +100	102.1	-29 to +38
			1350	200	93.1	94
			1315	300	90.7	149
			1270	400	87.6	205
			1235	450	85.2	233
			1200	500	82.8	260
			1145	550	79.0	288
			1075	650	74.2	344
			1010	750	69.7	400

* Not available for 4", 6" and 8" (DN 100, 150, 200) body sizes with integral flanges. Not available "flangeless" for the 8" (DN200) body size.

**TABLE 1C – MATERIAL PRESSURE vs. TEMPERATURE RATINGS
STAINLESS STEEL PER ANSI B16.34 ***

Body Material		End Connction	English Units		Metric Units	
General	ASTM Spec. No.		Pressure (psig)	Temperature (°F)	Pressure (Barg)	Temperature (°C)
Cast Stainless Steel	A351, Gr. CF8M	Flanged, Flangeless mates to 150# Flg. (PN20)	275 **	-325 to +100	19.0 **	-198 to +38
			235	200	16.2	94
			215	300	14.8	149
			195	400	13.5	205
			180	450	12.4	233
			170	500	11.8	260
			155	550	10.7	288
			125	650	8.6	344
			95	750	6.6	400
Cast Stainless Steel	A351, Gr. CF8M	Flanged, Flangeless mates to 300# Flg. (PN50)	720 **	-325 to +100	50.0 **	-198 to +38
			620	200	42.8	94
			560	300	38.7	149
			515	400	35.6	205
			495	450	34.1	233
			480	500	33.1	260
			465	550	32.1	288
			445	650	30.7	344
			430	700	30.0	372
			425	750	29.3	400
		Flanged, Flangeless mates to 600# Flg. (PN100) ***	1440	-325 to +100	99.3	-198 to +38
			1240	200	85.6	94
			1120	300	77.3	149
			1025	400	70.7	205
			990	450	68.3	233
			955	500	65.9	260
			925	550	63.8	288
			890	650	61.4	344
			870	700	60.0	372
			855	750	58.9	400

* Pressure Rating shall not exceed 375 psig (25.8 Barg) when body material is SST and process medium is oxygen. (CGA G-4.4 2012)

** P_{Max} for Cryogenic Opt-36 down to -325°F (-198°C).

*** Not available for 4", 6" and 8" (DN100, 150, 200) body sizes with integral flanges. Not available "flangeless" for the 8" (DN200) body size.

**TABLE 1D – MATERIAL PRESSURE vs. TEMPERATURE RATINGS
HASTELLOY-C PER ANSI B16.34**

Body Material		End Connection	English Units		Metric Units	
General	ASTM Spec. No.		Pressure (psig)	Temperature (°F)	Pressure (Barg)	Temperature (°C)
Cast Hastelloy-C	A494, Gr. CW-12MW	Flanged or Flangeless mates to 150# Flg. (PN20)	230	-325 to +100	15.9	-198 to +38
			210	200	14.6	94
			200	300	13.7	149
			190	400	12.9	205
			180	450	12.4	233
			170	500	11.7	260
			155	550	10.7	288
		125	650	8.6	344	
		95	750	6.5	400	
		Flanged or Flangeless mates to 300# Flg. (PN50)	600	-325 to +100	41.4	-198 to +38
			550	200	38.1	94
			520	300	35.9	149
			490	400	33.7	205
			475	450	32.8	233
			465	500	32.0	260
			450	550	31.0	288
		430	650	29.6	344	
		410	750	28.3	400	
		Flanged or Flangeless mates to 600# Flg. (PN100) *	1200	-325 to +100	82.7	-198 to +38
			1105	200	76.2	94
			1040	300	71.7	149
			980	400	67.6	205
			950	450	65.6	233
			925	500	63.9	260
			900	550	62.2	288
		860	650	59.1	344	
		820	750	56.5	400	

* Not available for 4", 6" and 8" (DN 100, 150, 200) body sizes with integral flanges. Not available "flangeless" for the 8" (DN200) body size.

TABLE 2 – MAXIMUM PRESSURE DROP CAPABILITY

Body		Bench Set Range psid (bard)	With Positioner ¹				Without Positioner ²			With I/P Transducer ³		
Mat'l.	Size		Trim				Trim			Trim		
			Std. psid (bard)	AC * psid (bard)	Std. psid (bard)	Chem ** psid (bard)	Std. psid (bard)	AC * psid (bard)	Chem ** psid (bard)	Std. psid (bard)	AC * psid (bard)	Chem ** psid (bard)
CS or SST	1" (DN25)	5-15 (0.34-1.03)	1400 (96.5)	600 (41.4)	600 (41.4)	700 (48.3)	600 (41.4)	600 (41.4)	600 (41.4)	600 (41.4)	400 (27.6)	400 (27.6)
	1-1/2" (DN40)	5-15 (0.34-1.03)	1200 (82.8)	600 (41.4)	600 (41.4)	600 (41.4)	600 (41.4)	600 (41.4)	600 (41.4)	600 (41.4)	400 (27.6)	400 (27.6)
	8" HF (DN 200)	0-60 (0.00-4.14)	350 (24.13)	350 (24.13)	350 (24.13)	350 (24.13)	N/A	N/A	N/A	N/A	N/A	N/A
DI, CS, SST or HC	2" (DN50)	5-15 (0.34-1.03)	600 (41.4)	600 (41.4)	600 (41.4)	300 (20.7)	400 (27.6)	400 (27.6)	300 (20.7)	300 (20.7)	300 (20.7)	200 (13.8)
	3" (DN80)	5-13 (0.34-0.90)	600 (41.4)	600 (41.4)	600 (41.4)	300 (20.7)	600 (41.4)	600 (41.4)	300 (20.7)	400 (27.6)	400 (27.6)	200 (13.8)
	4" (DN100)	10-26 (0.69-1.79)	600 (41.4)	600 (41.4)	300 (20.7)	200 (13.8)	300 (20.7)	300 (20.7)	150 (10.3)	X		
	6", 8" (DN150,200)	10-26 (0.69-1.79)	300 (20.7)	300 (20.7)	200 (13.8)	150 (10.3)	200 (13.8)	200 (13.8)	150 (10.3)			
DI or HC	1", 1-1/2" (DN25, 40)	5-15 (0.34-1.03)	600 (41.4)	600 (41.4)	600 (41.4)	600 (41.4)	600 (41.4)	600 (41.4)	600 (41.4)	400 (27.6)	400 (27.6)	400 (27.6)
FLOW DIRECTION			Std.	Rev.	Rev.	Std.	Both	Rev.	Both	Both	Rev.	Both

¹ Use the "With Positioner" Max ΔP values for use in ON-OFF service.
² 3-15 psig (0.21-1.03 Barg) or 10-26 (0.69-1.79) SIG directly to actuator.
³ 1-17 psig (0.07-1.17 Barg) OUTPUT LOAD directly to actuator (no positioner); 4-20mA INPUT SIG. Tight shutoff may NOT be attained.
 * "AC" = "anti-cavitation" seal retainer.
 With a 3-15 psig (0.21-1.03 Barg) SIG, requires a 1:2 air supply booster.

** "Chem Trim" is defined as any trim that uses a Stellite #6 plug or a Nitronic 50HS Stem; includes trim designation nos. CT1 & CT2.
NOTES:
 1. The above pressure drops apply to the valve as a "unit", including all seal retainers and lo-noise inserts.
 2. When "Chem Trim" is applied with an AC seal retainer, the lower of the two "maximum pressure drop" values is to be the upper limit.

TABLE 3 – TRIM MATERIALS vs DESIGNATION NOS.

Part Description	Trim Designation Nos.									
	ST1	ST2	ST6	ST7 **	ST8 ***	CT1	CT2	HT1	HT2	HT7
Plug *	Cast 17-4PH	Cast 17-4PH	Cast Stellite #6	Cast 17-4PH	Cast Stellite #6	Cast Stellite #6	Cast Stellite #6	Cast Monel	Cast Monel	Cast Monel
Stem	17-4PH	17-4PH	17-4PH	17-4PH	17-4PH	Nitronics 50HS	Nitronics 50HS	Alloy 25	Alloy 25	Alloy 25
Metal Seal Ring	Inconel X-750	Inconel X-750	Inconel X-750	Inconel X-750	Inconel X-750	Inconel 625	Inconel X-750	Inconel X-750	Inconel X-750	Inconel X-750
Soft Seal Ring	GF-TFE	None	None	TFE + C	None	GF-TFE	GF-TFE	GF-TFE	None	TFE + C
Stem Retainer	316 SST	316 SST	316 SST	316 SST	316 SST	316 SST	316 SST	HC	HC	HC
Stem Retainer Screw	316 SST	316 SST	316 SST	316 SST	316 SST	316 SST	316 SST	Monel	Monel	Monel
Retainer Insert - Non-Removable	Carbon	Carbon	Carbon	Carbon	Carbon	Carbon	Carbon	Carbon	Carbon	Carbon
Abrasion Sleeve	Opt.	Opt.	Opt.	Opt.	Included	Opt.	Opt.	Opt.	Opt.	Opt.
Stem O-ring	NA	NA	NA	NA	Included	NA	NA	NA	NA	NA
Temperature Range	A	B	C	D	C	E	E	E	B	D
Primary Service Function	General – Standard				Slurry Opt-18	NACE Opt-40		Corrosive – Chemical		
Seal Retainer Groupings	A, B	A, AC	A, AC	A, B	A	A, B	A, B	A, B	A, AC	A, B
Insert Groupings	1, 2	1, 2	1, 2	1, 2	2	1, 2	1, 2	1, 2	1, 2	1, 2

- * Cast 17-4PH Plugs are hard chrome plated; cast stellite and Monel plugs are electroless nickel coated.
- ** Class IV seat leakage guaranteed; approaches Class VI. Can not be factory tested to Class VI due to low ambient temperature at testing.
- *** For Reverse Flow installation.
- √ Consult factory for cryogenic applications that are noisy.

“C” = Carbon filled
 “GF” = Glass filled
 Opt. = Optional
 NA = Not Available

Hardness - Rc	
Chrome Plate	60–65
ENC - heat treated	66–69

KEY	Seal Retainer Grouping
A	Full, 0.6, 0.4, 0.2
B	LNA, LNB
AC	AC1, AC2

KEY	Inserts
1	LN2, LN3, LN4 *
2	Abrasion Sleeve *
* Not available for 1" body size.	

KEY	Temperature Range	
	°F	°C
A	-325 to +400	(-198 to +205)
B	-325 to +750	(-198 to +400)
C	-150 to +750	(-100 to +400)
D	-150 to +500	(-100 to +260)
E	-150 to +400	(-100 to +205)

TABLE 3A – MATERIAL SPECIFICATIONS

Description	Form	ASTM NO. (AMS No.)	UNS No.	Heat Treat- Misc.	Hardness Rockwell
316 SST	Wrought Bar	A479, Gr 316	S31600	Annealed	B88
Cast 316 SST	Cast	A351, Gr CF8M	J92900	Annealed	B85
Cast 410 SST	Cast	A217 CA15	J91150	Tempered	B98
Cast 17-4 PH	Cast	A747, Gr CB7-Cu-1	J92180	Cond. H1100	C35-38
17-4 PH	Wrought Bar	A564	S17400	Cond. H 1075	C35
Inconel X-750	Sheet	(AMS 5542)	N07750	Annealed	B88
Inconel 625	Sheet	B443, Gr 625	N06625	Annealed	B88
Nitronics 50	Wrought Bar	A479, Gr XM-19	S20910	Cond. HS	C35
Stellite #6B	Cast	(AMS 5387)	R30006	Heat Treated	C40-42
Nitronic 60	Wrought Bar	A276	S21800	SOL ANNEALED	C22-23
Hastelloy C	Cast	ASTM A494 Gr.CW-12-MW	N30002	Heat Treated	---
Monel	Cast	ASTM A494 Gr. M30H	N24030	None	---
Alloy-25	Wrought Bar	ASTM F90	R30605	Annealed	---
Hastelloy C	Wrought Bar	ASTM B574	N10276	None	---
Ultimet	Wrought Bar	ASTM B815	R31233	None	---

TABLE 4 – APPLICATION RECOMMENDATIONS		
Fluid	Recommended Options	Trim Designation Nos.
Air or Industrial Gases (Except O2)	None	ST1, ST2
Oxygen	Opt-55	ST1, ST2
Liquids; Clean, Non-Cavitating, Non-Flashing	None	ST1, ST2
Gas – Clean	None	ST1, ST2
Steam – Saturated & 150 psig (10.3 Barg) or less	None	ST1, ST2, CT2, ST7
Steam – Saturated, 150–400 psig (10.3–27.6 Barg)	None	ST2, ST6
Steam – Superheated	Opt-38HT	ST2, ST6
Hydrocarbon Gas or Liquids	None	ST1, ST2, ST6, CT1, CT2, HT1, HT2, HT7
NACE – Hydrocarbon Gas or Liquid	Opt-40	CT1, CT2
High Temperature Liquids and Gases	Opt-38HT	ST2, ST6
Liquids; Clean, Cavitating, Flashing	Use AC Seal Retainer	ST2, ST6
Liquids; Slurry - Abrasive	Opt-18 included in Trim ST8	ST8
Cryogenic Liquids; Cavitating, Flashing	None	ST2
Cryogenic Gases	None	ST1
Non-Corrosive Chemicals	None	ST1, ST2
Corrosive Chemicals	None	CT1, CT2, HT1, HT2, HT7

TABLE 5 – MAXIMUM CAPACITY - Cv (kv) * FOR SIZING SAFETY RELIEF DEVICE (With Plug @ Approximately 100° Rotation)										
Body Size		Port Size			Port Size			Port Size		
inch	(DN)	Description	Cv	(kv)	Description	Cv	(kv)	Description	Cv	(kv)
1"	(25)	Full	16	(14)	0.4 Reduced	6.0	(5.2)	AC1, LNA	7.9	(6.8)
		0.6 Reduced	10	(8.7)	0.2 Reduced	3.4	(3.0)	AC2, LNB	4.9	(4.2)
1-1/2"	(40)	Full	28	(24)	0.4 Reduced	14	(12)	AC1, LNA	17	(15)
		0.6 Reduced	19	(16)	0.2 Reduced	5.7	(4.9)	AC2, LNB	9.4	(8.1)
2"	(50)	Full	78	(67)	0.4 Reduced	32	(28)	AC1, LNA	32	(28)
		0.6 Reduced	46	(40)	0.2 Reduced	16	(14)	AC2, LNB	18	(16)
3"	(80)	Full	187	(161)	0.4 Reduced	73	(63)	AC1, LNA	63	(54)
		0.6 Reduced	107	(92)	0.2 Reduced	36	(31)	AC2, LNB	35	(30)
4"	(100)	Full	357	(308)	0.4 Reduced	137	(118)	AC1, LNA	120	(104)
		0.6 Reduced	215	(185)	0.2 Reduced	71	(61)	AC2, LNB	68	(59)
6"	(150)	Full	830	(715)	0.4 Reduced	341	(294)	AC1, LNA	220	(190)
		0.6 Reduced	535	(461)	0.2 Reduced	160	(138)	AC2, LNB	123	(106)
8" LF	(200)	Full	785	(677)	0.4 Reduced	341	(294)	AC1, LNA	220	(190)
		0.6 Reduced	535	(461)	0.2 Reduced	160	(138)	AC2, LNB	123	(106)
8" HF	(200)	Full	1260	(1086)	0.3 Reduced	320	(275)	AC1, LNA	325	((280)
		0.5 Reduced	540	(465)				AC2, LNB	220	(189)

* Values indicated are for non-erosive and/or non-corrosive fluid conditions; user must use own safety factors for these severe conditions.

**TABLE 6 – FLOW COEFFICIENTS C_v – STANDARD TRIM
STD (FORWARD) FLOW DIRECTION**

Valve Size	Port	Percent of Plug Open										
		Min.	10%	20%	30%	40%	50%	60%	70%	80%	90%	100%
1" (DN25)	Full Port	0.1	0.8	2.1	3.8	5.5	7.1	8.8	10.1	11.4	12.7	14.0
	0.6 Cv Reduced Port	0.1	0.8	1.8	2.7	3.5	4.6	5.6	6.8	8.0	8.8	9.1
	0.4 Cv Reduced Port	0.1	0.8	1.8	2.7	3.4	4.0	4.4	4.8	5.1	5.4	5.5
	0.2 Cv Reduced Port	0.1	0.4	1.2	1.8	2.2	2.5	2.7	2.9	3.0	3.1	3.1
	LNA	0.1	0.7	1.8	2.9	3.7	4.6	5.1	6.1	6.7	7.0	7.2
	LNB	0.1	0.4	1.1	1.7	2.3	2.8	3.1	3.7	4.1	4.3	4.4
1-1/2" (DN40)	Full Port	0.2	1.7	4.1	7.1	10.3	13.5	16.8	20.3	22.4	23.7	25.0
	0.6 Cv Reduced Port	0.2	1.7	4.2	6.7	9.0	10.9	12.6	14.2	15.2	16.1	16.8
	0.4 Cv Reduced Port	0.2	1.7	3.8	6.2	8.0	9.4	10.4	11.1	11.6	12.0	12.4
	0.2 Cv Reduced Port	0.2	1.7	3.3	4.1	4.5	4.7	4.8	4.9	5.0	5.1	5.2
	LNA	0.2	1.1	3.2	5.5	7.7	9.7	11.8	13.4	14.4	15.1	15.2
	LNB	0.2	0.6	1.8	3.1	4.3	5.5	6.6	7.5	8.1	8.5	8.5
2" (DN50)	Full Port	0.6	6	12	20	27	33	40	45	53	62	71
	0.6 Cv Reduced Port	0.6	3.3	8	12	17	21	25	29	34	38	42
	0.4 Cv Reduced Port	0.6	4.4	7.8	12	15	17	20	23	25	27	29
	0.2 Cv Reduced Port	0.6	3.2	5.5	7.2	9	10	11	12	13	14	14.4
	LNA	0.6	4.4	8.1	11.4	15.2	18.1	20.9	23.8	26	28	29
	LNB	0.6	2.5	4.6	6.4	8.6	10.2	11.8	13.4	14.5	15.5	16.1
3" (DN80)	Full Port	1.4	13	28	43	60	75	90	105	122	144	170
	0.6 Cv Reduced Port	1.4	9	18	29	38	46	56	67	78	88	97
	0.4 Cv Reduced Port	1.4	9	18	26	31	37	42	49	55	61	66
	0.2 Cv Reduced Port	1.4	6.5	12	16	19	23	26	28	30	32	33
	LNA	1.4	10	17	24	30	36	42	48	52	55	57
	LNB	1.4	5.9	9.6	13	17	20	24	27	29	31	32
4" (DN100)	Full Port	2.6	28	57	88	112	136	162	187	218	265	325
	0.6 Cv Reduced Port	2.6	16	31	51	70	95	110	129	152	173	195
	0.4 Cv Reduced Port	2.6	12	26	40	52	63	75	88	104	117	124
	0.2 Cv Reduced Port	2.6	10	20	28	35	40	45	51	57	61	64
	LNA	2.6	18	29	41	55	66	77	88	97	104	109
	LNB	2.6	10	17	23	31	37	43	50	55	58	62
6" (DN150)	Full Port	5.7	25	83	138	217	282	350	423	505	631	760
	0.6 Cv Reduced Port	5.7	33	68	108	151	192	239	299	368	438	486
	0.4 Cv Reduced Port	5.7	28	56	87	119	143	165	202	236	279	310
	0.2 Cv Reduced Port	5.7	16	32	48	66	78	93	109	125	138	145
	LNA	5.7	29	52	74	98	120	143	165	183	194	200
	LNB	5.7	16	29	41	55	67	80	93	103	108	112
8" LF (DN 200)	Full Port	5.7	35	90	150	215	290	350	420	497	620	710
	0.6 Cv Reduced Port	5.7	33	68	108	151	192	239	299	368	438	486
	0.4 Cv Reduced Port	5.7	28	56	87	119	143	165	202	236	279	310
	0.2 Cv Reduced Port	5.7	16	32	48	66	78	93	109	125	138	145
	LNA	5.7	29	52	74	98	120	143	165	183	194	200
	LNB	5.7	16	29	41	55	67	80	93	103	108	112
8" HF (DN 200)	Full Port	1.4	50	150	250	360	470	580	690	840	1050	1260
	0.5 Cv Reduced Port	2.2	30	90	150	220	270	320	370	450	510	540
	0.3 Cv Reduced Port	11.5	40	90	120	170	200	220	260	290	310	320

NOTE: See Graph No. 1 for corresponding F_L factors.

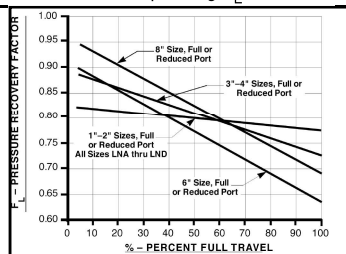

Graph No. 1

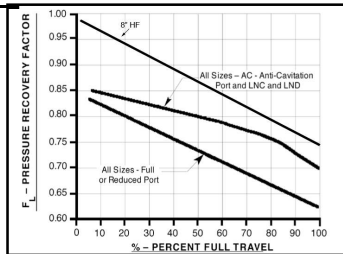

Graph No. 2

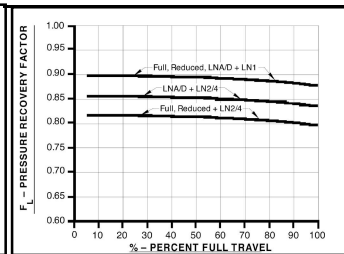

Graph No. 3

**TABLE 7 – FLOW COEFFICIENTS C_v – STANDARD TRIM
REVERSE FLOW DIRECTION**

Valve Size	Port	Percent of Plug Open										
		Min.	10%	20%	30%	40%	50%	60%	70%	80%	90%	100%
1" (DN25)	Full Port	0.1	1.4	2.8	4.2	5.6	7.0	8.4	9.8	11.2	12.6	14.0
	0.6 Cv Reduced Port	0.1	1.1	1.8	2.7	3.6	4.6	5.5	6.4	7.3	8.2	9.1
	0.4 Cv Reduced Port	0.1	.8	1.1	1.7	2.2	2.8	3.3	3.9	4.4	5.0	5.5
	0.2 Cv Reduced Port	0.1	.6	.6	.9	1.2	1.6	1.9	2.2	2.5	2.8	3.1
1-1/2" (DN40)	Full Port	0.2	2.5	5.0	7.5	10.0	12.5	15.0	17.5	20.0	22.5	25.0
	0.6 Cv Reduced Port	0.2	2.0	3.4	5.0	6.7	8.4	10.1	11.8	13.4	15.1	16.8
	0.4 Cv Reduced Port	0.2	1.9	2.5	3.7	5.0	6.2	7.4	8.7	9.9	11.2	12.4
	0.2 Cv Reduced Port	0.2	.9	1.0	1.6	2.1	2.6	3.1	3.6	4.2	4.7	5.2
2" (DN50)	Full Port	0.6	7.1	14	21	28	36	43	50	57	64	71
	0.6 Cv Reduced Port	0.6	5.0	8.4	13	17	21	25	29	34	38	42
	0.4 Cv Reduced Port	0.6	4.4	5.8	8.7	12	15	17	20	23	26	29
	0.2 Cv Reduced Port	0.6	2.5	2.8	4.2	5.6	7.0	8.4	9.8	11.2	12.6	14.0
3" (DN80)	Full Port	1.3	14	30	45	62	77	91	105	121	142	166
	0.6 Cv Reduced Port	1.3	10	19	30	39	47	57	67	78	87	97
	0.4 Cv Reduced Port	1.3	10	19	27	32	38	43	49	55	60	66
	0.2 Cv Reduced Port	1.3	6.9	13	17	20	24	26	28	30	32	33
4" (DN100)	Full Port	2.5	29	59	90	113	136	160	184	212	255	310
	0.6 Cv Reduced Port	2.6	17	33	53	72	97	112	130	151	167	195
	0.4 Cv Reduced Port	2.5	13	27	42	54	65	76	88	104	113	124
	0.2 Cv Reduced Port	2.6	11	21	29	36	41	46	51	57	59	64
6" (DN150)	Full Port	5.9	40	83	138	217	282	345	416	491	607	724
	0.6 Cv Reduced Port	5.9	33	67	105	145	183	225	279	341	402	442
	0.4 Cv Reduced Port	5.6	28	55	84	114	136	156	189	219	256	282
	0.2 Cv Reduced Port	5.3	16	31	47	63	74	88	102	116	127	132
8" LF (DN 200)	Full Port	5.2	35	88	146	207	276	330	393	460	569	648
	0.6 Cv Reduced Port	5.9	33	67	105	145	183	225	279	341	402	442
	0.4 Cv Reduced Port	5.6	28	55	84	114	136	156	189	219	256	282
	0.2 Cv Reduced Port	5.3	16	31	47	63	74	88	102	116	127	132
8" HF (DN 200)	Full Port	5	40	130	240	350	450	550	670	800	940	1130
	0.5 Cv Reduced Port	7	40	90	150	220	290	360	440	520	580	640
	0.3 Cv Reduced Port	4.7	40	80	120	160	200	230	270	310	340	355

NOTE: See Graph No. 2 for corresponding F_L factors.

**TABLE 8 – FLOW COEFFICIENTS C_v – ANTI-CAVITATION TRIM
REVERSE FLOW DIRECTION**

Valve Size	Port	Percent of Plug Open										
		Min.	10%	20%	30%	40%	50%	60%	70%	80%	90%	100%
1" (DN25)	AC1	0.4	.7	1.9	3.0	3.9	4.8	5.4	6.4	7.1	7.4	7.6
	AC2	0.2	0.4	1.2	1.8	2.4	2.9	3.3	3.9	4.4	4.5	4.7
1-1/2" (DN40)	AC1	0.7	1.0	3.0	5.2	7.3	9.2	11.2	12.7	13.7	14.3	14.4
	AC2	0.4	0.6	1.7	2.9	4.1	5.2	6.3	7.2	7.7	8.0	8.1
2" (DN50)	AC1	1.5	4.6	8.5	12	16	19	22	25	27	29	30
	AC2	0.9	2.6	4.8	6.8	9.0	11	12	14	15	16	17
3" (DN80)	AC1	3.0	11	18	25	32	38	44	50	55	58	60
	AC2	1.7	6.2	10	14	18	21	25	28	31	33	34
4" (DN100)	AC1	5.8	19	31	43	58	69	81	93	102	109	115
	AC2	3.3	11	18	24	33	39	46	52	58	61	65
6" & 8" (DN150 & 200)	AC1	10.5	30	55	78	103	126	151	174	193	204	210
	AC2	5.9	17	31	44	58	71	85	97	108	114	118
8" HF (DN 200)	AC1	15.8	45	85	130	170	210	250	275	305	320	325
	AC2	17.2	40	60	90	125	155	180	200	210	215	220

NOTE: See Graph No. 2 for corresponding F_L factors.

**TABLE 9 – FLOW COEFFICIENTS C_V – LO-NOISE TRIM
STD (FORWARD) FLOW DIRECTION**

Valve Size	Trim Insert	Port	Percent of Plug Travel											
			Min.	10%	20%	30%	40%	50%	60%	70%	80%	90%	100%	
1-1/2" (DN40)	LN2	Full	0.2	1.7	4.0	6.7	9.2	11.2	12.9	14.2	14.9	15.3	15.6	
		0.6 Reduced	0.3	1.7	4.1	6.4	8.2	9.6	10.7	11.6	12.1	12.5	12.9	
		0.4 Reduced	0.3	1.7	3.7	5.9	7.4	8.5	9.2	9.7	10.0	10.3	10.5	
		0.2 Reduced	0.3	1.7	3.3	4.0	4.4	4.6	4.7	4.8	4.9	4.9	5.0	
		LNA	0.4	1.1	3.1	5.3	7.2	8.7	10.2	11.1	11.7	12.0	12.1	
		LNB	0.3	0.6	1.8	3.0	4.2	5.3	6.3	7.1	7.5	7.8	7.9	
2" (DN50)	LN2	Full	0.3	5.8	10.8	15.6	18.3	19.9	21.2	21.9	22.6	23.2	23.6	
		0.6 Reduced	0.4	3.3	7.6	10.8	14.1	16.1	17.7	18.9	20.1	20.9	21.5	
		0.4 Reduced	0.5	4.3	7.4	10.8	12.9	14.1	15.6	16.9	17.7	18.3	18.9	
		0.2 Reduced	0.8	3.2	5.4	6.9	8.5	9.3	10.1	10.8	11.5	12.2	12.5	
		LNA	0.6	4.3	7.7	10.4	13.0	14.6	16.0	17.2	17.9	18.5	18.8	
		LNB	0.5	2.5	4.5	6.2	8.1	9.4	10.7	11.8	12.5	13.2	13.5	
3" (DN80)	LN2	Full	0.8	13	26	36	44	50	53	56	58	60	62	
		0.6 Reduced	1.1	9	17	27	33	38	43	47	50	53	55	
		0.4 Reduced	1.3	9	17	24	28	32	35	39	42	45	47	
		0.2 Reduced	2.0	6.5	12	16	18	22	24	26	27	29	30	
	LN3	Full	0.5	12	24	31	36	39	40	41	42	43	44	
		0.6 Reduced	0.8	8.8	17	24	29	32	35	37	39	40	41	
		0.4 Reduced	1.1	8.8	17	23	26	29	31	33	35	36	37	
			0.2 Reduced	1.8	6.4	12	15	18	20	23	24	25	26	27
	LN2	LNA	1.4	10	17	22	28	32	35	39	41	42	43	43
		LNB	1.2	5.9	9.5	13	17	19	22	25	27	28	29	
LN3	LNA	1.2	10	16	21	25	28	31	33	34	35	35	35	
	LNB	1.0	5.8	9.4	13	16	19	21	23	25	26	26		
4" (DN100)	LN2	Full	1.1	27	48	63	70	75	79	81	83	85	87	
		0.6 Reduced	1.6	16	29	44	55	65	70	74	77	80	82	
		0.4 Reduced	2.1	12	25	37	45	52	58	63	68	71	73	
		0.2 Reduced	3.5	10	20	27	33	37	40	44	48	50	52	
	LN3	Full	0.8	26	43	53	57	59	61	62	63	64	65	
		0.6 Reduced	1.3	16	28	40	48	54	57	59	61	62	63	
		0.4 Reduced	1.7	12	24	34	41	46	50	53	56	57	58	
			0.2 Reduced	3.1	10	19	26	31	34	37	40	43	45	46
	LN4	Full	1.3	27	51	70	80	87	93	97	101	105	108	
		0.6 Reduced	2.0	16	30	47	60	73	79	85	91	95	98	
		0.4 Reduced	2.4	12	25	38	47	55	63	70	77	82	84	
			0.2 Reduced	3.7	10	20	27	33	38	42	47	51	54	56
	LN2	LNA	2.3	18	28	37	47	53	58	63	66	68	69	
		LNB	2.0	10	16	22	29	34	39	44	47	49	51	
	LN3	LNA	1.9	17	27	35	42	47	50	53	55	56	56	
		LNB	1.8	10	16	22	28	32	36	40	42	44	45	
LN4	LNA	2.6	18	29	38	50	57	64	70	74	77	79		
	LNB	2.2	10	16	23	30	35	41	46	49	52	54		
6" & 8" LF (DN150 & 200)	LN2	Full	2.4	34	82	120	146	165	174	181	186	190	193	
		0.6 Reduced	3.7	33	64	95	121	139	153	166	176	182	185	
		0.4 Reduced	4.8	28	54	80	102	116	127	142	153	163	168	
		0.2 Reduced	7.8	16	32	47	63	73	84	96	106	114	117	
	LN3	Full	1.6	34	75	100	113	121	124	127	128	130	131	
		0.6 Reduced	2.6	32	61	84	100	109	116	122	125	127	128	
		0.4 Reduced	3.5	27	52	73	89	97	104	111	116	120	122	
		0.2 Reduced	6.5	16	31	45	59	67	76	84	91	96	98	
	LN4	Full	3.0	35	85	129	163	190	204	215	224	233	237	
		0.6 Reduced	4.5	33	66	99	129	152	173	192	207	218	223	
		0.4 Reduced	5.6	28	55	82	108	124	138	157	172	187	195	
			0.2 Reduced	8.4	16	32	47	64	74	87	100	112	121	126
	LN2	LNA	4.7	28	51	69	88	103	117	127	135	139	141	
		LNB	3.9	16	29	41	53	64	75	84	91	95	97	
	LN3	LNA	3.7	28	49	65	79	89	98	104	108	110	111	
		LNB	3.4	16	29	40	51	60	69	76	81	84	86	
LN4	LNA	5.2	28	51	71	91	108	125	138	148	153	156		
	LNB	4.1	16	29	41	54	65	76	87	95	100	102		

NOTES: 1. See Graph No. 3 for corresponding F_L factors.
2. See Table 5 for C_V 's of LNA or LNB in std. flow direction with NO insert.

MOUNTED ACCESSORY SPECIFICATIONS

Positioners: General. Mounted to arm housing. All feedback linkage is enclosed and not exposed directly to elements.

P/P Pneumatic. Model 73. Adjustable zero only. Analog signal only. Includes gauge port, with gauge. Not Available on 8" HF.

General: PMV Positioners. Aluminum housing with corrosion resistant powder coated epoxy. Pneumatic output load as required by actuator bench range. Field reversible action. Mounting dimensions per IEC 60534-6-2 Standard.

P/P Pneumatic. Model P5 features SST cam with a simple cam locking device, tapped exhaust port for venting media, external zero adjustment. Input signal 3-15 psig, Includes gauge ports, no gauges. Analog only.

I/P Electro-Pneumatic. Model D20 is Digital and Hart compatible. Features single button self-calibration. input signal 4-20mA. Optional gauge block with gauges for Models D20 D and D20 I.

Model D20 D is general purpose.

Model D20 I is Intrinsically safe, ATEX Ex ia IIC T4, FM CLS 1 DIV 1, FM Non-incendive CLS 1 DIV 2.

Model D20 E is ATEX EEX d IIB+H₂, T6 FM Approved. Gauge block is built in, no gauges. Not available with limit switch option.

I/P Electro-Pneumatic. Model D3 is Digital, Hart, Profibus, and Fieldbus compatible. Input signal 4-20mA. Features large graphic display. Optional gauge block for Models D3 X and D3 I, no gauges.

Model D3 X is general purpose.

Model D3 I is Intrinsically safe, ATEX EEX ia IIC T4.

Model D3 E is ATEX EEX d IIB+H₂, T6 CSA CLS 1 DIV 1 FM CLS 1 DIV 1

Gauge block is built in, no gauges. Not available with limit switch option.

Model PS2 is Hart, Fieldbus and Profibus compatible. Input signal 4-20mA. Features a Makrolon housing, (Aluminum for

Explosion Proof.) Mounting dimensions per IEC 60534-6-2 Standard.

Model PS2-1 is general purpose.

Model PS2-2 is Intrinsically safe, ATEX Ex ia IIC T6/T4, FM CLS 1 DIV 1, CSA CLS 1 DIV 1, SIL 2

Model PS2-3 EX d IIC T6/T4, SIL 2. Not available with limit switch option.

All I/P positioners not available with 764's.

Air Tubing: Instrument air tubing SST with SST fittings.

Airset: Model 5200P instrument air supply regulator. Use with positioners. Bracket mounted to actuator casing. Supplied with gauge. See technical bulletin 5200P-TB.

Solenoid Valve: Standard Brass: Available in standard weather-proof model. Brass body, 1/4" female NPT connections. Nipple mounted to actuator casing. 120 VAC, 60 Hz power supply, CSA Approved Class 3221-01, NEMA 2,3,3S,4,4X. 8" HF utilizes a direct mount NAMUR mount style.

X-Proof or SST construction: Consult Factory.

Standard installation vents actuator and drives valve to fail-safe position upon loss of electrical power.

Consult factory for 230/1/50, or 120 VDC power supplies, or intrinsically safe (IS) service.

Transducers FM, CSA approved NEMA 4X CI 1, Div 1 and CI 1, Div 2

Other Accessories: 764 P/PD pressure controller. Lockup valve. Position transmitter.

Limit Switches: Model- D20 and D3 positioners, switches are available, unit is enclosed in the positioner housing.

Limit and proximity switch options not available on Explosion proof rated positioners.

FIGURE 11a - 1" - 8" LF Mounting Positions

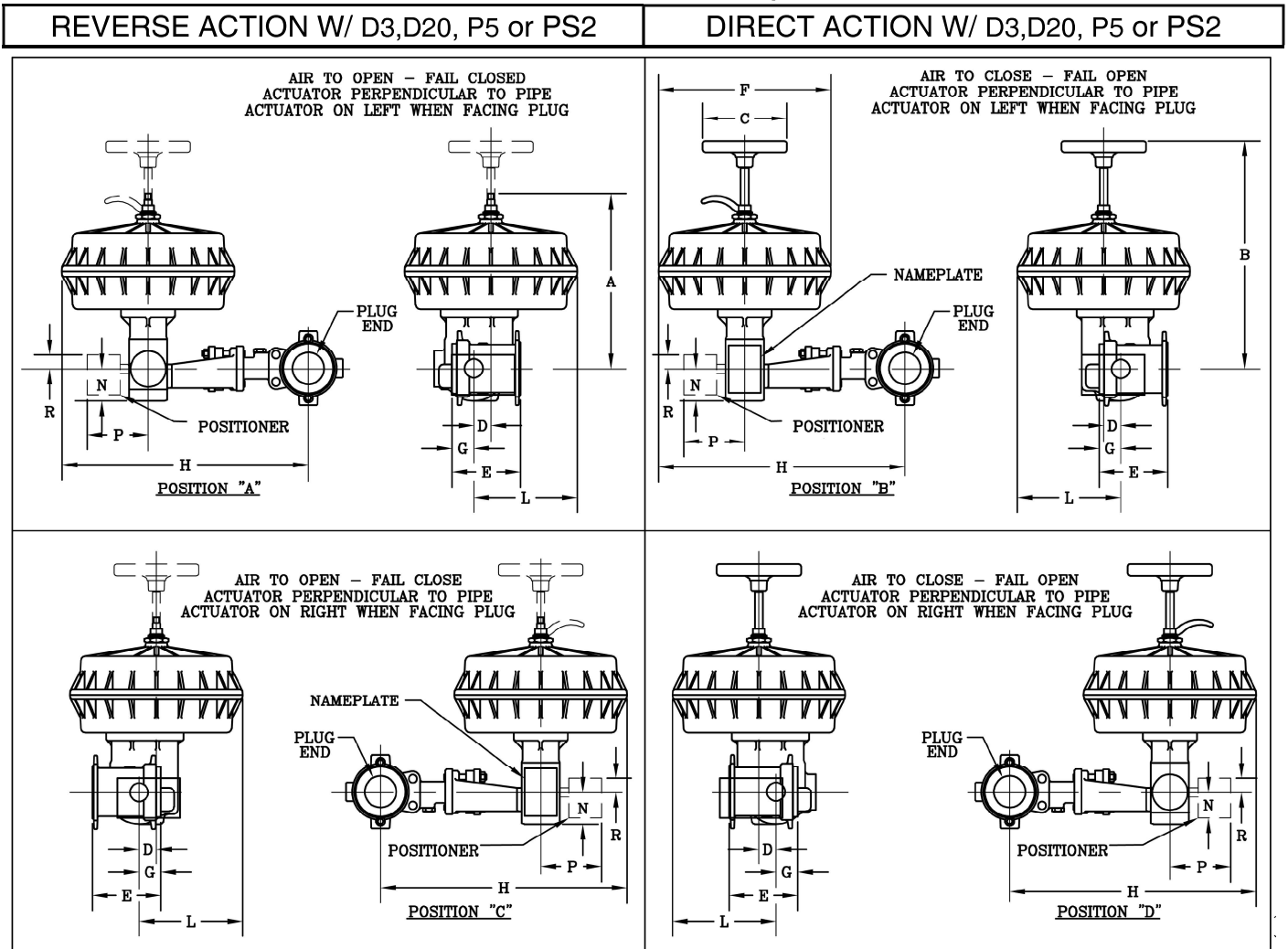

Dimensions in Inches $\pm 0.06"$											Wt - lbs		* W / Accessories					
NPS	A	B	C	D	E	F	G	H	L	N	No Flgs	W/ Flgs	F Max	H Max	L Max	N Max	P Max	R Max
1	13.31	16.56	4.00	1.19	4.00	10.50	1.08	14.75	6.44	2.50	39	46	21.42	20.21	11.90	3.69	8.60	3.18
1 1/2	13.31	16.56	4.00	1.19	4.50	10.50	1.42	15.19	6.44	2.50	41	54	21.42	20.21	11.90	3.69	8.60	3.18
2	13.31	16.56	4.00	1.19	4.88	10.50	1.42	15.19	6.44	2.50	45	59	21.42	20.21	11.90	3.69	8.60	3.18
3	16.56	21.62	8.00	1.62	6.50	16.38	2.05	23.38	9.81	3.00	93	119	27.44	28.91	15.34	3.69	8.56	3.18
4	16.56	21.62	8.00	1.62	7.62	16.38	2.61	23.94	9.81	3.00	115	149	27.44	29.47	15.34	3.69	8.56	3.18
6	16.56	21.62	8.00	1.62	9.00	16.38	4.00	25.00	9.81	3.00	168	222	27.44	30.53	15.34	3.69	8.56	3.18
8	16.56	21.62	8.00	1.62	9.56	16.38	4.00	25.00	9.81	3.00	223	320	27.44	30.53	15.34	3.69	8.56	3.18

Dimensions in Millimeters ± 1.6 MM											Wt - kgs		* W / Accessories					
(DN)	A	B	C	D	E	F	G	H	L	N	No Flgs	W/ Flgs	F Max	H Max	L Max	N Max	P Max	R Max
(25)	338	421	102	30	102	267	27	375	164	64	18	21	544	513	302	94	218	81
(40)	338	421	102	30	114	267	36	386	164	64	19	24	544	525	302	94	218	81
(50)	338	421	102	30	124	267	36	386	164	64	21	27	544	525	302	94	218	81
(80)	421	549	203	41	165	416	52	594	249	76	42	54	697	734	390	94	217	81
(100)	421	549	203	41	194	416	66	608	249	76	52	67	697	749	390	94	217	81
(150)	421	549	203	41	229	416	102	635	249	76	76	100	697	776	390	94	217	81
(200)	421	549	203	41	243	416	102	635	249	76	101	145	697	775	390	94	217	81

* Accessories like Solenoid Valve, and/or Positioner or Transduce or 764P Controller or 5200 Airset

FIGURE 11b - 1" - 8" LF Mounting Positions

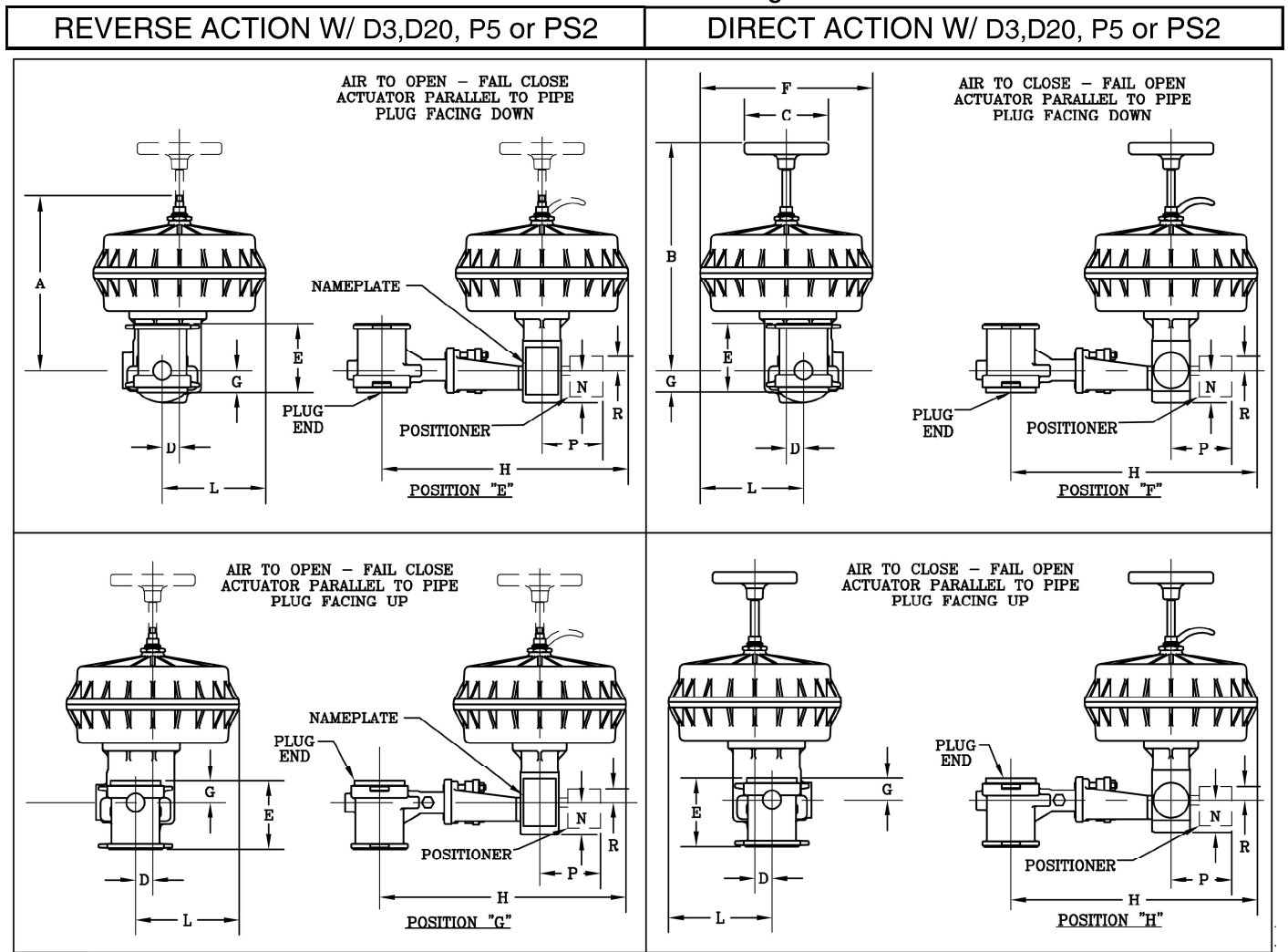

Dimensions in Inches ± 0.06"											Wt - lbs		* W / Accessories					
NPS	A	B	C	D	E	F	G	H	L	N	No Flgs	W/ Flgs	F Max	H Max	L Max	N Max	P Max	R Max
1	13.31	16.56	4.00	1.19	4.00	10.50	1.08	14.75	6.44	2.50	39	46	21.42	20.21	11.90	3.69	8.60	3.18
1 1/2	13.31	16.56	4.00	1.19	4.50	10.50	1.42	15.19	6.44	2.50	41	54	21.42	20.21	11.90	3.69	8.60	3.18
2	13.31	16.56	4.00	1.19	4.88	10.50	1.42	15.19	6.44	2.50	45	59	21.42	20.21	11.90	3.69	8.60	3.18
3	16.56	21.62	8.00	1.62	6.50	16.38	2.05	23.38	9.81	3.00	93	119	27.44	28.91	15.34	3.69	8.56	3.18
4	16.56	21.62	8.00	1.62	7.62	16.38	2.61	23.94	9.81	3.00	115	149	27.44	29.47	15.34	3.69	8.56	3.18
6	16.56	21.62	8.00	1.62	9.00	16.38	4.00	25.00	9.81	3.00	168	222	27.44	30.53	15.34	3.69	8.56	3.18
8	16.56	21.62	8.00	1.62	9.56	16.38	4.00	25.00	9.81	3.00	223	320	27.44	30.53	15.34	3.69	8.56	3.18

Dimensions in Millimeters ± 1.6 MM											Wt - kgs		* W / Accessories					
(DN)	A	B	C	D	E	F	G	H	L	N	No Flgs	W/ Flgs	F Max	H Max	L Max	N Max	P Max	R Max
(25)	338	421	102	30	102	267	27	375	164	64	18	21	544	513	302	94	218	81
(40)	338	421	102	30	114	267	36	386	164	64	19	24	544	525	302	94	218	81
(50)	338	421	102	30	124	267	36	386	164	64	21	27	544	525	302	94	218	81
(80)	421	549	203	41	165	416	52	594	249	76	42	54	697	734	390	94	217	81
(100)	421	549	203	41	194	416	66	608	249	76	52	67	697	749	390	94	217	81
(150)	421	549	203	41	229	416	102	635	249	76	76	100	697	776	390	94	217	81
(200)	421	549	203	41	243	416	102	635	249	76	101	145	697	775	390	94	217	81

* Accessories like Solenoid Valve, and/or Positioner or Transduce or 764P Controller or 5200 Airset

FIGURE 11c - 1" - 8" LF Mounting Positions

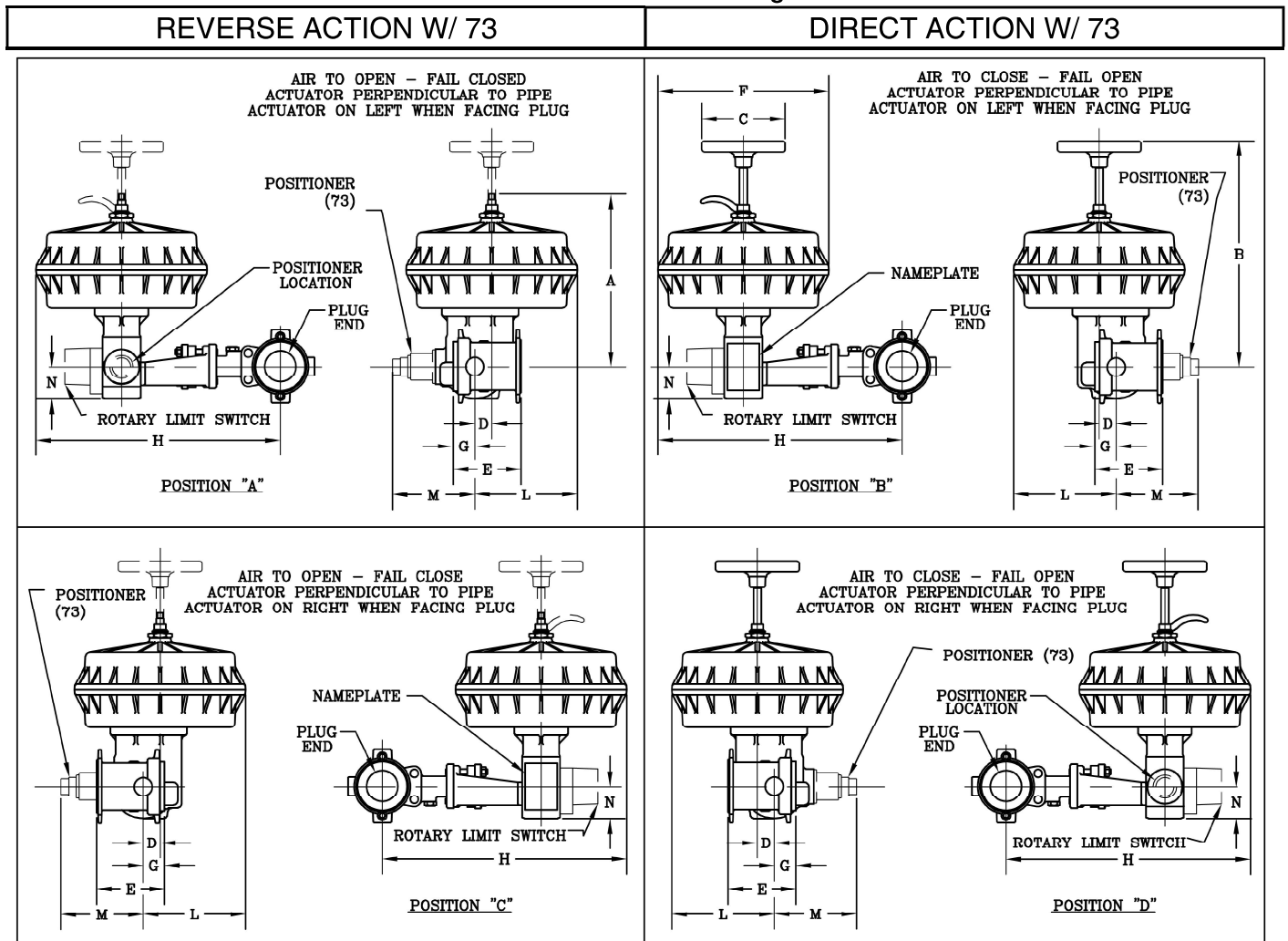

Dimensions in Inches $\pm 0.06''$												Wt - lbs		* W / Accessories			
NPS	A	B	C	D	E	F	G	H	L	M	N	No Flgs	W/ Flgs.	F Max	H Max	L Max	N Max
1	13.31	16.56	4.00	1.19	4.00	10.50	1.08	14.75	6.44	9.13	2.50	39	46	21.42	20.21	11.90	2.50
1 1/2	13.31	16.56	4.00	1.19	4.50	10.50	1.42	15.19	6.44	9.13	2.50	41	54	21.42	20.65	11.90	2.50
2	13.31	16.56	4.00	1.19	4.88	10.50	1.42	15.19	6.44	9.13	2.50	45	59	21.42	20.65	11.90	2.50
3	16.56	21.62	8.00	1.62	6.50	16.38	2.05	23.38	9.81	9.13	3.00	93	119	27.44	28.91	15.34	3.00
4	16.56	21.62	8.00	1.62	7.62	16.38	2.61	23.94	9.81	9.13	3.00	115	149	27.44	29.47	15.34	3.00
6	16.56	21.62	8.00	1.62	9.00	16.38	4.00	25.00	9.81	9.13	3.00	168	222	27.44	30.53	15.34	3.00
8	16.56	21.62	8.00	1.62	9.56	16.38	4.00	25.00	9.81	9.13	3.00	223	320	27.44	30.53	15.34	3.00

Dimensions in Millimeters ± 1.6 MM												Wt - kgs		* W / Accessories			
(DN)	A	B	C	D	E	F	G	H	L	M	N	No Flgs	W/ Flgs.	F Max	H Max	L Max	N Max
(25)	338	421	102	30	102	267	27	375	164	232	64	18	21	544	513	302	64
(40)	338	421	102	30	114	267	36	386	164	232	64	19	24	544	525	302	64
(50)	338	421	102	30	124	267	36	386	164	232	64	21	27	544	525	302	64
(80)	421	549	203	41	165	416	52	594	249	232	76	42	54	697	734	390	76
(100)	421	549	203	41	194	416	66	608	249	232	76	52	67	697	749	390	76
(150)	421	549	203	41	229	416	102	635	249	232	76	76	100	697	776	390	76
(200)	421	549	203	41	243	416	102	635	249	232	76	101	145	697	776	390	76

* Accessories like Solenoid valve, and/or Rotary Limit Switch or Positioner or Transducer or 764P Controller or Airster

FIGURE 11d - 1" - 8" LF Mounting Positions

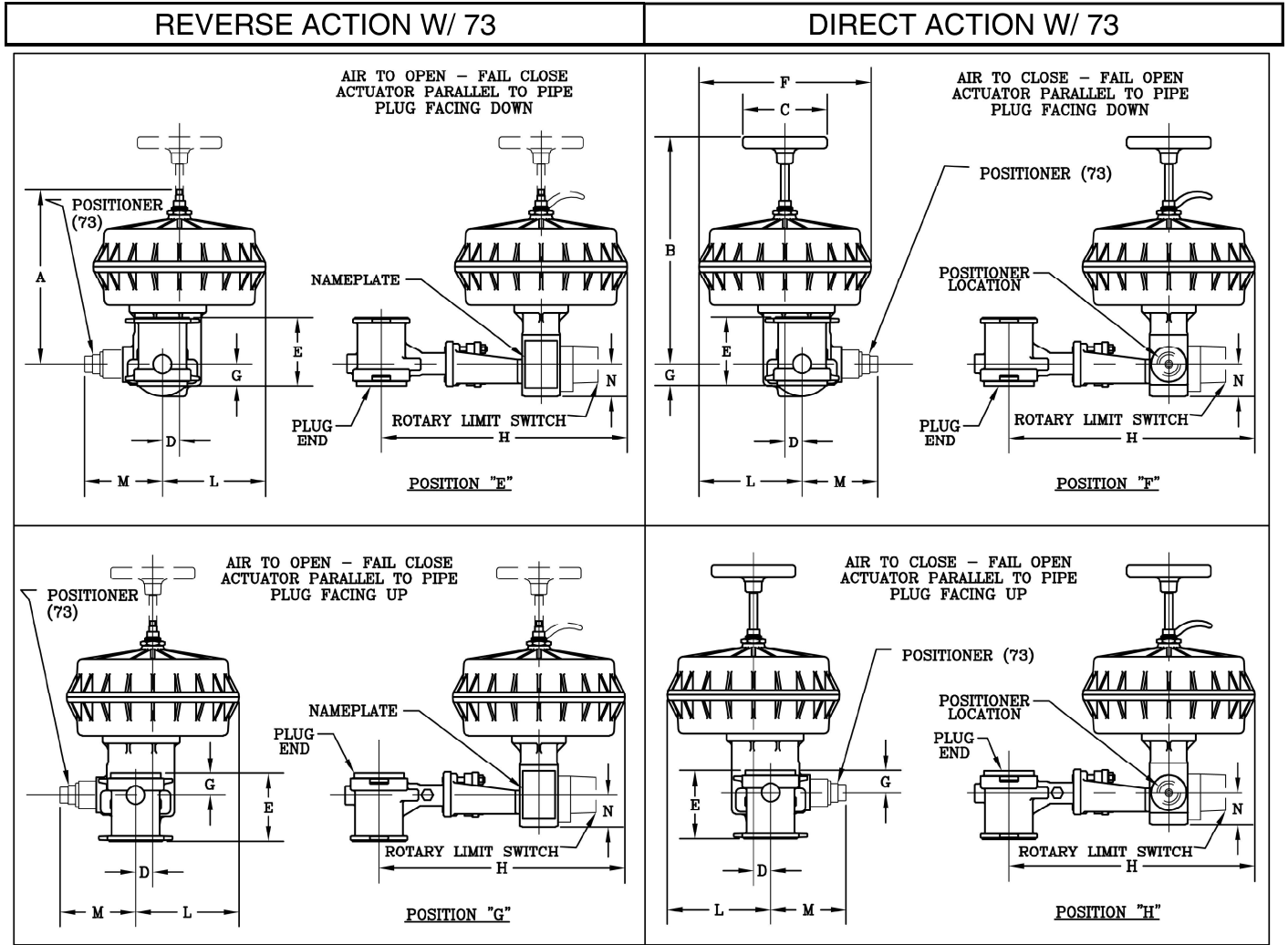

Dimensions in Inches $\pm 0.06"$												Wt - lbs		* W / Accessories			
NPS	A	B	C	D	E	F	G	H	L	M	N	No Flgs	W/ Flgs.	F Max	H Max	L Max	N Max
1	13.31	16.56	4.00	1.19	4.00	10.50	1.08	14.75	6.44	9.13	2.50	39	46	21.42	20.21	11.90	2.50
1 1/2	13.31	16.56	4.00	1.19	4.50	10.50	1.42	15.19	6.44	9.13	2.50	41	54	21.42	20.65	11.90	2.50
2	13.31	16.56	4.00	1.19	4.88	10.50	1.42	15.19	6.44	9.13	2.50	45	59	21.42	20.65	11.90	2.50
3	16.56	21.62	8.00	1.62	6.50	16.38	2.05	23.38	9.81	9.13	3.00	93	119	27.44	28.91	15.34	3.00
4	16.56	21.62	8.00	1.62	7.62	16.38	2.61	23.94	9.81	9.13	3.00	115	149	27.44	29.47	15.34	3.00
6	16.56	21.62	8.00	1.62	9.00	16.38	4.00	25.00	9.81	9.13	3.00	168	222	27.44	30.53	15.34	3.00
8	16.56	21.62	8.00	1.62	9.56	16.38	4.00	25.00	9.81	9.13	3.00	223	320	27.44	30.53	15.34	3.00

Dimensions in Millimeters ± 1.6 MM												Wt - kgs		* W / Accessories			
(DN)	A	B	C	D	E	F	G	H	L	M	N	No Flgs	W/ Flgs	F Max	H Max	L Max	N Max
(25)	338	421	102	30	102	267	27	375	164	232	64	18	21	544	513	302	64
(40)	338	421	102	30	114	267	36	386	164	232	64	19	24	544	525	302	64
(50)	338	421	102	30	124	267	36	386	164	232	64	21	27	544	525	302	64
(80)	421	549	203	41	165	416	52	594	249	232	76	42	54	697	734	390	76
(100)	421	549	203	41	194	416	66	608	249	232	76	52	67	697	749	390	76
(150)	421	549	203	41	229	416	102	635	249	232	76	76	100	697	776	390	76
(200)	421	549	203	41	243	416	102	635	249	232	76	101	145	697	776	390	76

* Accessories like Solenoid valve, and/or Rotary Limit Switch or Positioner or Transducer or 764P Controller or Airset

FIGURE 11e - 8" HF Mounting Positions

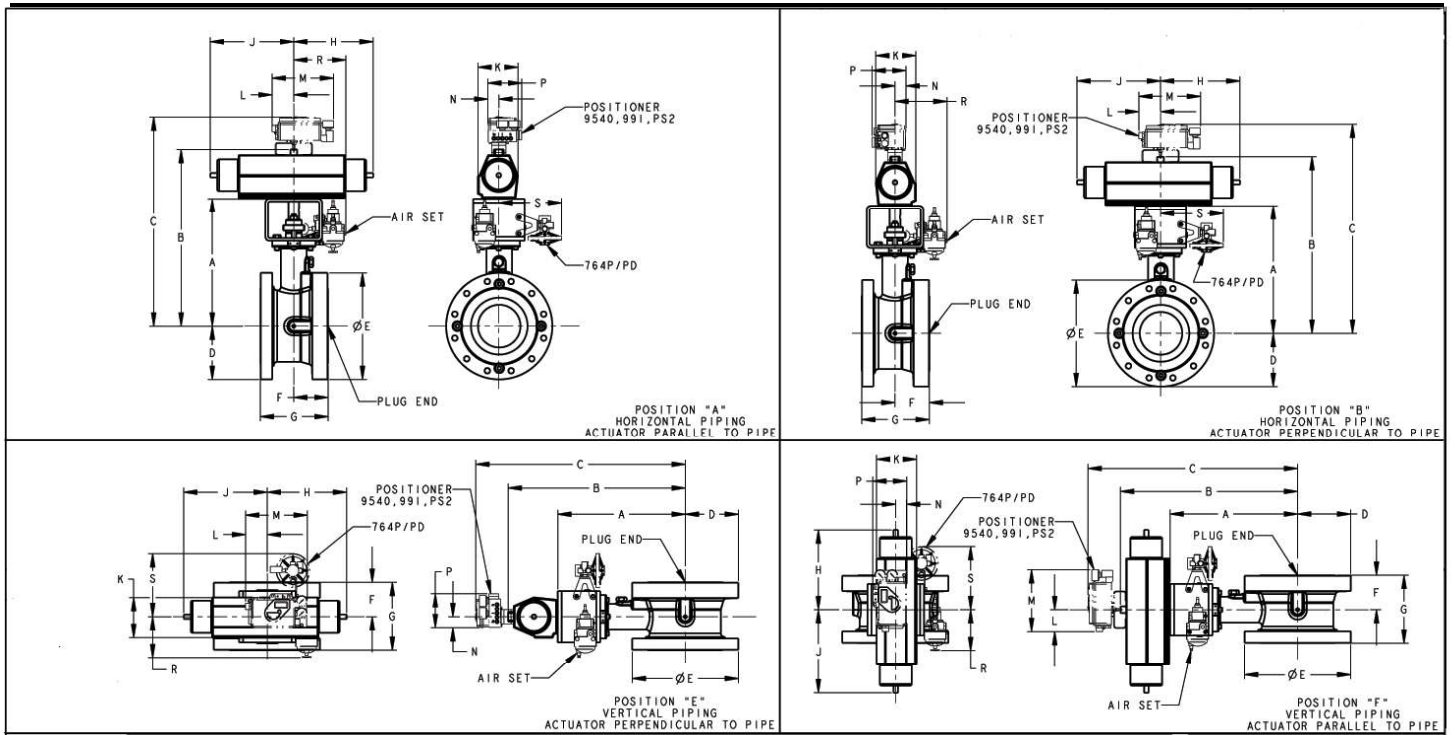

Dimensions in Inches $\pm 0.06"$ (mm ± 1.52 mm)

Actuator	A	B	C Max	D 150#	D 300#	E 150#	E 300#	F	G	H	J	K
0-100 PSID	18.02 (457.7)	24.91 (632.7)	29.69 (754.1)	6.75 (171.5)	7.50 (190.5)	13.50 (342.9)	15.00 (381.0)	4.84 (122.9)	9.56 (242.8)	11.81 (300.0)	11.22 (285.0)	5.67 (144.0)
101-200 PSID	18.02 (457.7)	26.75 (679.5)	31.53 (800.9)	6.75 (171.5)	7.50 (190.5)	13.50 (342.9)	15.00 (381.0)	4.84 (122.9)	9.56 (242.8)	12.48 (317.0)	12.48 (317.0)	6.00 (152.4)
201-325 PSID	18.02 (457.7)	28.96 (735.6)	33.74 (857.0)	6.75 (171.5)	7.50 (190.5)	13.50 (342.9)	15.00 (381.0)	4.84 (122.9)	9.56 (242.8)	20.08 (510.0)	5.70 (144.8)	8.66 (220.0)

Actuator	Wt - lbs (kg)		* W / Accessories						
	150# RF	300# RF	L Max	M Max	N Max	P Max	R Pos A & B	R Pos E & F	S
0-100 PSID	259 (117.4)	302 (136.9)	4.17 (105.9)	9.67 (254.6)	1.87 (47.5)	4.02 (102.1)	7.35 (186.7)	5.78 (146.8)	8.88 225.6
101-200 PSID	279 (126.5)	322 (146.0)	4.17 (105.9)	9.67 (254.6)	1.87 (47.5)	4.02 (102.1)	7.35 (186.7)	5.78 (146.8)	8.88 225.6
201-325 PSID	321 (145.6)	364 (165.1)	4.17 (105.9)	9.67 (254.6)	1.87 (47.5)	4.02 (102.1)	7.35 (186.7)	5.78 (146.8)	8.88 225.6

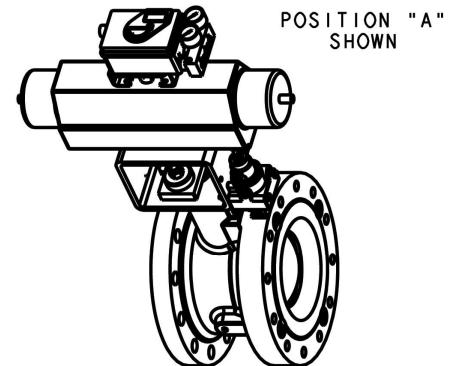
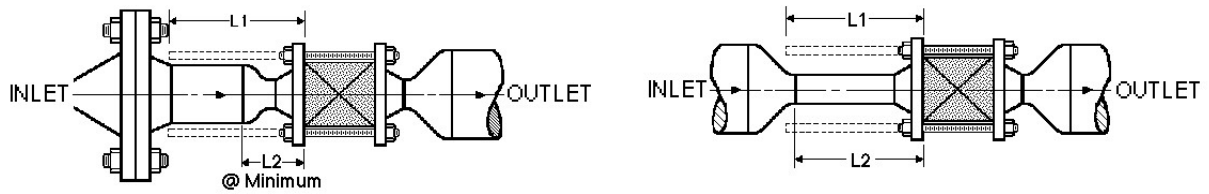

FIGURE 12:
“FLANGELESS” BODY DESIGN LINE BOLTING REMOVAL CLEARANCE



NOTE: Locate spool piece between Inlet ange and reducer. DO NOT locate spool at Outlet ange.

Body Size inch (DN)	Reducer Size	150# Flgs.		300# Flgs.		600# Flgs.	
		L1	L2	L1	L2	L1	L2
1" (25)	None	8.38 (213)	Min	8.75 (222)	Min	8.94 (227)	Min
	1-1/2"x1"		Min				
	2"x1"		Min				
	2-1/2"x1"		7.38 (187)				
1-1/2" (40)	None	8.44 (214)	Min	9.88 (251)	Min	10.12 (257)	Min
	2"x1-1/2"		Min		Min		
	2-1/2"x1-1/2"		Min		Min		
	3"x1-1/2"		Min		Min		
	4"x1-1/2"		7.44 (198)		8.88 (226)		9.12 (232)
2" (50)	None	10.06 (256)	Min	10.13 (257)	Min	10.50 (267)	Min
	2-1/2"x2"		Min				
	3"x2"		Min				
	4"x2"		9.00 (229)				
3" (80)	None	11.50 (292)	Min	13.44 (341)	Min	13.88 (353)	Min
	4"x3"		Min		Min		
	6"x3"		10.25 (260)		12.19 (310)		12.63 (321)
4" (100)	None	12.50 (318)	Min	13.56 (344)	Min	16.00 (406)	Min
	6"x4"		Min		Min		
	8"x4"		11.00 (279)		12.00 (305)		14.50 (368)
	10" x 4"						
6" (150)	None	14.81 (376)	Min	16.25 (413)	Min	N/A	N/A
	8"x6"		Min		Min		
	10"x6"		Min		Min		
	12"x6"		12.75 (324)		14.00 (356)		N/A
	14"x6"						
8" LF (200)	None	15.50 (394)	Min	18.75 (476)	Min	N/A	N/A
	10"x8"		Min		Min		
	12"x8"		Min		Min		
	14"x8"		13.43 (341)		16.68 (424)		N/A
	16"x8"						

FIGURE 13:
FRONT FLANGE BOLT HOLE DESIGN

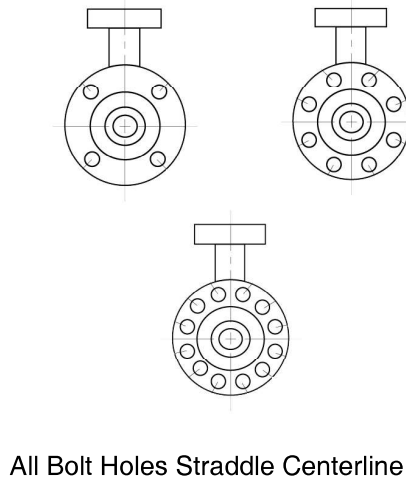

Body Size in (DN)	Pres- sure Class	All Front Flange Bolt Holes Drilled and Tapped	
		Total #	Threads *
1" (25)	150	4	1/2"-13UNC
	300/600	4	5/8"-11UNC
1-1/2" (40)	150	4	1/2"-13UNC
	300/600	4	3/4"-10UNC
2" (50)	150	4	5/8"-11UNC
	300/600	8	5/8"-11UNC
3" (80)	150	4	5/8"-11UNC
	300/600	8	3/4"-10UNC
4" (100)	150	8	5/8"-11UNC
	300	8	3/4"-10UNC
	600	N/A	N/A
6" (150)	150	8	3/4"-10UNC
	300	8	3/4"-10UNC
	600	N/A	N/A
8" LF (200)	150	8	3/4"-10UNC
	300	12	7/8"-9UNC
	600	N/A	N/A
8" HF (200)	150	8	3/4"-10UNC
	300	12	7/8"-9UNC

"N/A" = Not available
* Hole Threads also available in Metric units.

OPTION FOR ISO 5211 ACTUATOR FLANGE MOUNT:
(YOKE ON THE RANGER BODY ASSEMBLY IS MACHINED
TO CONNECT STANDARDIZED ACTUATORS TO A RANGER BODY ASSEMBLY)

Body Size	Use ISO Flange Type
1", 1-1/2", 2"	F-07
3", 4", 6"	F10
8" LF	F10
8"HF	F12, F14

The contents of this publication are presented for informational purposes only, and while every effort has been made to ensure their accuracy, they are not to be construed as warranties or guarantees, express or implied, regarding the products or services described herein or their use or applicability. We reserve the right to modify or improve the designs or specifications of such product at any time without notice. Cashco, Inc. does not assume responsibility for the selection, use or maintenance of any product. Responsibility for proper selection, use and maintenance of any Cashco, Inc. product remains solely with the purchaser.

RANGER PRODUCT CODER

02/07/20

An "X" in POS 12 followed by a 5-digit control number overrides remaining selections.

RS POS 3 — POS 5 POS 6 **07** — POS 10 POS 11 POS 12 POS 13 POS 14 POS 15 POS 16 POS 17 **B**

POSITION 3 - SIZE/MATERIAL					
Size	DI *	CS	SST	H-C	
CODE					
1"	1	A	K	9	
1-1/2"	2	B	L	J	
2"	3	C	M	U	
3"	4	D	N	V	
4"	5	E	P	W	
6"	6	F	R	Y	
8" LF **	7	G	S	&	
8" HF **	NA	H	T	Z	

* Ductile Iron All Sizes Flangeless Only
 ** CS, SST, H-C Flanged Only
 NA = Not Available

POSITION 5 - BODY DESIGN, END CONNS., PRESSURE CLASS					
Press. Class	"Flangeless" Line Bolting			Flanged Body ² Front Flange Only	
	None	Opt-7A Alloy Steel	Opt-7C S.H. SST ¹	Std UNC Threaded Flg Holes	Metric Threaded Flg Holes
				CODE	
150#	0	1	4	A**	L**
300#	0	2	5	B**	M**
600#	0 ✓	3 ✓	6 ✓	C*	N*
PN40 †	E	NA	NA	NA	NA

¹ S.H. = Strain-Hardened, use when temperatures below -20° F.
² Flange bolting not available for integral flanged units.
 * 1", 1-1/2", 2" & 3" body sizes only.
 ** 8" size - CS, SST, H-C bodies only, are Not available "Flangeless"
 All sizes - DI is only available in flangeless design 150# & 300# Pressure Class.
 ✓ 6" Size Flangeless not available.
 † 3", 4", 6" & 8" Sizes not available

POSITION 6 - TRIM & PACKING										
Pack- ing	CODE									
	ST1	ST2	ST6	ST7	ST8*	CT1**	CT2**	HT1	HT2	HT7
Std	1	2	3	4	7	5	6	R	S	T
-38V	A	B	C	D	G	E	F			
-38HT	J	K	L	M	U	N	P			

* Includes Opt-18 SLURRY/ABRASION Trim - Select Reverse Flow in Position 16.
 ** Suitable for Opt-40 NACE; Select codes A or B in Position 17

POSITION 11 - ACTUATOR MOUNTING POSITION					
Actuator Model	Actuator Action	Mtg. Pos.	HORIZ CODE	Mtg. Pos.	VERT CODE
48 & 148	ATO/FC	A	A	E	E
	ATC/FO	B	B	F	F
	ATO/FC	C	C	G	G
	ATC/FO	D	D	H	H
RC for 8" HF	(For HIGH TEMPERATURE applications select Opt-38HT code from Position 6)				
0-100 psid	ATO/FC	A	P	E	V
	ATC/FO	B	Q	F	W
101-200 psid	ATO/FC	A	R	E	Y
	ATC/FO	B	S	F	Z
201-325 psid	ATO/FC	A	T	E	\$
	ATC/FO	B	U	F	&
Body Assy Only **	Cashco Act. w/ yoke	J			
	Short Stem Assy w/ yoke	K*			
	ISO 5211 Act. Mount w/yoke	M*			
	Cashco Act. w/o yoke	L			

* 8" HF is limited to these selections.
 ** Use code "0" in Positions 12 thru 15 and Use code "8" or "9" in Position 16.
 ATC-FO must have handwheel, select codes "0" or "1" in Position 16.

POSITION 10 - TRIM Accs. - Std or Reverse Flow except for AC1 & AC2								
Backend Low Noise Insert	Seal Retainers							
	CODE							
	Std.	0.6 0.5*	0.4 0.3*	0.2	Reverse *** Flow Only AC1 AC2	LNA	LNB	
None	0	1	2	3	4	5	6	7
Abr. Sleeve **	A	B	C	D	E	F		
LN2 1 1/2" - 8"	J	K	L	M			R	S
LN3 3" - 8"	T	V	W	Y			#	\$
LN4 4" - 8"	Q	^	&	<			8	?

* 8HF Only.
 ** Not available for 1" body size.
 *** Select codes 1 or 8 on Position 16.

POSITION 12 - 764P* (Bracket Mounted) - ADDITIONAL AIRSET* (Bracket Mounted) - Solenoid Valves			
764P Action	Solenoid Valve *** Exhaust on Deenergization		
	CODE		
	None	120VAC 60 Hz	24 VDC
None	0	6	C
Reverse **	2	8	E
Reverse W/ Airset **	3	9	F
Direct **	4	A	G
Direct W/ Airset **	5	B	H
For Special Construction Contact Cashco for Special Code	X		

* Refer to 764-TB for Product Code of Controller.
 ** Select Codes 4 or 1 on Position 13 if positioner is needed.
 ***Solenoid rated as 4/4X only.

POSITION 13 - DIRECT ACTING POSITIONER with AIRSET (Bracket Mounted) (3-15 psig) 4-20 mA SST Tubing					
Specify Split Range in Special Instructions on the P.O. and Order Entry Screen					
Positioner Model	Ratings	Analog/Digital	Hart	Fieldbus	Profibus
CODE					
73 P/P *	Gen. Purpose	4			
P5 P/P	Gen. Purpose	1			
D20 D I/P	Gen. Purpose	C	D		
D20 I I/P	Intrinsically Safe	2	5		
D20 E I/P ***	Explosion Proof	E	F		
D3 X I/P	Gen. Purpose	L	M	N	P
D3 I I/P	Intrinsically Safe	3	6	8	A
D3 E I/P ****	Explosion Proof	G	H	J	K
PS2-1 I/P	Gen. Purpose		R	S	T
PS2-2 I/P	Intrinsically Safe		7	9	B
PS2-3 I/P ***	Explosion Proof		U	V	W
None		0			
None **		#			

* Includes gauge port and gauge, select 5 or 6 from Position 14. Model 73 not available on 8"HF.
 ** Includes Mounting Hardware to IEC 60534-6-2 (Namur) Mounting Dims.
 *** Not available with limit/proximity switch option. Select codes "8", "9" or "0" in Pos. 15.
 **** Not available with options. Please select code "0" in Pos. 15.

POSITION 14 - VALVE CHARACTERISTIC / GAUGE BLOCK				
Inherent Valve Characteristic is Linear	Positioner			
	NO Positioner selected	Without Gauge Block	With Gauge Block **	With Gauge Ports *
	CODE			
Linear	0	1	2	5
Equal %		3	4	6

* Model 73 P/P includes gauge port and gauge.
 * For P5 gauge ports built in. No gauges.
 * For D20 E, D3 E & PS2-3 gauge ports built-in. No gauges
 ** For D20 D & D20 I and PS2-1 & PS2-2 - gauge block with gauges.
 ** For D3 X & D3 I gauge block only - no gauges.

POSITION 15 - POSITIONER OPTIONS						
Options	POSITIONERS			I/P TRANSDUCERS		
	Inductive Limit Switches	Micro-switches Limit Switches	Position Transmitter	3-15 PSIG No Airset	3-15 PSIG W/ Airset	6-30 PSIG No Airset
	6-30 PSIG W/ Airset	By Pass Valve	CODE			
73				A	D	N
P5				4	5	
D3 & D20	7	T	9			
PS2			8			
No Positioner				C	F	J
None				0		

POSITION 16 - OPTIONS		
***	Standard Flow Direction	Reverse Flow Direction
Std/Handwheel	0	1
No Handwheel	9	8

*** 8"HF Standard is without Handwheel.
 If ATC-FO, codes "0" or "1" must be selected.

POSITION 17 - PAINTING/CLEANING/SERVICE					
Painting	Opt.	Standard Cleaning	Clean to Opt-56 Spec. #S-1542	Clean to Opt-55 Spec. #S-1134 * (O ₂ Cleaned)	NACE Const.
CODE					
Standard	—	0	3	6	A

* SST bodies only. Cleaned for oxygen service/Required for Cryo Service.

*** For information on ATEX see
pages 23 & 24 on the IOM.**

Cashco, Inc.
P.O. Box 6
Ellsworth, KS 67439-0006
PH (785) 472-4461
Fax. # (785) 472-3539
www.cashco.com
email: sales@cashco.com
Printed in U.S.A. Ranger-TB

Cashco GmbH
Handwerkerstrasse 15
15366 Hoppegarten, Germany
PH +49 3342 30968 0
Fax. No. +49 3342 30968 29
www.cashco.com
email: germany@cashco.com

Cashco do Brasil, Ltda.
Al.Venus, 340
Indaiatuba - Sao Paulo, Brazil
PH +55 11 99677 7177
Fax. No.
www.cashco.com
email: brazil@cashco.com